



RAYSTAR



SPECIFICATION

OLED SPECIFICATION

Model No:

REX128128D-CTP

General Specification

The Features is described as follow:

- Module dimension: $\varnothing 50.5 \times 5.0$ mm
- Active area: $\varnothing 30.0$ mm
- Dot Matrix: 128*128
- Pixel size: 0.210 x 0.210 mm
- Pixel pitch: 0.235 x 0.235 mm
- Display Mode: Passive Matrix
- Duty: 1/128 Duty
- Gray Scale: 4 bits
- Display Color: Monochrome
- IC: SSD1327
- Interface: 4-line SPI , I2C
- SIZE:1.18 inch

- PCAP IC:IT7259
- Detect Point:1
- PCAP Interface:I2C
- PCAP Surface Hardness:6H

Interface Pin Function

No.	Symbol	Function						
1	VSS	Ground pin. It must be connected to external ground.						
2	VCC	Power supply for panel driving voltage. This is also the most positive power voltage supply pin. It is supplied by external high voltage source.						
3	VCOMH	COM signal deselected voltage level. A capacitor should be connected between this pin and VSS. No external power supply is allowed to connect to this pin.						
4	VCI	Low voltage power supply and power supply for interface logic level. It should match with the MCU interface voltage level and must be connected to external source. VCI must always set to be equivalent to or higher than VDD.						
5	VDD	Power supply pin for core logic operation.						
6	BS1	MCU bus interface selection pins. Select appropriate logic setting as described in the following table. BS1 is pin select. Bus Interface selection <table border="1" style="margin-left: 20px;"> <thead> <tr> <th>BS1</th> <th>Interface</th> </tr> </thead> <tbody> <tr> <td>0</td> <td>4-line SPI</td> </tr> <tr> <td>1</td> <td>I2C</td> </tr> </tbody> </table> <p>Note (1) 0 is connected to VSS (2) 1 is connected to VCI</p>	BS1	Interface	0	4-line SPI	1	I2C
BS1	Interface							
0	4-line SPI							
1	I2C							
7	IREF	This pin is the segment output current reference pin						
8	CS#	This pin is the chip select input connecting to the MCU. The chip is enabled for MCU communication only when CS# is pulled LOW (active LOW).						
9	RES#	This pin is reset signal input. When the pin is pulled LOW, initialization of the chip is executed. Keep this pin pull HIGH during normal operation.						
10	DC#	This pin is Data/Command control pin connecting to the MCU. When the pin is pulled HIGH, will be interpreted as data. When the pin is pulled LOW, will be transferred to a command register In I2C mode, this pin acts as SA0 for slave address selection.						
11	D0	When serial interface mode is selected, D0 will be the serial clock input:						
12	D1	SCLK; D1 will be the serial data input: SDIN and D2 should be kept NC.						
13	D2	When I2C mode is selected, D2, D1 should be tied together and serve as SDAout , SDAin in application and D0 is the serial clock input, SCL.						
14	TP_SCK	I2C clock signal						
15	TP_SDA	I2C data signal						
16	TP_INT	Interrupt signal						
17	VCC	Power supply for panel driving voltage. This is also the most positive power voltage supply pin.						
18	VSS	Ground						

Contour Drawing & Block Diagram

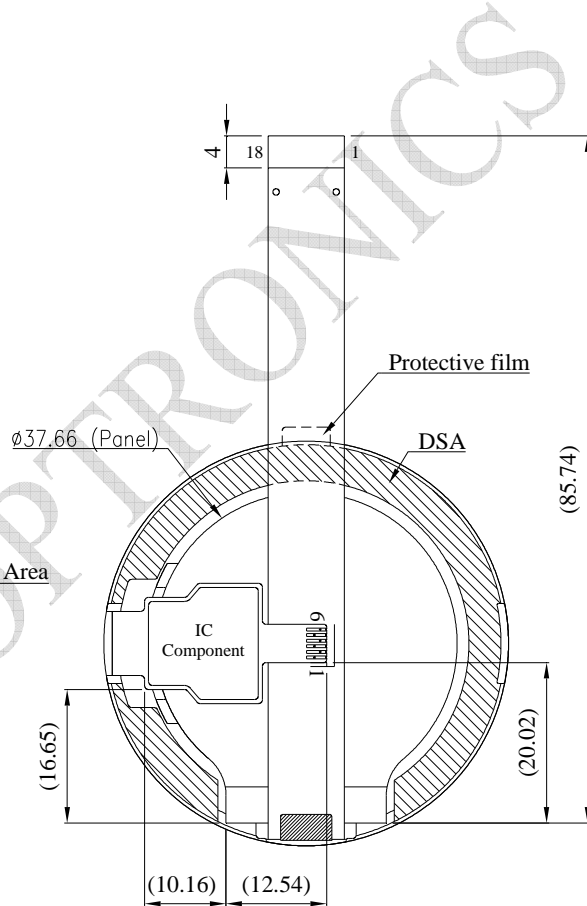
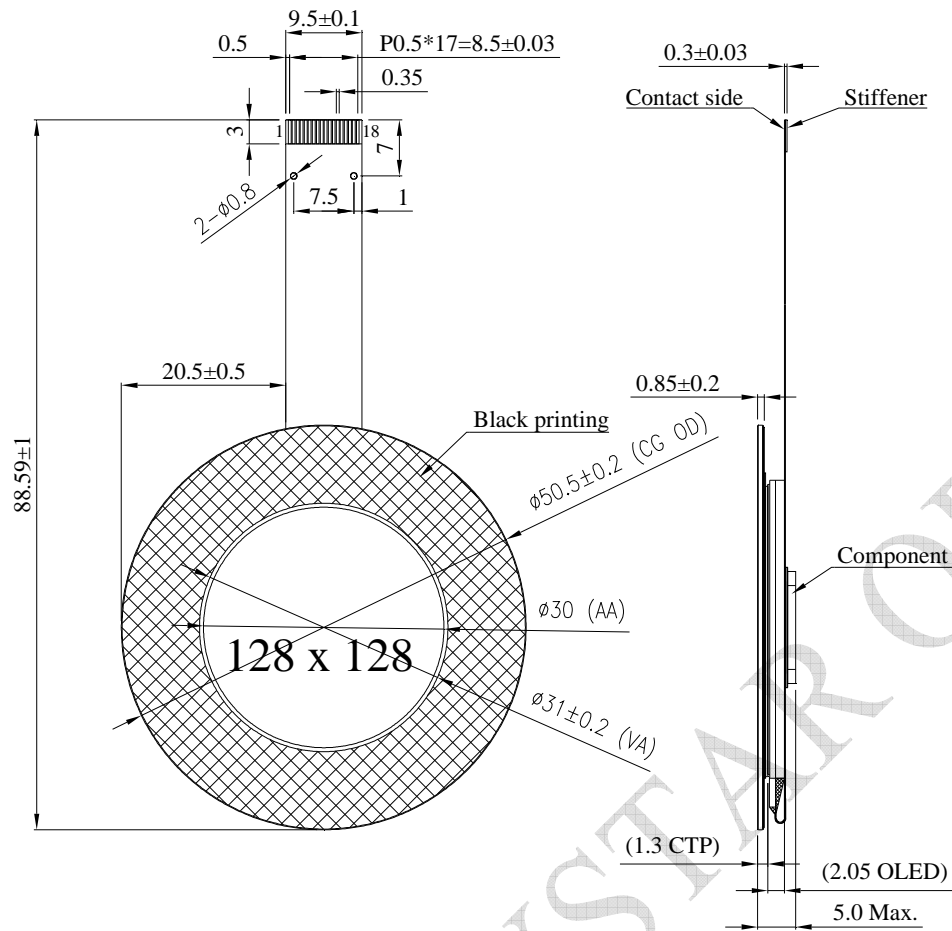

PIN	SYMBOL
1	VSS
2	VCC
3	VCOMH
4	VCI
5	VDD
6	BS1
7	IREF
8	CS#
9	RES#
10	D/C#
11	D0
12	D1
13	D2
14	TP_SCK
15	TP_SDA
16	TP_INT
17	VCC
18	VSS

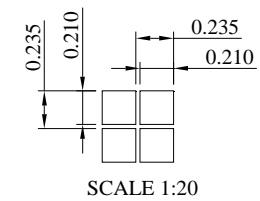

The non-specified tolerance of dimension is ±0.3 mm .

Absolute Maximum Ratings

Parameter	Symbol	Min	Max	Unit
Supply Voltage for Operation	VCI	-0.3	4.0	V
Supply Voltage for Logic	VDD	-0.5	2.75	V
Supply Voltage for Display	VCC	-0.5	19.0	V
Operating Temperature	TOP	-20	+50	°C
Storage Temperature	TSTG	-30	+70	°C

Electrical Characteristics

DC Electrical Characteristics

Item	Symbol	Condition	Min	Typ	Max	Unit
Supply Voltage for Logic	VCI	—	2.8	3.0	3.3	V
Supply Voltage for Display	VCC	—	14.0	14.5	15.0	V
High Level Input	VIH	—	0.8×VCI	—	VCI	V
Low Level Input	VIL	—	0	—	0.2×VCI	V
High Level Output	VOH	I _{out} = 100uA	0.9×VCI	—	VCI	V
Low Level Output	VOL	I _{out} = 100uA	0	—	0.1×VCI	V
50% Check Board operating Current		VCC = 14.5V	—	24	36	mA

Touch Panel Controller IT7259

Item	Symbol	Condition	Min	Typ	Max	Unit
Input High Volt.	VIH	COMS	1.2	—	—	V
Input Low Volt.	VIL	COMS	—	—	0.5	V
Output High Volt.	VOH	I _{OH} = 2mA	2.4	—	—	V
Output Low Volt.	VOL	I _{OL} = 2mA	—	—	0.4	V