

SDIO PRODUCT SPECIFICATION

**IEEE 802.11 b/g/n 2.4GHz 1T1R WiFi with Bluetooth
v2.1+EDR/Bluetooth 3.0/3.0+HS/4.0**

**RF-SM02B (Realtek RTL8723AS)
Combo Module**

Version 1.0

CONTENT

PRODUCT DESCRIPTION.....	3
PRODUCT FEATURES.....	3
PRODUCT SPECIFICATIONS.....	4
MAIN CHIPSET	4
FUNCTIONAL SPECIFICATIONS.....	4
MECHANICAL	7
BLOCK DIAGRAM.....	8
MODULE PIN ASSIGNMENT.....	10
ID SETTING INFORMATION.....	11
ENVIRONMENTAL.....	11
OPERATING	11
STORAGE.....	11
Circuit reference pictures.....	11
Module PIN feet definition figure.....	11
WIFI\BT RF Circuit reference pictures.....	11
SDIO interface Circuit reference pictures.....	12
BT interface Circuit reference pictures.....	12
Recommended Reflow Profile.....	13
MTBF CACULATION.....	14

PRODUCT DESCRIPTION

RF-SM02 is a small size and low profile of WiFi+BT combo module with LGA (Land-Grid Array) footprint, board size is 20mm*10mm with module height 2mm. It can be easily manufactured on SMT process and highly suitable for tablet PC, ultra book, mobile device and consumer product. It provides GSPI/SDIO interface for WiFi to connect with host processor and high speed UART interface for BT. It also has a PCM interface for audio data transmission with direct link to external audio codec via BT controller. The WiFi throughput can go up to 150Mbps in theory by using 1x1 802.11n b/g/n MIMO technology and Bluetooth can support BT2.1+EDR/BT3.0 and BT4.0.

RF-SM02 uses Realtek RTL8723AS, a highly integrated WiFi/BT single chip based on advanced COMS process. RTL8723AS almost integrates whole WiFi/BT function blocks into a chip, such as SDIO/UART, MAC, BB, AFE, RFE, PA, EEPROM and LDO/SWR, except fewer passive components remained on PCB.

PRODUCT FEATURES

- Operate at ISM frequency bands (2.4GHz)
- GSPI/SDIO for WiFi and UART for Bluetooth
- IEEE standards support: IEEE 802.11b, IEEE 802.11g, IEEE 802.11n, IEEE 802.11d, IEEE 802.11e, IEEE 802.11h, IEEE 802.11i
- Fully Qualified Bluetooth 2.1 + EDR specification including both 2Mbps and 3Mbps modulation mode
- Fully qualified Bluetooth 3.0
- Fully qualified Bluetooth 4.0 Dual mode
- Full –speed Bluetooth operation with Piconet and Scatternet support.
- Enterprise level security which can apply WPA/WPA2 certification for WiFi.
- WiFi 1 transmitter and 1 receiver allow data rates supporting up to 150 Mbps downstream and 150 Mbps upstream PHY rates
- Support sophisticated WiFi/BT coexistence mechanism to enhance collocation performance
- Support antenna diversity for WiFi and BT antenna selection
- Support Bluetooth adaptive power management mechanism
- Full-featured software utility for easy configuration and management
- RoHS compliance
- Low Halogen compliance

PRODUCT SPECIFICATIONS

Main chipset

WiFi/BT Single Chip: Realtek RTL8723AS-CG

Functional Specifications

Standards	<p>WiFi:</p> <p>IEEE 802.11b, IEEE 802.11g, Draft IEEE 802.11n, IEEE 802.11d, IEEE 802.11e, IEEE 802.11h, IEEE 802.11i</p> <p>BT:</p> <p>V2.1+EDR/BT v3.0/BT v3.0+HS/BT v4.0</p>
Bus Interface	<p>WiFi: GSPI/SDIO BT: UART</p>
Form Factor	L*W*H = 20mm*10mm*2mm
Data Rate	<p>802.11b:</p> <p>11, 5.5, 2, 1 Mbps</p> <p>802.11g: 54, 48, 36, 24, 18, 12, 9, 6 Mbps</p> <p>802.11n:</p> <p>MCS 0 to 7 for HT20MHz</p> <p>MCS 0 to 7 for HT40MHz</p> <p>BT:</p> <p>1 Mbps for Basic Rate 2,3 Mbps for Enhanced Data Rate</p>
Media Access Control	<p>WiFi:</p> <p>CSMA/CA with ACK BT:</p> <p>AFH, Time Division</p>
Modulation Techniques	<p>802.11b:</p> <p>CCK, DQPSK, DBPSK</p> <p>802.11g: 64 QAM, 16 QAM, QPSK, BPSK 802.11n:</p> <p>64 QAM, 16 QAM, QPSK, BPSK</p> <p>BT:</p> <p>8DPSK, $\pi/4$ DQPSK, GFSK</p>
Network Architecture	<p>WiFi:</p>

	Ad-hoc mode (Peer-to-Peer) Infrastructure mode BT: Pico Net Scatter Net		
Operating Channel	WiFi 2.4GHz: 11: (Ch. 1-11) – United States 13: (Ch. 1-13) – Europe 14: (Ch. 1-14) – Japan BT 2.4GHz: Ch. 0 ~78		
Frequency Range	2.400GHz ~ 2.4835 GHz		
Transmit Output Power – 1x1 (Tolerance: ±1.5dBm)	802.11b@11Mbps 16dBm	802.11g@6Mbps 16dBm	802.11n 16dBm (MCS 0_HT20)
		802.11g@54Mbps 14dBm	13dBm (MCS 7_HT20) 13dBm (MCS 0_HT40) 13dBm (MCS 7_HT40)
	BT: Max +10dBm		
Receiver Sensitivity	802.11b@11Mbps -84dBm	802.11g@54Mbps -73dBm	802.11n -69dBm (MCS 7_HT20)
			-66dBm (MCS 7_HT40)
	BT: -89dBm@1Mbps, -90dBm@2Mbps, -83dBm@3Mbps		
Security	WiFi : WPA, WPA-PSK, WPA2, WPA2-PSK, WEP 64bit & 128bit, IEEE 802.11x, IEEE 802.11i BT: Simple Paring		
Operating Voltage	3.3 V ±9% I/O supply voltage		
OS supported	Windows XP/Win7/Linux/Android		

<p>Power Consumption (3.3V) (Typical)</p>	<p>WiFi : TX Mode: (Conituous mode) 260mA (MCS7/BW40/13dBm)</p> <p>RX Mode: (Conituous mode) 190mA (MCS7/BW40/-60dBm)</p> <p>Associated Idle: 4mA</p> <p>Unassociated Idle: 2.9mA</p> <p>RF disable Mode: 3mA</p> <p>BT : Inquiry & Page Scan: 1.7mA</p> <p>ACL no traffic: 15mA</p> <p>SCO HV3: 20mA</p> <p>Parked 1.28s beacon: 1.12mA</p> <p>Reset: 0.05mA</p>
--	---

Mechanical

Dimensions (mm)	Length	Width	Height
	22.25 (Tolerance:±0.2mm)	11.745 (Tolerance:±0.2mm)	1.7 (Tolerance:±0.2mm)

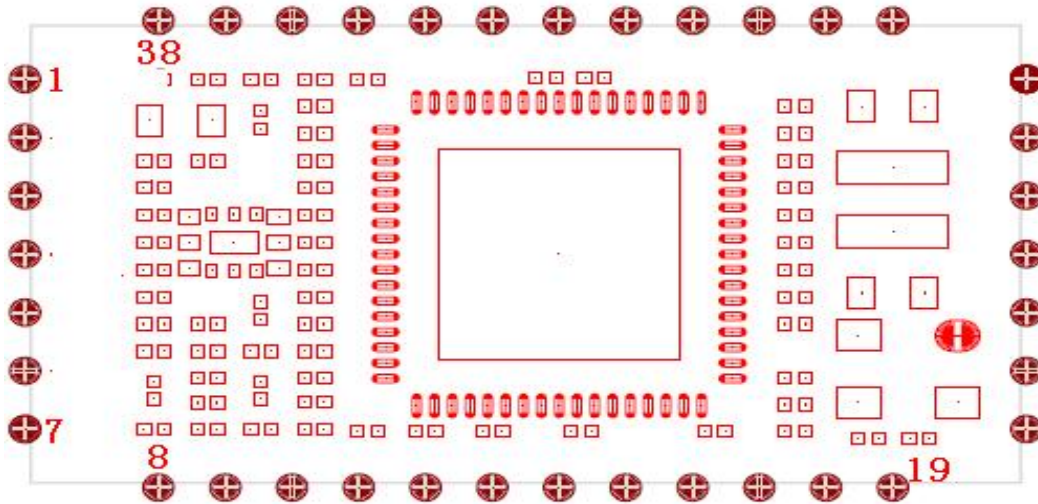

Fig.1 Top Layer (Top View)

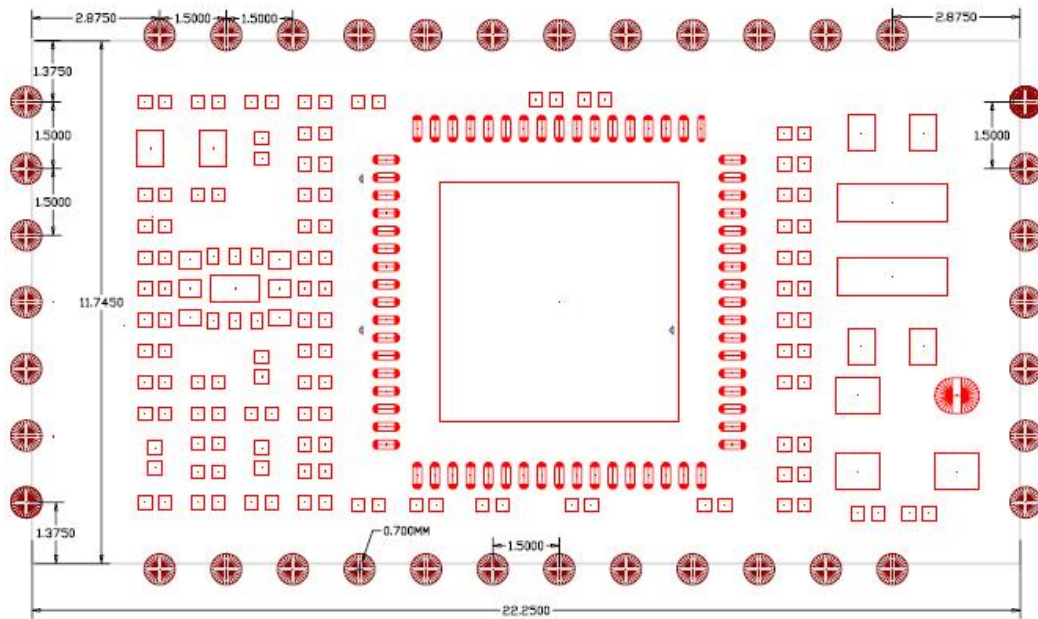

Fig.2 Size chart (Top View)

Block Diagram

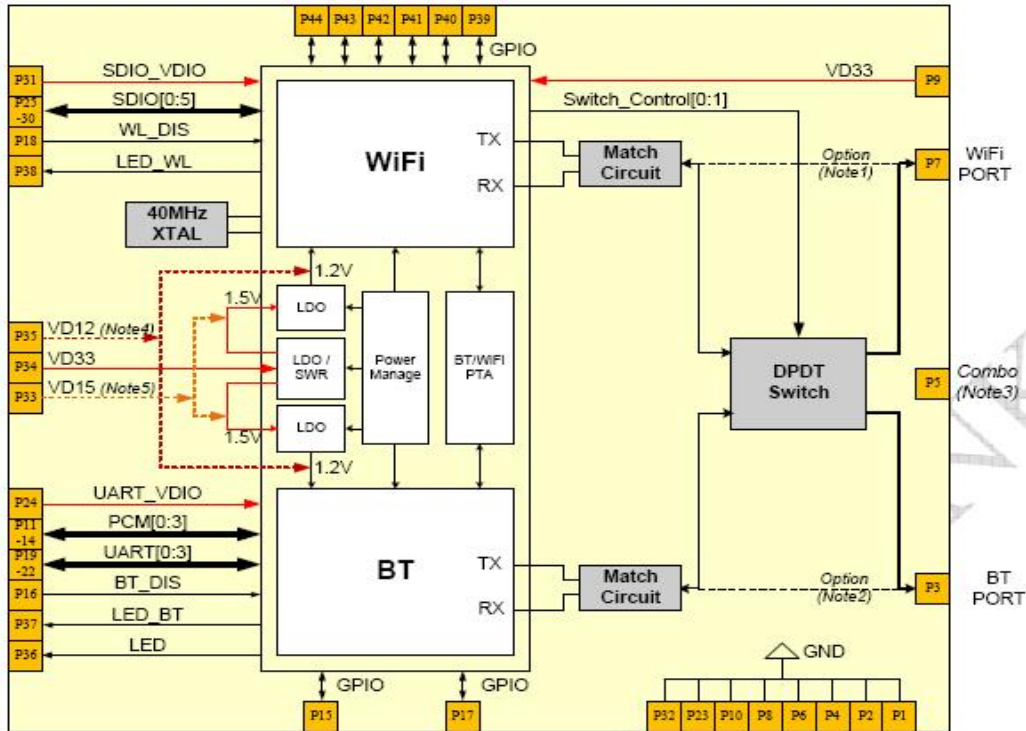

Fig.3 Block Diagram with Dual RF Port

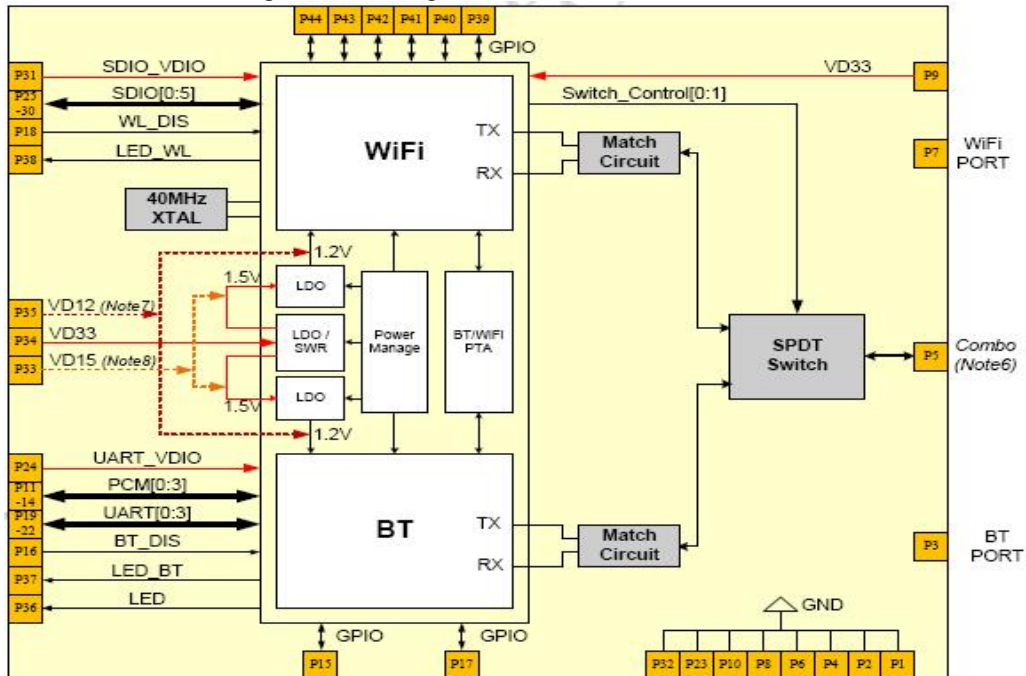

Fig.4 Block Diagram with Single RF Port

(2) This module also reserves flexibility to support separate WiFi/BT RF fixed path without DPDT.

Note3,6:

(1) Option for single antenna. WiFi/BT shares the single RF port and a SPDT required for switching between BT and WiFi.

Note4,5,6,7:

(1) Default this module only require 3.3V single power source and core voltage generated by internal voltage regulator.

(2) This module reserves flexibility for external power source if system can provide VD12/VD15 for this module

MODULE PIN ASSIGNMENT

Pin	Function	Pin	Function
1	GND	20	UART_VDIO VDD for UART Pin, the power supply is same as the signal level of UART bus (3.3V ~ 1.8V)
2	BT_RF	21	SD_D1
3	GND	22	SD_D0
4	COMBO_RF	23	SD_CLK
5	GND	24	SD_CMD
6	WL_RF	25	SD_D3/USB_D+
7	GND	26	GND
8	GND	27	SD_D2/USB_D-
9	BT_PCM_CLK General Purpose Input/Output Pin	28	SD_VDIO VDD for SDIO Pin, the power supply is same as the signal level of SDIO bus (3.3V ~ 1.8V)
10	BT_PCM_SYNC	29	VD33
11	BT_PCM_OUT Trap function: weak pull low to enable integrated switching regulator; weak pull high to enable integrated linear regulator . General Purpose Input/Output Pin	30	LED LED Pins (Active Low)
12	BT_PCM_IN Trap function: weak pull low to enable RTL8723 to enter normal operation mode. General Purpose Input/Output Pin	31	LED_BT
13	GPIO(12)/WPS This pin is for WIFI function to wakeup host when remote wake function is enabled. The Polarity can be defined by customer.	32	LED_WL
14	GPIO(11)/BT_DIS This Pin Can Externally Shutdown the RTL8723AS (no requirement for Extra Power Switch) when WL_DISn is pulled low This pin can also support the BT Radio-off function with host interface remaining connected.	33	GND
15	GPIO(11)/WL_DIS This Pin Can Externally Shutdown the RTL8723AS (no requirement for Extra Power Switch) when BT_DISn is pulled low This pin can also support the WLAN Radio-off function with host interface remaining connected.	34	GND

16	UART_IN High-Speed UART Data In	35	GND
17	UART_RTS High-Speed UART RTS	36	GND
18	UART_CTS High-Speed UART CTS	37	EESK
19	UART_OUT High-Speed UART Data Out	38	GND

Module PIN feet definition figure

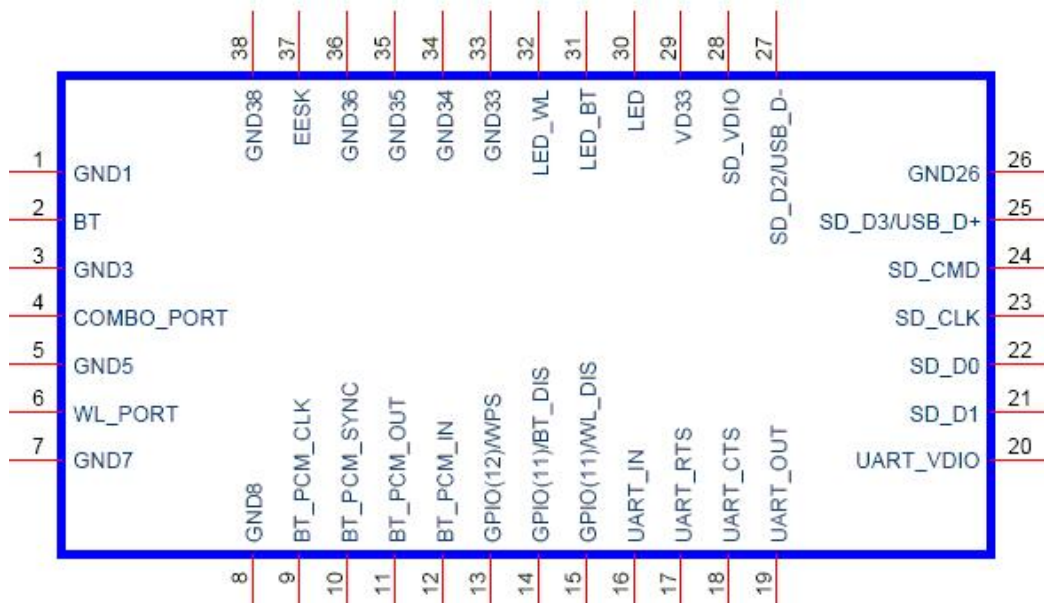

WIFI/BT RF Circuit reference pictures

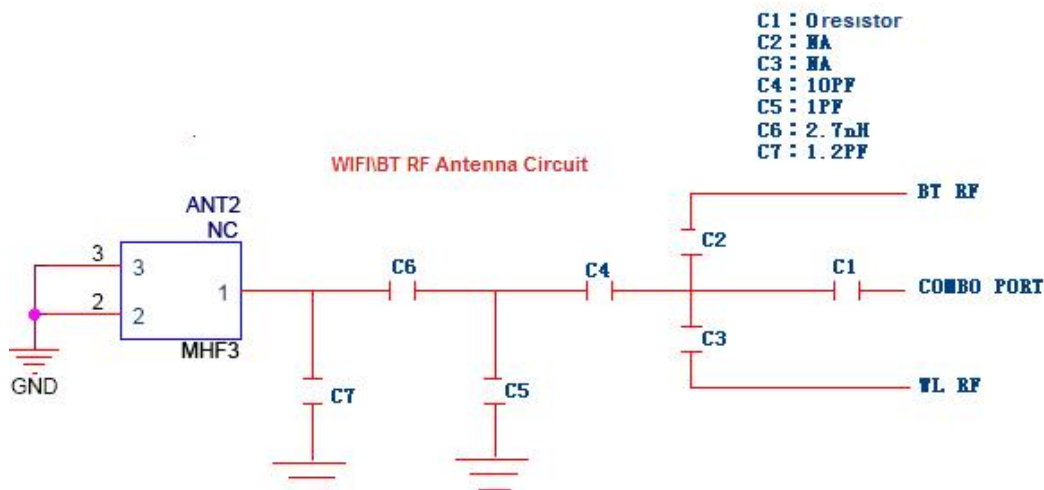

Note: The above RF traces are 50 ohm impedance, the alignment can not go 90 degrees, the alignment can not be longer than 15MM.

SDIO interface Circuit reference pictures

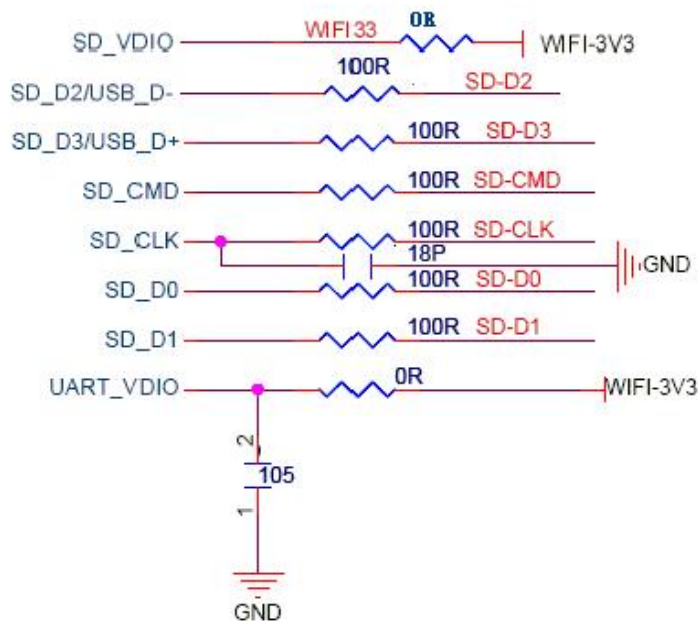

BT interface Circuit reference pictures

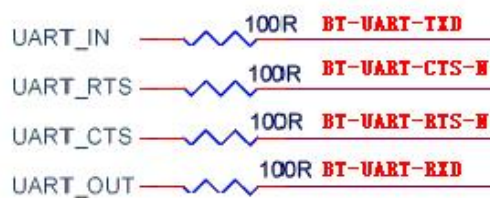

Recommended Reflow Profile

Referred to IPC/JEDEC standard.

Peak Temperature : $<250^{\circ}\text{C}$

Number of Times : ≤ 2 times

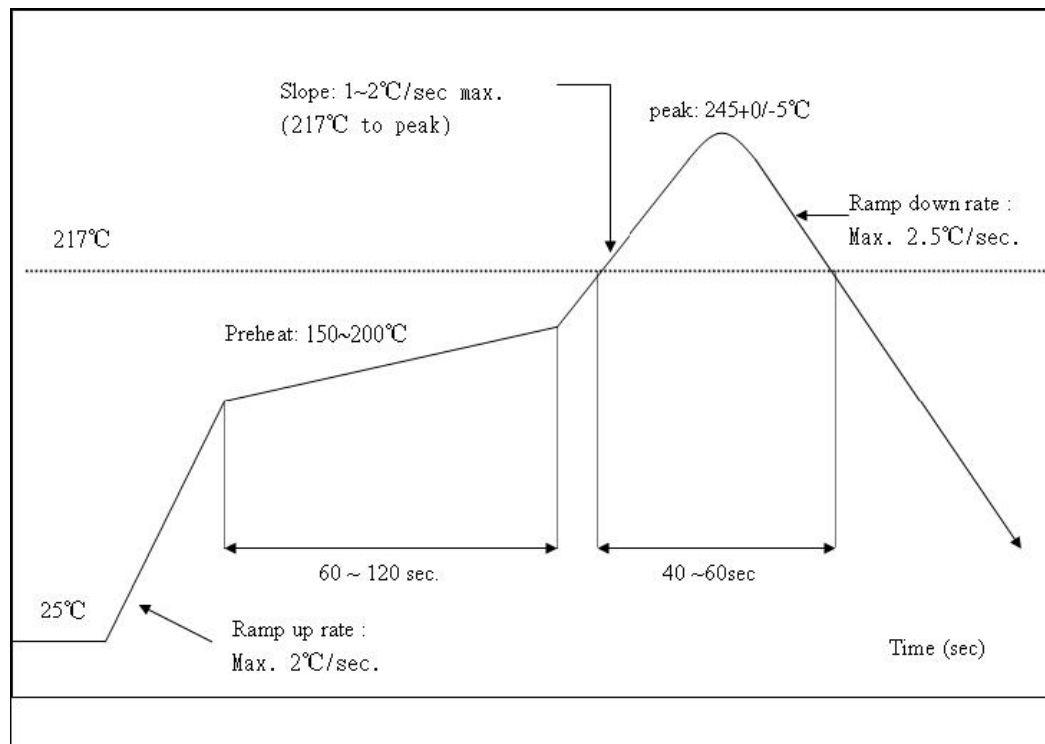

ID SETTING INFORMATION

Reg Domain	World Wide 13 Channels 1-11 with active scan Channels 12,13 with passive scan Channel 14 with no scan
Reg Domain Code	0x0A
Vendor ID	WiFi : 0x10EC BT : 0x0BDA
Device ID	WiFi : 0x8723 BT : 0x8723 (PID)
Subsystem Device ID	0x8723 (Realtek demoboard)
Subsystem Vendor ID	0x10EC

ENVIRONMENTAL**Operating**

Operating Temperature: 0°C to +70 °C
Relative Humidity: 5-90% (non-condensing)

Storage

Temperature: -40°C to +80°C (non-operating)
Relevant Humidity: 5-95% (non-condensing)

MTBF caculation

Over 150,000hours