



HITANO ENTERPRISE CORP.

7F-7, No. 3, Wu Chuan 1st Road, New Taipei Industrial Park, New Taipei City, Taiwan, R.O.C.
Tel. : 886-2-22991331 Fax : 886-2-22982466

SPECIFICATION FOR

Ultra High-Q and Low ESR MULTILAYER CERAMIC CHIP

CAPACITORS

Series : RF Series

Description : Ultra Hi-Q & Low ESR MULTILAYER CERAMIC CHIP
CAP.

Size 0201~0805, NPO , 25V to 250V

RoHS Compliant & Halogen Free

<u>DRAWN BY</u>	<u>CHECKED BY</u>	<u>APPROVED BY</u>
蕭敏珍	蔡永承	巫宏俊

1. INTRODUCTION

MLCC consists of a conducting material and electrodes. To manufacture a chip-type SMT and achieve miniaturization, high density and high efficiency, ceramic condensers are used.

Hitano RF series MLCC is used at high frequencies generally have a small temperature coefficient of capacitance, typical within the $\pm 30\text{ppm}/^\circ\text{C}$ required for NP0 (COG) classification and have excellent conductivity internal electrode. Thus, our RF series MLCC will be with the feature of low ESR and high Q characteristics.

2. FEATURES

- High Q and low ESR performance at high frequency.
- Ultra low capacitance to 0.1pF.
- Can offer high precision tolerance to $\pm 0.05\text{pF}$.
- Quality improvement of telephone calls for low power loss and better performance.
- RoHS compliant
- HALOGEN compliant

3. APPLICATIONS

- Telecommunication products & equipments: Mobile phone, WLAN, Base station.
- RF module: Power amplifier, VCO.
- Tuners.

4. HOW TO ORDER

<u>RF</u>	<u>0603</u>	<u>N</u>	<u>100</u>	<u>J</u>	<u>500</u>	<u>C</u>	<u>T</u>
<u>Series</u>	<u>Size</u>	<u>Dielectric</u>	<u>Capacitance</u>	<u>Tolerance</u>	<u>Rated voltage</u>	<u>Termination</u>	<u>Packaging</u>
RF=Ultra High Q & Low ESR	0201 (0603) 0402 (1005) 0603 (1608) 0805 (2012)	N=NP0 (COG)	Two significant digits followed by no. of zeros. And R is in place of decimal point. eg.: 0R5=0.5pF 1R0=1.0pF 100= 10×10^0 =10pF	A= $\pm 0.05\text{pF}$ B= $\pm 0.1\text{pF}$ C= $\pm 0.25\text{pF}$ D= $\pm 0.5\text{pF}$ F= $\pm 1\%$ G= $\pm 2\%$ J= $\pm 5\%$	Two significant digits followed by no. of zeros. And R is in place of decimal point. 6R3=6.3 VDC 100=10 VDC 250=25 VDC 500=50 VDC 101=100 VDC 251=250 VDC	C=Cu/Ni/Sn	T=7" reeled G= 13" reeled

5. EXTERNAL DIMENSIONS

Size Inch (mm)	L (mm)	W (mm)	T (mm)/Symbol	Remark	M _B (mm)
0201 (0603)	0.60±0.03	0.30±0.03	0.30±0.03	L #	0.15±0.05
0402 (1005)	1.00±0.05	0.50±0.05	0.50±0.05	N #	0.25+0.05/-0.10
0603 (1608)	1.60±0.10	0.80±0.10	0.80±0.07	S	0.40±0.15
0805 (2012)	2.00±0.20	1.25±0.20	0.85±0.10	T	0.50±0.20

Reflow soldering only is recommended.

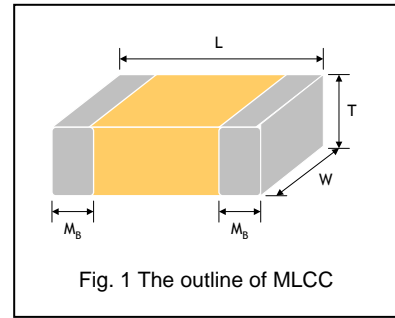

6. GENERAL ELECTRICAL DATA

Dielectric	NP0
Size	0201, 0402, 0603, 0805
Capacitance*	0201: 0.1pF to 33pF; 0402: 0.1pF to 22pF; 0603: 0.3pF to 47pF; 0805: 0.3pF to 100pF
Capacitance tolerance	Cap≤5pF: A (±0.05pF), B (±0.1pF), C (±0.25pF) 5pF<Cap<10pF: B (±0.1pF), C (±0.25pF), D (±0.5pF) Cap≥10pF: F (±1%), G (±2%), J (±5%)
Rated voltage (WVDC)	6.3V, 10V, 25V, 50V, 100V, 250V
Q*	Cap≥30pF, Q≥1000; Cap<30pF, Q≥400+20C
Insulation resistance at U _r	≥10GΩ
Operating temperature	-55 to +125°C
Capacitance change	±30ppm/°C
Termination	Ni/Sn (lead-free termination)

* Measured at the conditions of 25°C ambient temperature and 30~70% related humidity.

Apply 1.0±0.2Vrms, 1.0MHz±10% for Cap≤1000pF and 1.0±0.2Vrms, 1.0kHz±10% for Cap>1000pF.

7. CAPACITANCE RANGE

DIELECTRIC		NPO											
SIZE		0201			0402		0603			0805			Tolerance
RATED VOLTAGE (VDC)		6.3	10	25	50	100	50	100	250	50	100	250	
Capacitance	0.1pF (0R1)	L	L	L	N	N							B
	0.2pF (0R2)	L	L	L	N	N							A, B
	0.3pF (0R3)	L	L	L	N	N	S	S	S	T	T	T	A, B
	0.4pF (0R4)	L	L	L	N	N	S	S	S	T	T	T	A, B
	0.5pF (0R5)	L	L	L	N	N	S	S	S	T	T	T	A, B, C
	0.6pF (0R6)	L	L	L	N	N	S	S	S	T	T	T	A, B, C
	0.7pF (0R7)	L	L	L	N	N	S	S	S	T	T	T	A, B, C
	0.8pF (0R8)	L	L	L	N	N	S	S	S	T	T	T	A, B, C
	0.9pF (0R9)	L	L	L	N	N	S	S	S	T	T	T	A, B, C
	1.0pF (1R0)	L	L	L	N	N	S	S	S	T	T	T	A, B, C
	1.2pF (1R2)	L	L	L	N	N	S	S	S	T	T	T	A, B, C
	1.5pF (1R5)	L	L	L	N	N	S	S	S	T	T	T	A, B, C
	1.8pF (1R8)	L	L	L	N	N	S	S	S	T	T	T	A, B, C
	2.2pF (2R2)	L	L	L	N	N	S	S	S	T	T	T	A, B, C
	2.7pF (2R7)	L	L	L	N	N	S	S	S	T	T	T	A, B, C
	3.3pF (3R3)	L	L	L	N	N	S	S	S	T	T	T	A, B, C
	3.9pF (3R9)	L	L	L	N	N	S	S	S	T	T	T	A, B, C
	4.7pF (4R7)	L	L	L	N	N	S	S	S	T	T	T	A, B, C
	5.6pF (5R6)	L	L	L	N	N	S	S	S	T	T	T	B, C, D
	6.8pF (6R8)	L	L	L	N	N	S	S	S	T	T	T	B, C, D
	8.2pF (8R2)	L	L	L	N	N	S	S	S	T	T	T	B, C, D
	10pF (100)	L	L	L	N	N	S	S	S	T	T	T	F, G, J
	11pF (110)	L	L	L	N		S	S	S	T	T	T	F, G, J
	12pF (120)	L	L	L	N		S	S	S	T	T	T	F, G, J
	13pF (130)	L	L	L	N		S	S	S	T	T	T	F, G, J
	15pF (150)	L	L	L	N		S	S	S	T	T	T	F, G, J
	16pF (160)	L	L	L	N		S	S	S	T	T	T	F, G, J
	18pF (180)	L	L	L	N		S	S	S	T	T	T	F, G, J
	20pF (200)	L	L	L	N		S	S	S	T	T	T	F, G, J
	22pF (220)	L	L		N		S	S	S	T	T	T	F, G, J
24pF (240)	L	L				S	S	S	T	T	T	F, G, J	
27pF (270)	L	L				S	S	S	T	T	T	F, G, J	
30pF (300)	L	L				S	S	S	T	T	T	F, G, J	
33pF (330)	L	L				S	S	S	T	T	T	F, G, J	
36pF (360)						S	S	S	T	T	T	F, G, J	
39pF (390)						S	S	S	T	T	T	F, G, J	
43pF (430)						S	S	S	T	T	T	F, G, J	
47pF (470)						S	S	S	T	T	T	F, G, J	
56pF (560)									T	T	T	F, G, J	
68pF (680)									T	T	T	F, G, J	
82pF (820)									T	T	T	F, G, J	
100pF (101)									T	T	T	F, G, J	

1. The letter in cell is expressed the symbol of product thickness.
2. For more information about products with special capacitance or other data, please contact PDC local representative.

8. PACKAGING DIMENSION AND QUANTITY

Size	Thickness (mm)/Symbol		Paper tape	
			7" reel	13" reel
0201 (0603)	0.30±0.03	L	15k	70K
0402 (1005)	0.50±0.05	N	10k	50k
0603 (1608)	0.80±0.07	S	4K	10K
0805 (2012)	0.85±0.10	T	4k	15k

Unit: pieces

9. ELECTRICAL CHARACTERISTICS

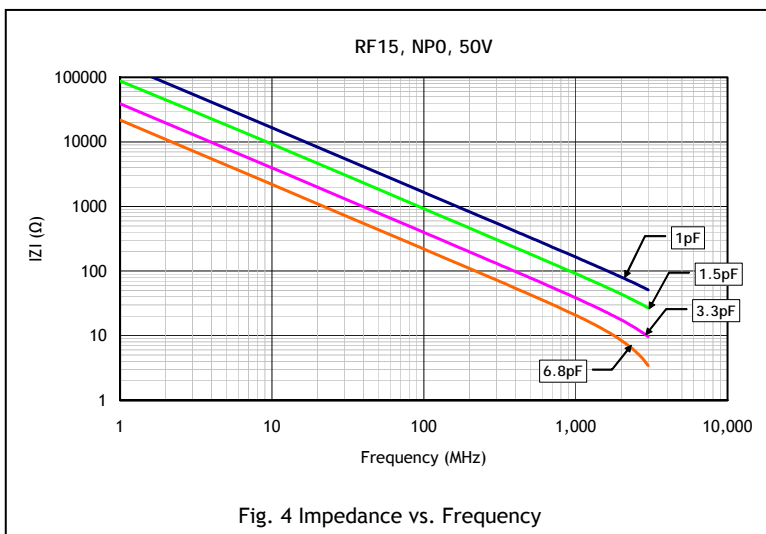
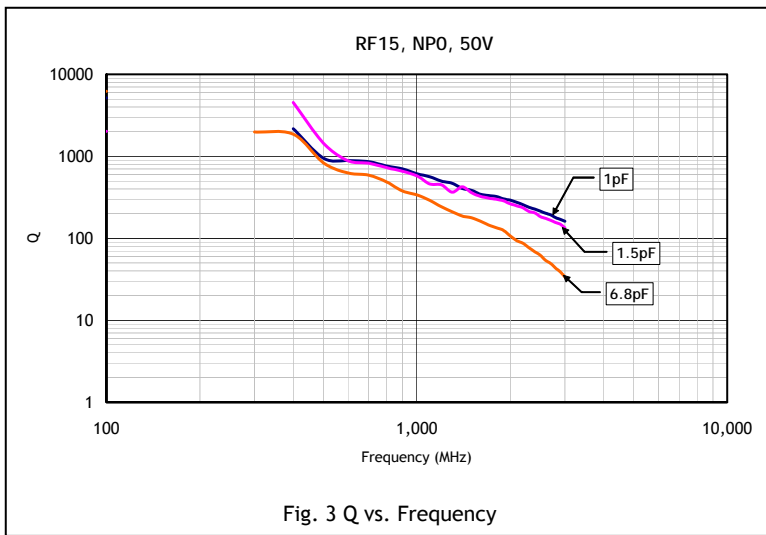
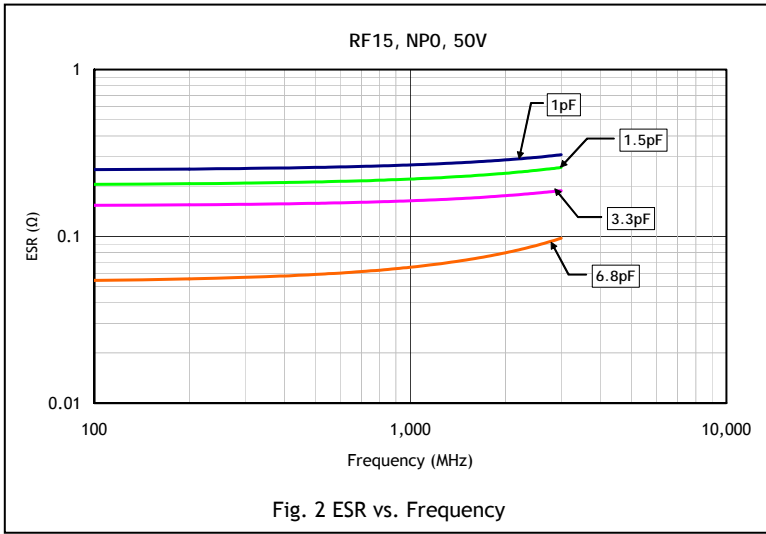

9. ELECTRICAL CHARACTERISTICS(Con.)

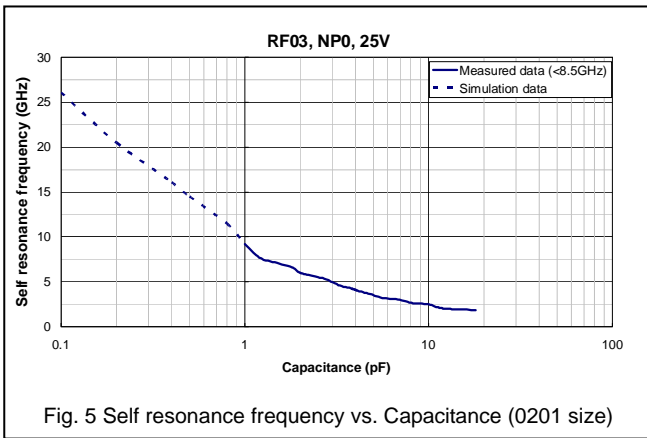

Fig. 5 Self resonance frequency vs. Capacitance (0201 size)

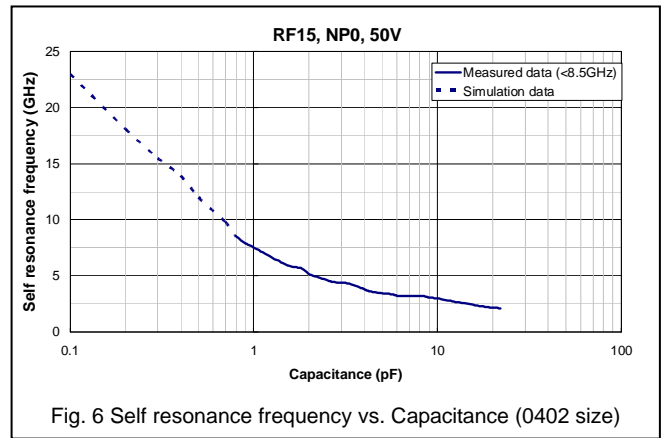

Fig. 6 Self resonance frequency vs. Capacitance (0402 size)

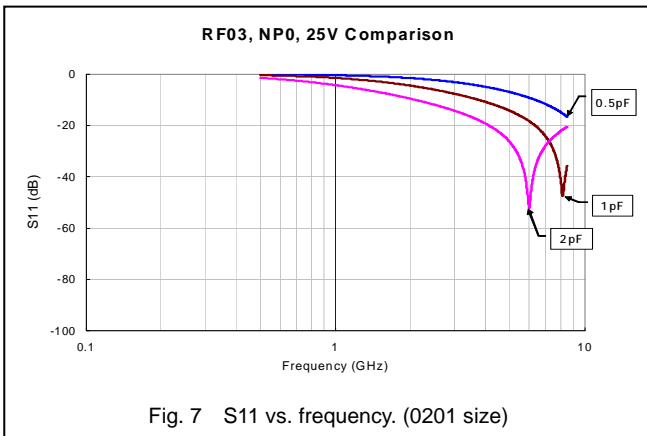

Fig. 7 S11 vs. frequency. (0201 size)

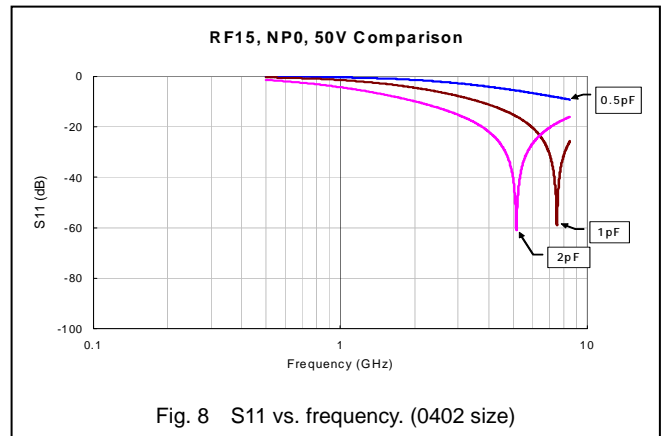

Fig. 8 S11 vs. frequency. (0402 size)

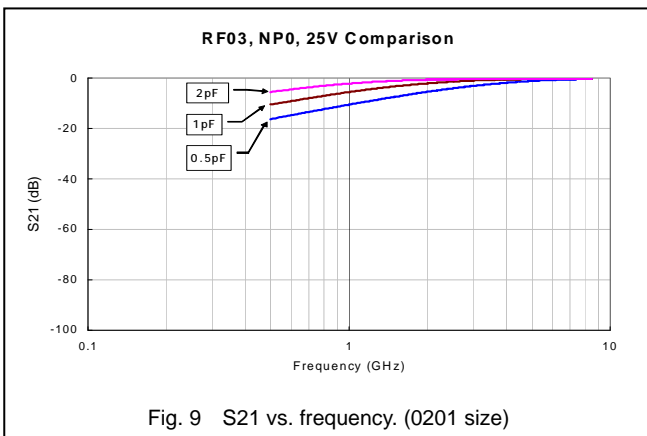

Fig. 9 S21 vs. frequency. (0201 size)

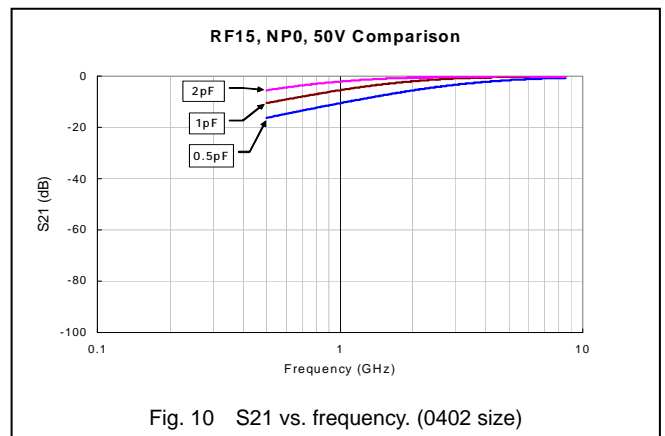

Fig. 10 S21 vs. frequency. (0402 size)

10. RELIABILITY TEST CONDITIONS AND REQUIREMENTS

No.	Item	Test Conditions	Requirements															
1.	Visual and Mechanical	---	<ul style="list-style-type: none"> * No remarkable defect. * Dimensions to conform to individual specification sheet. 															
2.	Capacitance	1.0±0.2Vrms, 1MHz±10%	<ul style="list-style-type: none"> * Shall not exceed the limits given in the detailed spec. 															
3.	Q/ D.F. (Dissipation Factor)	At 25°C ambient temperature.	<ul style="list-style-type: none"> * Cap≥30pF, Q≥1000; Cap<30pF, Q≥400+20C 															
4.	Dielectric Strength	<ul style="list-style-type: none"> * To apply voltage: ≤100V, ≥250% of rated voltage. 250V, ≥200% of rated voltage. * Duration: 1 to 5 sec. * Charge and discharge current less than 50mA. 	<ul style="list-style-type: none"> * No evidence of damage or flash over during test. 															
5.	Insulation Resistance	To apply rated voltage for max. 120 sec.	<ul style="list-style-type: none"> >10GΩ 															
6.	Temperature Coefficient	<ul style="list-style-type: none"> With no electrical load. Operating temperature: -55~125°C at 25°C 	<ul style="list-style-type: none"> * Capacitance change: within ±30ppm/°C 															
7.	Adhesive Strength of Termination	<ul style="list-style-type: none"> * Pressurizing force : 0201: 2N 0402 & 0603: 5N >0603: 10N * Test time: 10±1 sec. 	<ul style="list-style-type: none"> * No remarkable damage or removal of the terminations. 															
8.	Vibration Resistance	<ul style="list-style-type: none"> * Vibration frequency: 10~55 Hz/min. * Total amplitude: 1.5mm * Test time: 6 hrs. (Two hrs each in three mutually perpendicular directions.) 	<ul style="list-style-type: none"> * No remarkable damage. * Cap change and Q/D.F.: To meet initial spec. 															
9.	Solderability	<ul style="list-style-type: none"> * Solder temperature: 235±5°C * Dipping time: 2±0.5 sec. 	<ul style="list-style-type: none"> 95% min. coverage of all metalized area. 															
10.	Bending Test	<ul style="list-style-type: none"> * The middle part of substrate shall be pressurized by means of the pressurizing rod at a rate of about 1 mm per second until the deflection becomes 1 mm and then the pressure shall be maintained for 5±1 sec. * Measurement to be made after keeping at room temp. for 24±2 hrs. 	<ul style="list-style-type: none"> * No remarkable damage. * Cap change: within ±5.0% or ±0.5pF whichever is larger. (This capacitance change means the change of capacitance under specified flexure of substrate from the capacitance measured before the test.) 															
11.	Resistance to Soldering Heat	<ul style="list-style-type: none"> * Solder temperature: 270±5°C * Dipping time: 10±1 sec * Preheating: 120 to 150°C for 1 minute before immerse the capacitor in a eutectic solder. * Measurement to be made after keeping at room temp. for 24±2 hrs. 	<ul style="list-style-type: none"> * No remarkable damage. * Cap change: within ±2.5% or ±0.25pF whichever is larger. * Q/D.F., I.R. and dielectric strength: To meet initial requirements. * 25% max. leaching on each edge. 															
12.	Temperature Cycle	<ul style="list-style-type: none"> * Conduct the five cycles according to the temperatures and time. <table border="1"> <thead> <tr> <th>Step</th> <th>Temp. (°C)</th> <th>Time (min.)</th> </tr> </thead> <tbody> <tr> <td>1</td> <td>Min. operating temp. +0/-3</td> <td>30±3</td> </tr> <tr> <td>2</td> <td>Room temp.</td> <td>2~3</td> </tr> <tr> <td>3</td> <td>Max. operating temp. +3/-0</td> <td>30±3</td> </tr> <tr> <td>4</td> <td>Room temp.</td> <td>2~3</td> </tr> </tbody> </table> <ul style="list-style-type: none"> * Measurement to be made after keeping at room temp. for 24±2 hrs. 	Step	Temp. (°C)	Time (min.)	1	Min. operating temp. +0/-3	30±3	2	Room temp.	2~3	3	Max. operating temp. +3/-0	30±3	4	Room temp.	2~3	<ul style="list-style-type: none"> * No remarkable damage. * Cap change : within ±2.5% or ±0.25pF whichever is larger. * Q/D.F., I.R. and dielectric strength: To meet initial requirements.
Step	Temp. (°C)	Time (min.)																
1	Min. operating temp. +0/-3	30±3																
2	Room temp.	2~3																
3	Max. operating temp. +3/-0	30±3																
4	Room temp.	2~3																

10. RELIABILITY TEST CONDITIONS AND REQUIREMENTS

No.	Item	Test Condition	Requirements												
13.	Humidity (Damp Heat) Steady State	* Test temp.: 40±2°C * Humidity: 90~95% RH * Test time: 500+24/-0hrs. * Measurement to be made after keeping at room temp. for 24±2 hrs	* No remarkable damage. * Cap change: within ±5.0% or ±0.5pF whichever is larger. * Q/D.F. value: Cap≥30pF, Q≥350; 10pF≤Cap<30pF, Q≥275+2.5C Cap<10pF; Q≥200+10C * I.R.: ≥1GΩ.												
14.	Humidity (Damp Heat) Load	* Test temp.: 40±2°C * Humidity: 90~95%RH * Test time: 500+24/-0 hrs. * To apply voltage : rated voltage * Measurement to be made after keeping at room temp. for 24±2 hrs	* No remarkable damage. * Cap change: within ±7.5% or ±0.75pF whichever is larger. * Q/D.F. value: Cap≥30pF, Q≥200; Cap<30pF, Q≥100+10/3C * I.R.: ≥500MΩ.												
15.	High Temperature Load (Endurance)	* Test temp.: 125±3°C * To apply voltage: 200% of rated voltage. * Test time: 1000+24/-0 hrs. * Measurement to be made after keeping at room temp. for 24±2 hrs	* No remarkable damage. * Cap change: within ±3.0% or ±0.3pF whichever is larger. * Q/D.F. value: Cap≥30pF, Q≥350 10pF≤Cap<30pF, Q≥275+2.5C Cap<10pF, Q≥200+10C * I.R.: ≥1GΩ.												
16.	ESR	The ESR should be measured at room temperature and tested at frequency 1±0.1 GHz.	<table border="1"> <thead> <tr> <th></th> <th>0201, 0402</th> <th>0603</th> </tr> </thead> <tbody> <tr> <td>0.5pF≤Cap≤1pF: < 350mΩ</td> <td></td> <td>0.3pF≤Cap≤1pF: < 1500mΩ</td> </tr> <tr> <td>1pF<Cap≤5pF: < 300mΩ</td> <td></td> <td>1pF<Cap≤10pF: < 250mΩ</td> </tr> <tr> <td>5pF<Cap≤22pF: < 250mΩ</td> <td></td> <td>10pF<Cap≤47pF: < 200mΩ</td> </tr> </tbody> </table>		0201, 0402	0603	0.5pF≤Cap≤1pF: < 350mΩ		0.3pF≤Cap≤1pF: < 1500mΩ	1pF<Cap≤5pF: < 300mΩ		1pF<Cap≤10pF: < 250mΩ	5pF<Cap≤22pF: < 250mΩ		10pF<Cap≤47pF: < 200mΩ
	0201, 0402	0603													
0.5pF≤Cap≤1pF: < 350mΩ		0.3pF≤Cap≤1pF: < 1500mΩ													
1pF<Cap≤5pF: < 300mΩ		1pF<Cap≤10pF: < 250mΩ													
5pF<Cap≤22pF: < 250mΩ		10pF<Cap≤47pF: < 200mΩ													

11. APPENDIXES

■ Tape & reel dimensions

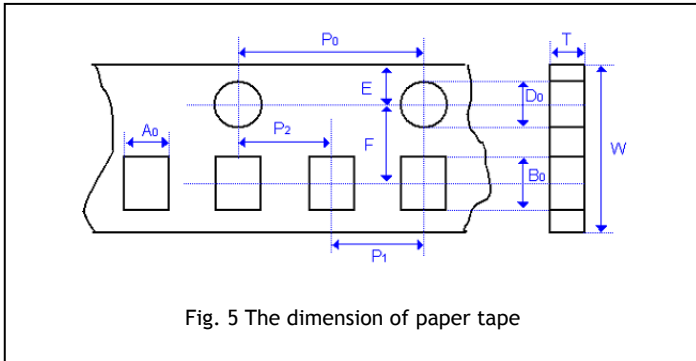

Size	0201	0402	0603	0805
Thickness	L	N	S	T
A₀	0.37±0.03	0.62±0.05	1.00 +0.05/-0.1	1.50±0.10
B₀	0.67±0.03	1.12±0.05	1.80±0.10	2.30±0.10
T	0.42±0.03	0.60±0.05	0.95±0.05	0.95±0.05
K₀	-	-	-	-
W	8.00±0.10	8.00±0.10	8.00±0.10	8.00±0.10
P₀	4.00±0.10	4.00±0.10	4.00±0.10	4.00±0.10
10xP₀	40.0±0.10	40.0±0.10	40.0±0.20	40.0±0.20
P₁	2.00±0.05	2.00±0.05	4.00±0.10	4.00±0.10
P₂	2.00±0.05	2.00±0.05	2.00±0.05	2.00±0.05
D₀	1.55±0.05	1.55±0.05	1.55±0.05	1.55±0.05
D₁	-	-	-	-
E	1.75±0.05	1.75±0.05	1.75±0.05	1.75±0.05
F	3.50±0.05	3.50±0.05	3.50±0.05	3.50±0.05

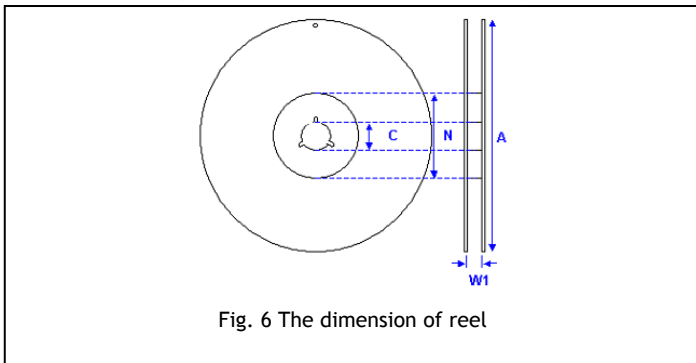

Size	0201, 0402, 0603, 0805	
Reel size	7"	13"
C	13.0+0.5/-0.2	13.0+0.5/-0.2
W₁	8.4+1.5/-0	8.4+1.5/-0
A	178.0±1.0	330.0±1.0
N	60.0+1.0/-0	100±1.0

▣ **Constructions**

No.	Name	NPO	
①	Ceramic material	BaTiO ₃ based	
②	Inner electrode	Cu	
③	Termination	Inner layer	Cu
④		Middle layer	Ni
⑤		Outer layer	Sn (Matt)

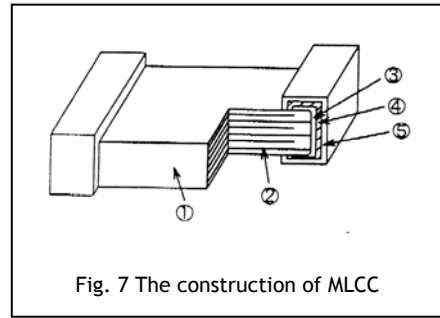

Fig. 7 The construction of MLCC

▣ **Storage and handling conditions**

- (1) To store products at 5 to 40°C ambient temperature and 20 to 70% related humidity conditions.
- (2) The product is recommended to be used within one year after shipment. Check solderability in case of shelf life extension is needed.

Cautions:

- a. Don't store products in a corrosive environment such as sulfide, chloride gas, or acid. It may cause oxidization of electrode, which easily be resulted in poor soldering.
- b. To store products on the shelf and avoid exposure to moisture.
- c. Don't expose products to excessive shock, vibration, direct sunlight and so on.

▣ **Recommended soldering conditions**

The lead-free termination MLCCs are not only to be used on SMT against lead-free solder paste, but also suitable against lead-containing solder paste. If the optimized solder joint is requested, increasing soldering time, temperature and concentration of N₂ within oven are recommended.

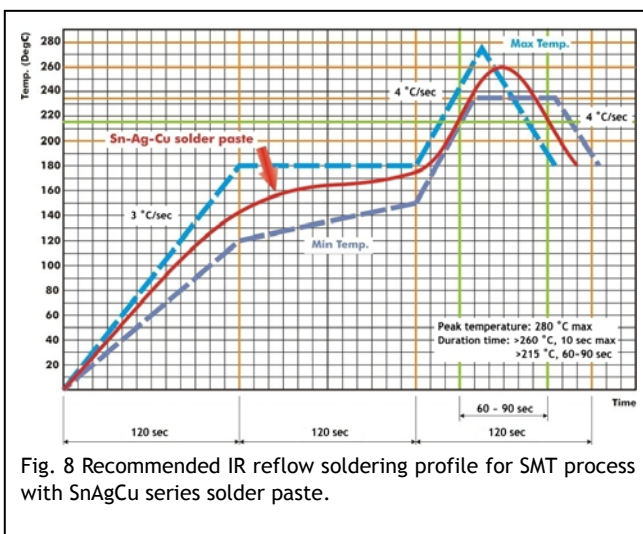

Fig. 8 Recommended IR reflow soldering profile for SMT process with SnAgCu series solder paste.

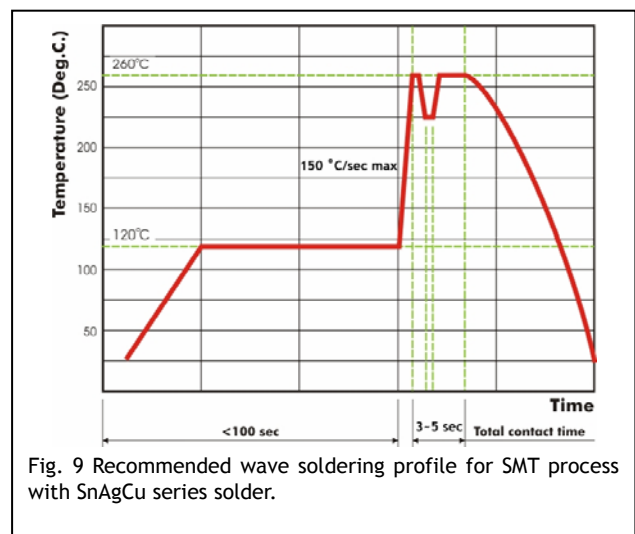

Fig. 9 Recommended wave soldering profile for SMT process with SnAgCu series solder.