

RF101 902–928 MHz RF Transmitter

Product Description

The RF101 Transmitter IC is a fully integrated, monolithic device that utilizes the direct modulation technique. It includes a double-balanced mixer as the direct-conversion modulator and a logic-controlled power amplifier. The class A power amplifier is capable of delivering 100 mW (20 dBm) peak-envelope output power with the option of switching to 10 mW and 1 mW through two digital control signals.

The RF101 features low voltage operation (2.7 V to 5 V), offers low power consumption, and comes in a small, 32-pin TQFP plastic package.

The device is intended for spread-spectrum modulation schemes in the 900 MHz ISM band (902–928 MHz).

Applications

- Direct Sequence Spread Spectrum Systems
- Frequency Hopping Spread Spectrum Systems
- Digital Cordless Telephones
- Wireless LANs
- Wireless Modems
- Wireless Security
- Inventory Control Systems

Features

- Single-Chip Baseband-to-Antenna RF Transmitter.
- Double-Balanced Mixer for Baseband-to-RF Modulation.
- LO Input Buffer @ RF.
- On-chip 50 Ω matching on LO inputs.
- Linear RF Power Amplifier with 100 mW Peak Output Power.
- 30 dB gain.
- 20 dB Power Control Range using three digitally selectable Power Amplifiers for maximum efficiency.
- 3 Battery Cell operation (2.7 V to 5 V).
- 32-Pin TQFP package.

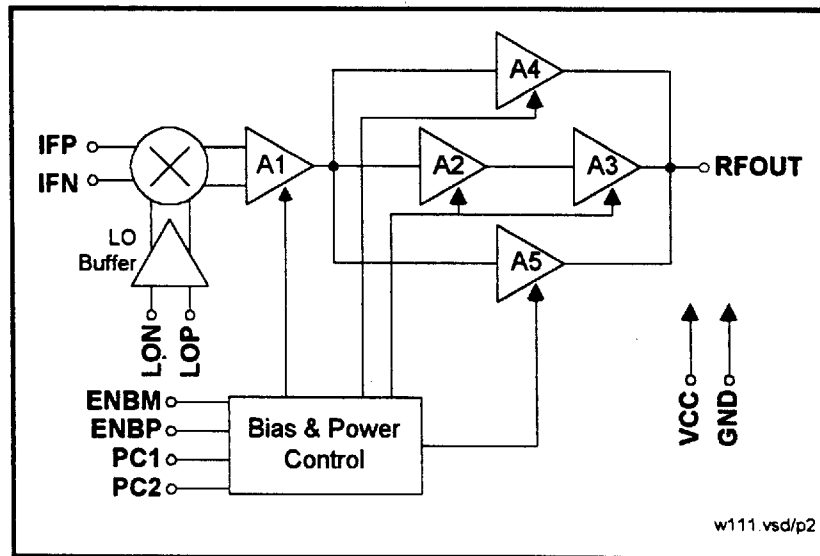

Figure 1. RF101 Transmitter Block Diagram

Technical Description

The RF101 Transmitter block diagram, shown on the previous page, consists of two sections:

1. Baseband-to-RF Modulator
2. Power Amp

Baseband-to-RF Modulator Section

Internally, the modulator consists of a double-balanced mixer and an output buffer, which drives the Power Amp input. The Modulator has two differential-input ports: the baseband (IFP, IFN) and the Local Oscillator (LO) inputs (LOP, LON). Even though the input ports are differential, they can be driven single-ended with no loss of gain. The typical IF input bandwidth is 50 MHz. The LO input can be driven with a 950 MHz (max.) signal that is as low as -10 dBm. The LO buffer can be biased up independently from the rest of the circuitry using the ENBM digital input.

Switchable Power Amplifiers Section

The Power Amp can provide 100 mW peak-envelope output power (20 dBm), that may be reduced by 10 dB or 20 dB using the digital inputs PC1 and PC2. The power output is biased in linear mode such that the intermodulation spurious products are minimized. To reduce power consumption, the bias current is reduced when either the 10 dBm or 0 dBm power mode is selected. The whole transmitter (except the LO input buffer) can be shut down independently using the ENBP digital input.

Recommendations on Layout and Implementation

1. The LO inputs are internally biased, but external AC coupling capacitors of 47 pF are needed. Even though the LO input ports are differential, they can be driven single-ended. To use the LO single-ended, simply connect the LON port to a 47 pF cap to GND (see Figure 2 below).

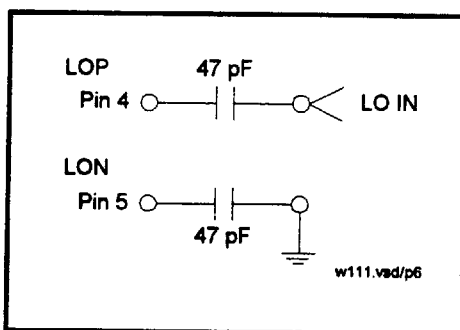

Figure 2. Single-ended LO Input

2. A 12K Ohm resistor to GND is recommended at pin 24, which provides the bias reference to the power amplifier. This provides the maximum output power from the power amplifier.

Battery life may be extended at the expense of power output by increasing the bias reference resistor value up to 16K Ohms. Varying the bias reference resistor beyond the recommended range (12K to 16K) may result in improper operation of the power amplifier. Also, a change in the bias reference resistor may also require a change in the output matching network for optimum efficiency.

3. As a general rule, the Vcc pins should have a proper bypassing circuit. A bypassing capacitor of 33 pF and a decoupling cap of 0.056 μF for low-frequency noise are recommended to all Vcc pins.

Special attention should be paid to Vcc pin 16. It is essential to keep the trace short to eliminate inductance. To ensure the proper operation of the PA, a bypassing cap of 12 pF to 22 pF from pin 16 to GND is required. However, due to layout variation, the value of the capacitor may vary. A longer trace which increases the inductance will require a smaller capacitor.

4. Proper heat-sinking may be required to prevent damage to the PA if it is operating close to maximum ratings. The maximum junction temperature allowed is 125°C for proper operation. The junction temperature is determined by the following equation:

$$T_j = T_A + \theta_{JA} \cdot P_{DC}$$

where: T_j is the junction temperature,
 T_A is the ambient temperature,
 θ_{JA} is 90°C/W, and
 P_{DC} is the DC power dissipation.

5. The Power Amplifier output port requires a matching network for maximum power transfer (refer to Figure 3 below for an example of a matching circuit). However, the values are layout-sensitive. A longer trace will require a smaller capacitor.

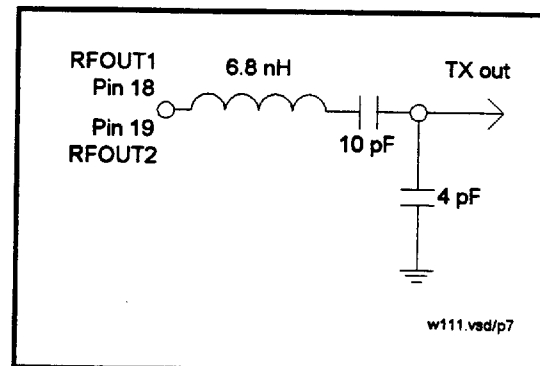

Figure 3. Typical PA Output Matching

Interface Description

The RF101 interface signal diagram is shown in Figure 5, and the corresponding interface signals are described by functional group in Table 1. The signal pinout diagram for the RF101 is shown in Figure 4.

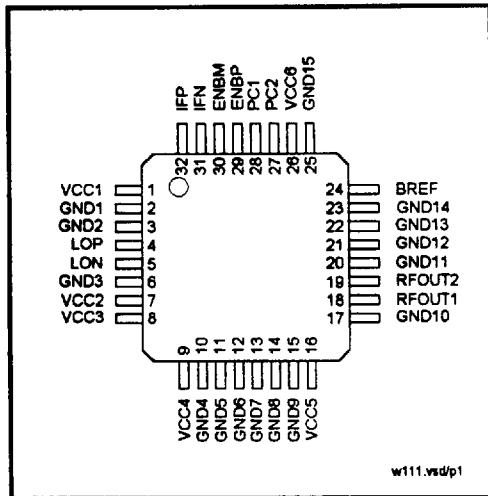

Figure 4. RF101 Pin Signals – 32-Pin TQFP

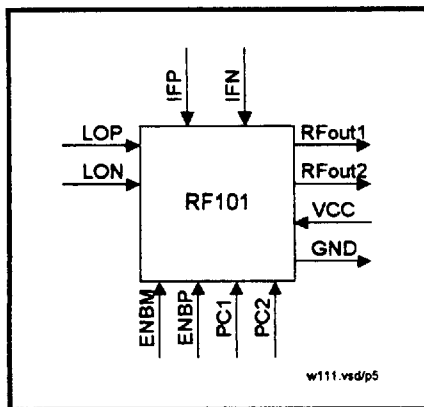

Figure 5. RF101 Signal Interface Diagram

Table 1. Pin Description

Pin	Name	Description
1	VCC1	Reference power supply.
2	GND1	Reference ground.
3	GND2	Modulator ground.
4	LOP	Modulator Differential LO input pins. Internally biased. External AC coupling capacitors are needed.
5	LON	
6	GND3	Modulator ground.
7	VCC2	Modulator power supply.
8	VCC3	
9	VCC4	Modulator power supply for output buffer.
10	GND4	Power Amp driver ground.
11	GND5	
12	GND6	
13	GND7	
14	GND8	Power Amp output stage ground.
15	GND9	
16	VCC5	Power Amp driver power supply.
17	GND10	Power Amp output stage ground.
18	RFOUT1	Power Amp output. It should be connected to the power supply through an external choke, and to the antenna or filter matching circuit.
19	RFOUT2	
20	GND11	Power Amp output stage ground.
21	GND12	
22	GND13	
23	GND14	
24	BREF	Bias Reference (a 12K Ohm resistor is recommended).
25	GND15	Power Amp bias control circuit ground.
26	VCC6	Power Amp bias control circuit power supply.
27	PC2	Digital control input pins for selecting output power.
28	PC1	
29	ENBP	Power down digital input for modulator and power amp.
30	ENBM	Power down for reference and LO input. Turns off whole chip.
31	IFN	Modulator Differential IF input pins. Internally based. External AC coupling capacitors are needed.
32	IFP	

Transmitter Specifications

Electrical specifications are given below in Table 2.
Absolute maximum ratings are given below in Table 3.

Table 2. Electrical Specifications*

Test Conditions: $T_A = 25\text{ }^\circ\text{C}$, $V_{CC} = 3.6\text{ V}$, $f_{LO} = 915\text{ MHz}$, $P_{LO} = -10\text{ dBm}$, $f_{IF} = 200\text{ KHz}$, $V_{IF} = 120\text{ mV}_{pp}$, $R_{BREF} = 12\text{K Ohm}$

Parameter	Min	Typ	Max	Units
Gain Variation vs. Frequency 902 MHz < f_{LO} < 928 MHz		0.5	1.5	dB
Peak-Envelope Output Power:				
PC1,2 = L,L		21		dBm
PC1,2 = L,H		9		dBm
PC1,2 = H,L		0		dBm
PC1,2 = H,H		-30		dBm
Total Supply Current:				
PC1,2 = L,L		175		mA
PC1,2 = L,H		55		mA
PC1,2 = H,L		33		mA
Standby		1		μA
Modulator Supply Current		20		mA
IM3:				
PC1,2 = L,L		-18		dBc
PC1,2 = L,H		-23		
PC1,2 = H,L		-23		
IP3 PC1,2 = L,L		30		dBm
Output VSWR for Unconditional Stability			10	
LO Input Power Required	-13	-10	0	dBm
LO Suppression		-25		dBc
LO Return Loss (902–928 MHz)			-9.5	dB
LO-to-IF Input Isolation @ 915 MHz		48		dB
RF Output-to-IF Input Isolation @ 915 MHz		48		dB
RF Output-to-LO Isolation @ 915 MHz		55		dB
IF Input Impedance		10		$\text{K}\Omega$
IF Input Bandwidth		50		MHz
LO Input Impedance		50		Ω
Power Supply Range	2.7		5	V
Operating Temperature Range	-10	25	70	$^\circ\text{C}$

* These measurements are taken with the recommended PA output matching and bypassing caps for V_{CC} , as described in the Technical Description section.

Table 3. Absolute Maximum Ratings

Parameter	Symbol	Min	Max	Unit
Storage Temperature	T_{STG}	-40	125	$^\circ\text{C}$
Power Dissipation	P_D	-	900	mW
Supply Voltage	V_{CC}	0	5.5	V
Input Voltage Range	-	GND	VCC	V
LO Input Power	P_{LO}	-	5	dBm
IF Input Level (single-ended)	V_{IF}	-	500	mV _P

Module Dimensions

RF101 module dimensions are shown below in Figure 6.

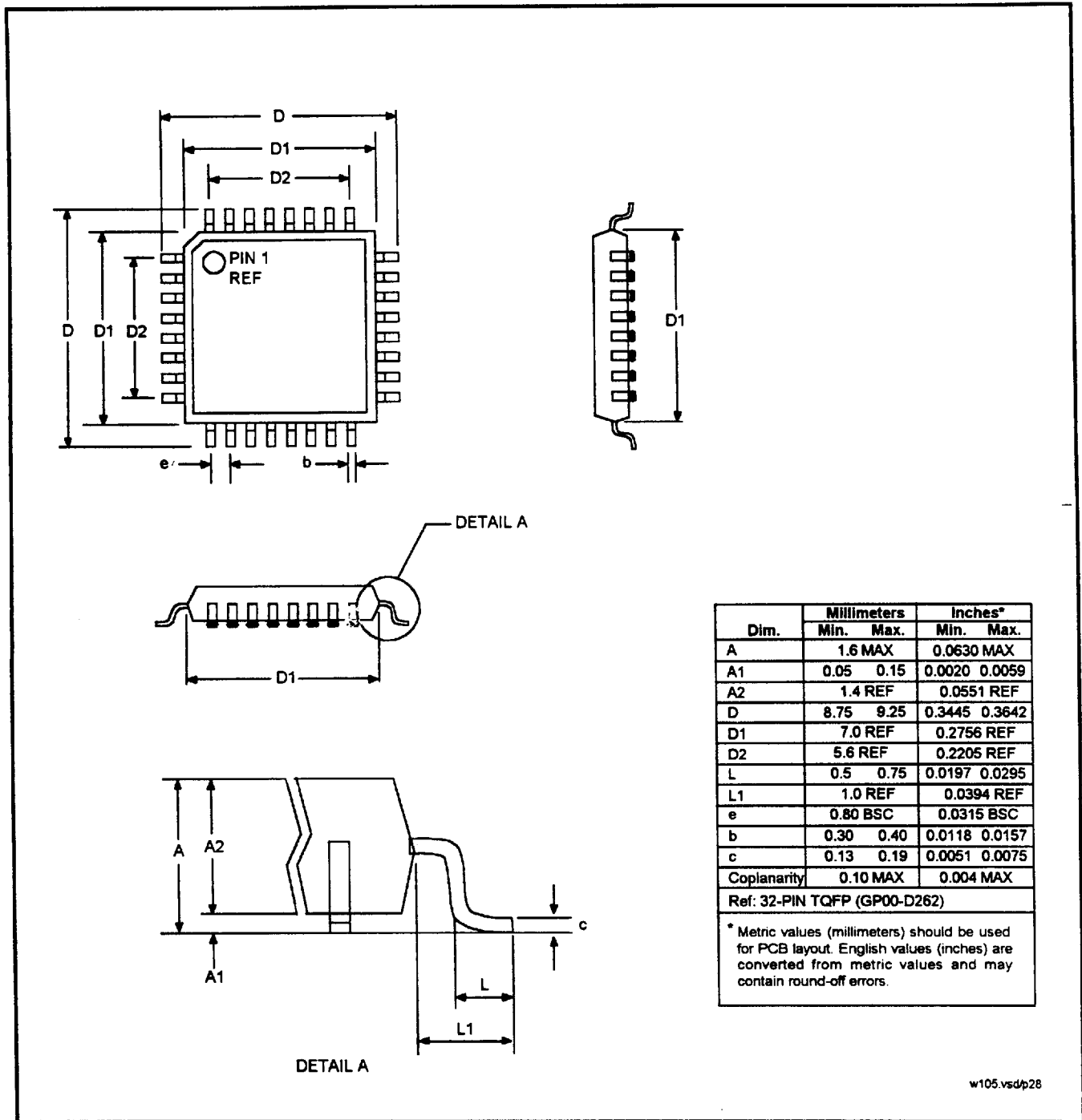

Figure 6. RF101 Transmitter Package Dimensions - 32-Pin TQFP

Information provided by Rockwell International Corporation is believed to be accurate and reliable. However, no responsibility is assumed by Rockwell International for its use, nor any infringement of patents or other rights of third parties which may result from its use. No license is granted by implication or otherwise under any patent rights of Rockwell International other than for circuitry embodied in Rockwell products. Rockwell International reserves the right to change circuitry at any time without notice. This document is subject to change without notice.