

Typical Applications

- AMPS/ETACS Cellular Handsets
- CDPD Portable Data Cards
- 900MHz ISM Band Equipment
- Commercial and Consumer Systems
- Portable Battery-Powered Equipment

Product Description

The RF2131 is a high-power, high-efficiency amplifier IC. The device is manufactured on an advanced Gallium Arsenide Heterojunction Bipolar Transistor (HBT) process, and has been designed for use as the final RF amplifier in AMPS and ETACS handheld equipment, spread spectrum systems, CDPD, and other applications in the 800MHz to 950MHz band. On-board power control provides over 30dB of control range with an analog voltage input, and provides power down with a logic "low" for standby operation. Although it is intended for class C operation, linear class AB operation can be achieved by raising the bias level. The device is self-contained with 50Ω input and the output can be easily matched to obtain optimum power and efficiency characteristics.

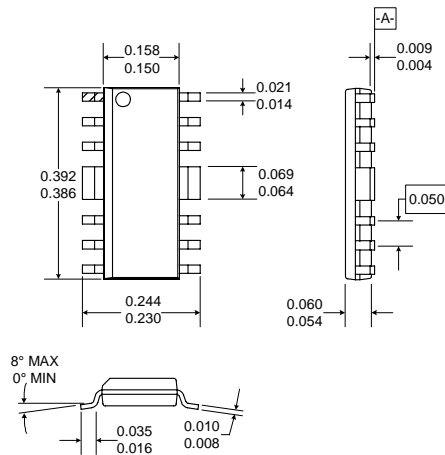

Optimum Technology Matching® Applied

- Si BJT GaAs HBT GaAs MESFET
 Si Bi-CMOS SiGe HBT Si CMOS

Package Style: Standard Batwing

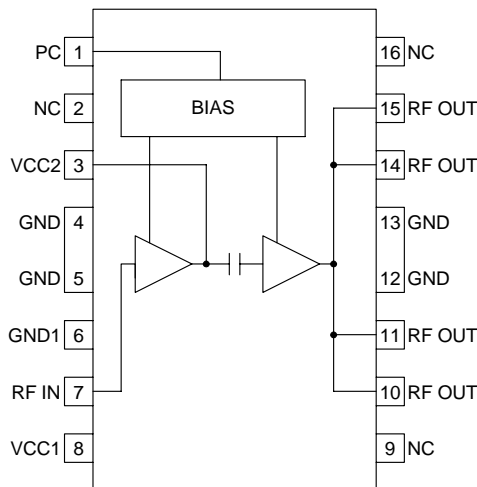

Functional Block Diagram

Features

- Single 4.0V to 7.0V Supply
- 1.2W Output Power
- 25dB Gain With Analog Gain Control
- 64% Efficiency
- Digitally Controlled Power Down Mode
- 800MHz to 950MHz Operation

Ordering Information

RF2131 High Efficiency AMPS/ETACS Amplifier
 RF2131 PCBA Fully Assembled Evaluation Board

RF Micro Devices, Inc.
 7628 Thorndike Road
 Greensboro, NC 27409, USA

Tel (336) 664 1233
 Fax (336) 664 0454
<http://www.rfmd.com>

RF2131

Absolute Maximum Ratings

Parameter	Rating	Unit
Supply Voltage	-0.5 to +8.5	V _{DC}
Power Control Voltage (V _{PC})	-0.5 to +4.5	V
DC Supply Current	570	mA
Input RF Power	+12	dBm
Output Load VSWR	10:1	
Operating Case Temperature	-40 to +100	°C
Ambient Operating Temperature	-40 to +85	°C
Storage Temperature	-40 to +150	°C



Caution! ESD sensitive device.

RF Micro Devices believes the furnished information is correct and accurate at the time of this printing. However, RF Micro Devices reserves the right to make changes to its products without notice. RF Micro Devices does not assume responsibility for the use of the described product(s).

2

POWER AMPLIFIERS

Parameter	Specification			Unit	Condition
	Min.	Typ.	Max.		
Overall					T=25 °C, V _{CC} =4.8V, V _{PC} set for P _{OUT} =+31 dBm, Freq=836MHz As configured in Application schematics
Operating Frequency Range		824 to 849		MHz	
Usable Frequency Range		800 to 950		MHz	
Maximum CW Output Power	+30.5	+31		dBm	Depends on output matching
Total CW Efficiency	55	64		%	At Max Output
DC Current at 1.2W Output		400		mA	As configured in Application Circuit #1
Input Power for 1.2W output		+6	+8	dBm	
Noise Power Output		-90	-85	dBm/30 kHz	In 869 - 894 MHz band (any gain or input power setting)
OFF Isolation	20	25		dB	V _{PC} =0V, Input Power=+6 dBm
Second Harmonic		-30	-25	dBc	Depends upon external matching. Second harmonic levels directly from the IC are approximately 20 to 25dBc
Input VSWR			<2:1		
Input Impedance		50		Ω	
Power Down Control					
Turn On/Off Time			100	ns	
V _{PC} "OFF" Voltage	0.2	0.5		V	
V _{PC} "ON" Voltage		3.6	4.0	V	
Power Supply					
Voltage		4.8		V	Specifications
Voltage	4.0		7.0	V	Operating Limits

Pin	Function	Description	Interface Schematic
1	PC	Power Control. When this pin is "low", all circuits are shut off. A "low" is typically 0.5V or less at room temperature. During normal operation this pin is the power control. Control range varies from about 2V for 0dBm to 3.6V for +31dBm RF output power. The maximum power that can be achieved depends on the actual output matching; see the application information for more details.	
2	NC	Not connected.	
3	VCC2	Power supply for the driver stage and interstage matching. A shunt capacitor is required for tuning the interstage to the proper frequency. The value of this capacitor depends on the operating frequency and power level. See the application information for details.	
4	GND	Ground connection. Keep traces physically short and connect immediately to the ground plane for best performance.	
5	GND	Same as pin 4.	
6	GND1	Ground connection for the driver stage. Keep traces physically short and connect immediately to the ground plane for best performance. It is recommended to use separate vias to the ground plane for this return path.	See pin 1 schematic.
7	RF IN	RF Input. This is a 50Ω input, but the actual impedance depends on the interstage matching network connected to pin 3. An external DC blocking capacitor is required if this port is connected to a DC path to ground or a DC voltage.	See pin 3 schematic.
8	VCC1	Power supply for the bias circuits. An external RF bypass capacitor is required. Keep the traces to the capacitor as short as possible, and connect the capacitor immediately to the ground plane.	See pin 1 schematic.
9	NC	This pin is not connected internally; however it needs to be connected to ground externally. This will improve performance by reducing coupling between pins.	
10	RF OUT	RF Output and power supply for the output stage. The four output pins are combined, and bias voltage for the final stage is provided through these pins. The external path must be kept symmetric until combined to ensure stability. An external matching network is required to provide the optimum load impedance; see the application schematics for details.	
11	RF OUT	Same as pin 10.	See pin 10 schematic.
12	GND	Ground connection for the output stage. Keep traces physically short and connect immediately to the ground plane for best performance.	
13	GND	Ground connection for the output stage. Keep traces physically short and connect immediately to the ground plane for best performance.	
14	RF OUT	Same as pin 10.	See pin 10 schematic.
15	RF OUT	Same as pin 10.	See pin 10 schematic.
16	NC	This pin is not connected internally, however it needs to be connected to ground externally. This will improve performance by reducing coupling between pins.	

Theory of Operation and Application Information

The RF2131 is a two-stage device with 25dB gain at full power. Therefore, for +31dBm output power, the drive required to fully saturate the output is +6dBm. Based upon HBT (Heterojunction Bipolar Transistor) technology, the part requires only a single positive 4.8V supply to operate to full specification. Bias control is provided through a single pin interface, and the final stage ground is achieved through the large pins on both sides of the package. First stage ground is brought out through a separate ground pin for isolation from the output. These grounds should be connected directly with vias to the PCB ground plane. The output is brought out through the 4 output pins, and combined off-chip to form the RF output signal path.

The amplifier operates in Class AB bias mode. The final stage is "deep AB", meaning the quiescent current is very low, around 40mA. As the RF drive is increased, the final stage self-biases, causing the bias point to shift up and, at full power, draws about 340mA. The optimum load for the output stage is approximately 10Ω. This is the load at the output collector, and is created by the series inductance formed by the output bond wires, leads, and microstrip, and a shunt capacitor external to the part. With this match, a 50Ω terminal impedance is achieved. The input is matched to 50Ω with just a blocking capacitor needed. This data sheet defines the configuration for AMPS operation, but the output load may be modified slightly for ETACS operation. In any case the optimum load for 1.2W is the same at the device, and only the reactive elements must change to perform the transformation from 50Ω down to 10Ω.

The input is DC coupled; thus, a blocking cap must be inserted in series. Also, the first stage bias may be adjusted by a resistive divider with high value resistors on this pin to V_{PC} and ground. For nominal operation, however, no external adjustment is necessary as internal resistors set the bias point optimally.

V_{CC2} provides supply voltage to the first stage, as well as provides some frequency selectivity to tune to the operating band. Essentially, the bias is fed to this pin through a short microstrip. A bypass capacitor sets the inductance seen by the part, so placement of the bypass cap can affect the frequency of the gain peak. For ETACS, the capacitor placement is slightly different than for AMPS due to the frequency shift. This supply should be bypassed individually with 33pF or 100pF capacitors before being combined with V_{CC} for the out-

put stage to prevent feedback and oscillations.

The RF OUT pins provide the output power. Pins 10 and 11 should be combined externally with pins 14 and 15 with a symmetric combiner, as shown in the PCB layout. Care should be taken to ensure that the output paths are symmetric up to the point of combining. This prevents "odd-mode" cancellation from occurring wherein one side may get out-of-phase with the other, affecting efficiency and stability. Bias for the final stage is fed to this output line, and the feed must be capable of supporting the approximately 400mA of current required. Care should also be taken to keep the losses low in the bias feed and output components. DC losses in the bias choke will degrade efficiency and power.

The part will operate over a 4.0V to 4.8V range. If, for example, the full power is desired at minimum voltage, then the load can be optimized at that point. This is illustrated in Application Schematic 2. At that point, the specified efficiency and power should be attainable. As the voltage is increased, however, the output power will increase. Thus, in a system design, the ALC (Automatic Level Control) Loop will back down the power to the desired level. This will occur at a less-than-optimum efficiency, since the load is optimized for minimum voltage. If the load is set up to optimize power and efficiency at nominal operating voltage, then max efficiency should be attainable there. This case is illustrated in Application Schematic 1. As the voltage drops to minimum, power will degrade, but the efficiency tends to be maintained. For nominal 31.5dBm at 4.8V setup, as the voltage drops to 4.0V, the output power drops to 30.5dBm with a constant V_{PC} .

The HBT breakdown voltage is >20V, so nominally at 4.8V there should be no issue with overvoltage. Under extreme conditions, however, which can occur in a cellular handset environment, the supply voltage could be as high as 7.5V to 8.5V. These conditions may correspond to operation in a battery charger, especially with the battery removed, which "unloads" the supply circuit. To add to this worst-case scenario, the RF drive may be at full power during transmit, and the output VSWR could be extremely high, corresponding to a broken or removed antenna. Under all of the above conditions, the peak RF voltages could well exceed two times the supply voltage, forcing the device into breakdown. The RF2131 includes overvoltage protection diodes at the output, which begin clipping the waveform peaks at approximately 15V. This protects the device's output from breaking down under these worst-

case conditions, and provides a rugged, robust component for the system designer.

High current conditions are also potentially dangerous to any RF device. High currents lead to high channel temperatures and may force early failures. The RF2131 includes temperature compensation circuits in the bias network to stabilize the RF transistors, thus limiting the current through the amplifier and protecting the devices from damage. The same mechanism works to compensate the currents due to ambient temperature variations.

Application Schematic 1 Optimized for Efficiency at 4.8V

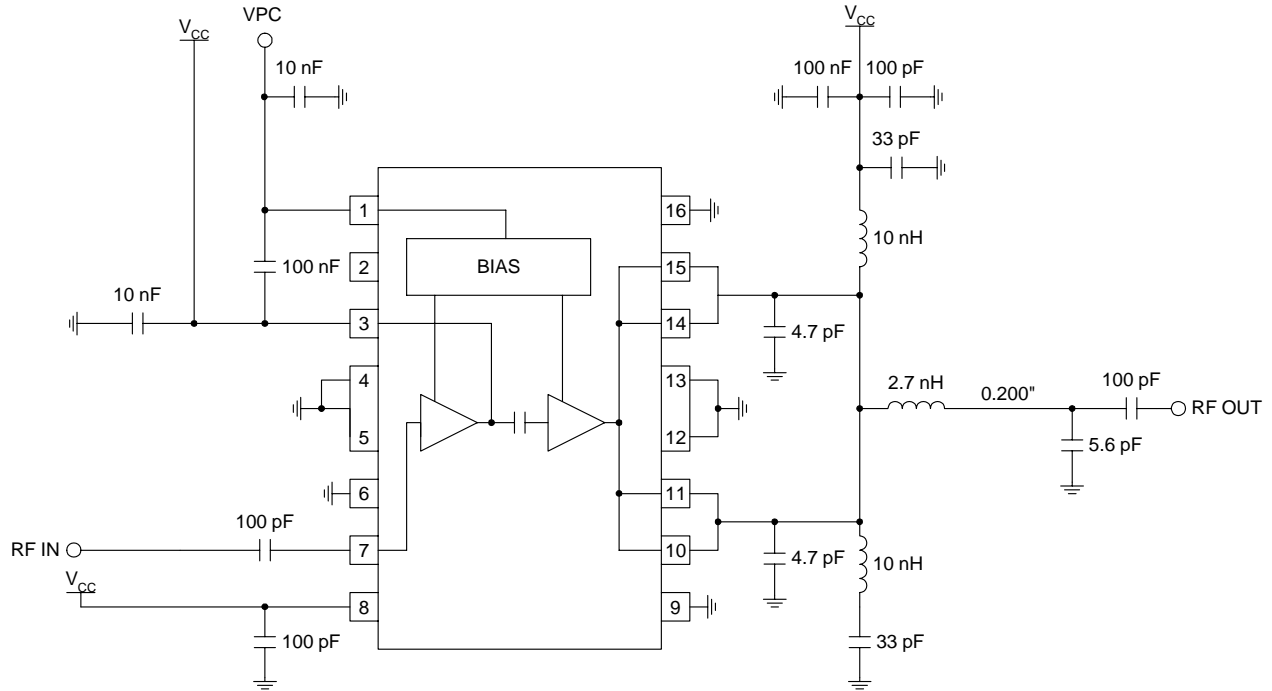

This schematic defines the optimum configuration for maximum efficiency at 4.8V. Under these conditions, as can be seen in the data plots, the power drops at 4.0V. Over 70% power-added efficiency can be achieved at +30.8dBm with 4.8V and +8dBm input level with this implementation.

Application Schematic 2 Optimized for Power and Efficiency over 4.0V to 4.8V

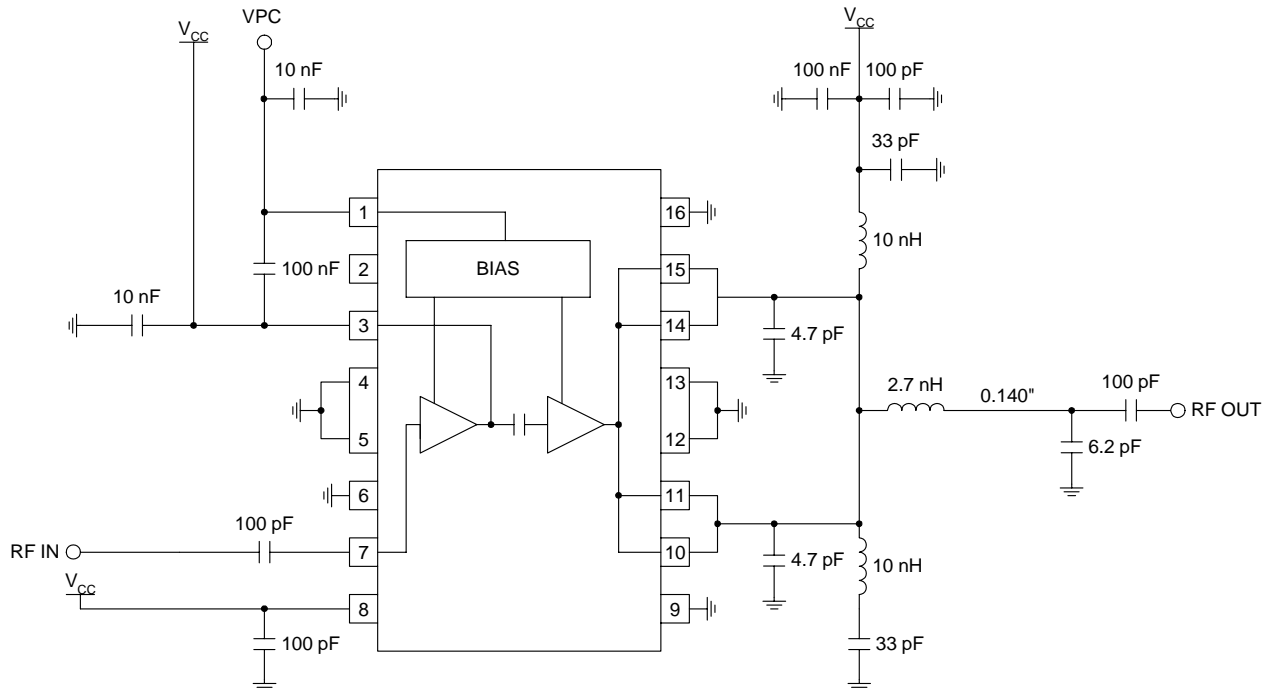

This application circuit differs from Application schematic 1 only slightly in the output tuning. The output shunt capacitor has been moved 0.060" closer to the device, and has increased from 5.6pF to 6.2pF. This retuning allows over +30.8dBm of output power to be achieved down to 4.0V, however a couple of percent points of efficiency are sacrificed. This implementation is recommended for some additional margin on output power.

Evaluation Board Schematic (Download [Bill of Materials](http://www.rfmd.com) from www.rfmd.com.)

2

POWER AMPLIFIERS

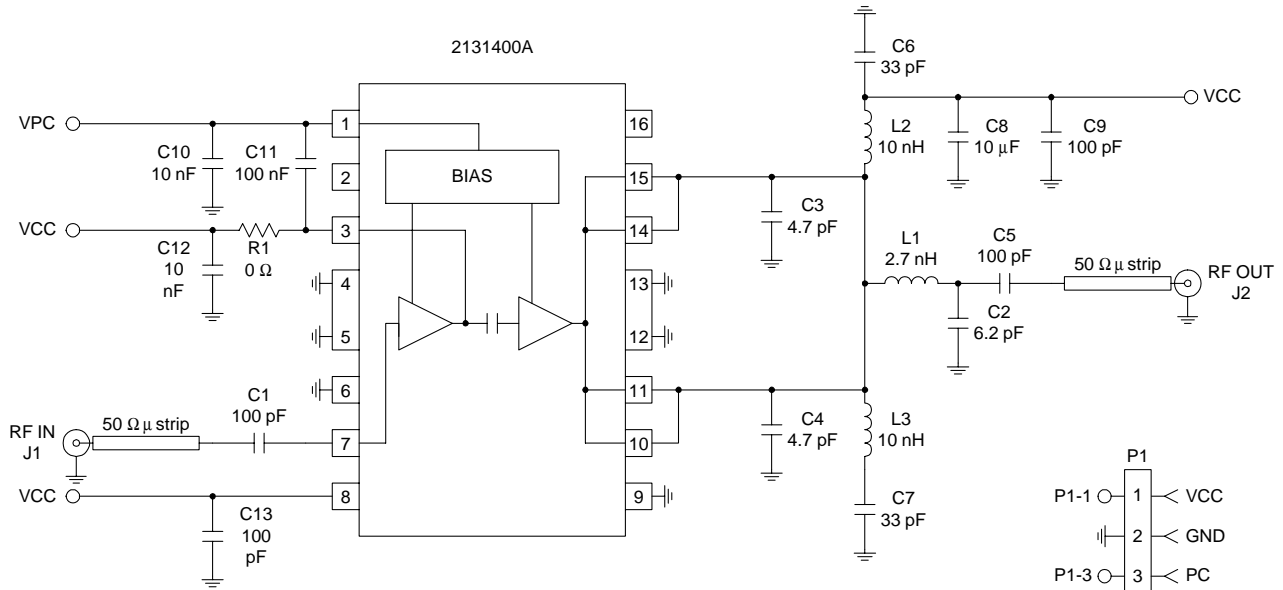

Evaluation Board Layout 3" x 2"

