

Typical Applications

- CDMA PCS LNA
- TDMA PCS LNA
- W-CDMA/CDMA2000 LNA
- General Purpose Amplification
- Commercial and Consumer Systems

Product Description

The RF2364 is a low noise amplifier with a high dynamic range designed for CDMA and TDMA PCS, as well as W-CDMA/CDMA2000 applications. The device functions as an outstanding front end low noise amplifier and the bias current can be set externally. The IC includes a power down feature used to completely turn-off the device and is featured in a standard SOT 5-lead plastic package.

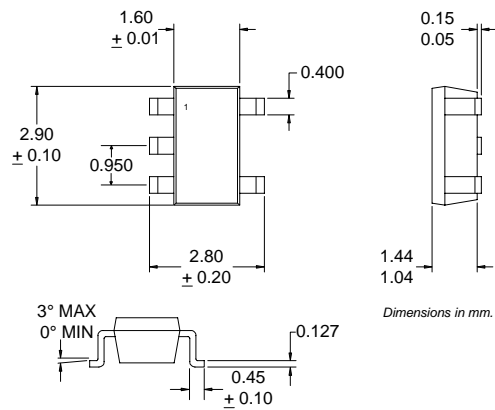

4
GENERAL PURPOSE AMPLIFIERS

Optimum Technology Matching® Applied

- | | | |
|-------------------------------------|--|--------------------------------------|
| <input type="checkbox"/> Si BJT | <input checked="" type="checkbox"/> GaAs HBT | <input type="checkbox"/> GaAs MESFET |
| <input type="checkbox"/> Si Bi-CMOS | <input type="checkbox"/> SiGe HBT | <input type="checkbox"/> Si CMOS |

Package Style: SOT 5-Lead

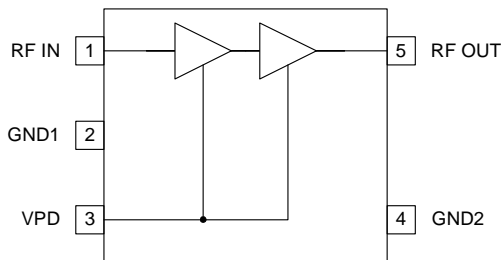

Functional Block Diagram

- Features
- Low Noise and High Intercept Point
 - 18dB Gain
 - Power Down Control
 - Single 3.0V Power Supply
 - PCS and W-CDMA Band Operation
 - 1.8GHz to 2.5GHz Operation

Ordering Information

RF2364	3V PCS Low Noise Amplifier
RF2364 PCBA	Fully Assembled Evaluation Board

RF Micro Devices, Inc.
7625 Thorndike Road
Greensboro, NC 27409, USA

Tel (336) 664 1233
Fax (336) 664 0454
<http://www.rfmd.com>

Absolute Maximum Ratings

Parameter	Rating	Unit
Supply Voltage	-0.5 to +8.0	V _{DC}
Input RF Level	+10	dBm
Storage Temperature	-40 to +150	°C



Caution! ESD sensitive device.

RF Micro Devices believes the furnished information is correct and accurate at the time of this printing. However, RF Micro Devices reserves the right to make changes to its products without notice. RF Micro Devices does not assume responsibility for the use of the described product(s).

Parameter	Specification			Unit	Condition
	Min.	Typ.	Max.		
Operating Range					
Overall Frequency Range	1930		1990	MHz	
Supply Voltage (V _{CC})	2.7	3.0	3.3	V	
Power Down Voltage (V _{PD})	2.7		2.9	V	For normal operation
			0.9	V	For power down operation
Current Consumption		17.0	23.5	mA	V _{CC} =3.0V, Values reflect I _{CC} +I _{PD}
Power Down Current			10	μA	V _{CC} =3.0V, V _{PD} ≤0.9V
Operating Ambient Temperature	-40		+85	°C	
Input Impedance		50		Ω	
Output Impedance		50		Ω	
Low Noise Amplifier Performance					
Power Gain		18	21	dB	T=25°C V _{CC} =3.0V, I _{CC} =17mA
Noise Figure		1.8		dB	
Input IP3		+5		dBm	V _{CC} =3.0V
Input VSWR			2:1		
Output VSWR			2:1		
Input P1dB		-8.5		dBm	With external matching components.

Pin	Function	Description	Interface Schematic
1	RF IN	RF input pin. This pin is DC coupled and matched to 50Ω.	
2	GND1	Ground connection. Keep traces physically short and connect immediately to ground plane for best performance.	
3	VPD	For low noise amplifier applications, this pin is used to control the bias current. See plots for bias current settings. An external resistor (R1) can be used to set the bias current for any V_{PD} voltage (See Application Note). For driver amplifier applications, this is the Power Down pin for the IC. $V_{PD}=2.8V \pm 0.1V$ is required for proper operation. $V_{PD}<0.9V$ turns off the Part. External RF bypassing is required. The trace length between the pin and the bypass capacitors should be minimized. The ground side of the bypass capacitors should connect immediately to ground plane. Nominal current required for $V_{PD}=2.8V$ is 2.0mA typical and 3.0mA Max (@ $V_{PD}=2.9V$).	
4	GND2	Ground connection. Keep traces physically short and connect immediately to ground plane for best performance.	
5	RF OUT	Amplifier Output pin. This pin is an open-collector output. It must be biased to either V_{CC} or pin 4 through a choke or matching inductor. This pin is typically matched to 50Ω with a shunt bias/matching inductor and series blocking/matching capacitor. Refer to application schematics.	

Application Notes

Power Down Pin Resistor

The Power Down pin (pin 3) of the RF2364 3V Low Noise Amplifier should be maintained at 2.7V to 2.9V for proper operation. This voltage range ensures the correct bias current will be present at the Power Down pin of the device. However, an external series resistor may be used to allow various operating voltages at this pin (see R1 in Application Schematics). The required value for this resistor may be roughly calculated by using the operating input voltage to the Power Down pin, the desired voltage at the device, and the typical current consumption for the Power Down pin, along with Ohms law.

For example, assume the design will supply 3.3V to the Power Down pin of the device, but the biasing circuitry internal to the RF2364 requires 2.8V, and the power down bias current is known to typically be 5.5mA, then the required value from R1 would be found from:

$$\frac{3.3V - 2.8V}{5.5mA} = 90.9\Omega$$

Application Schematic PCS Band

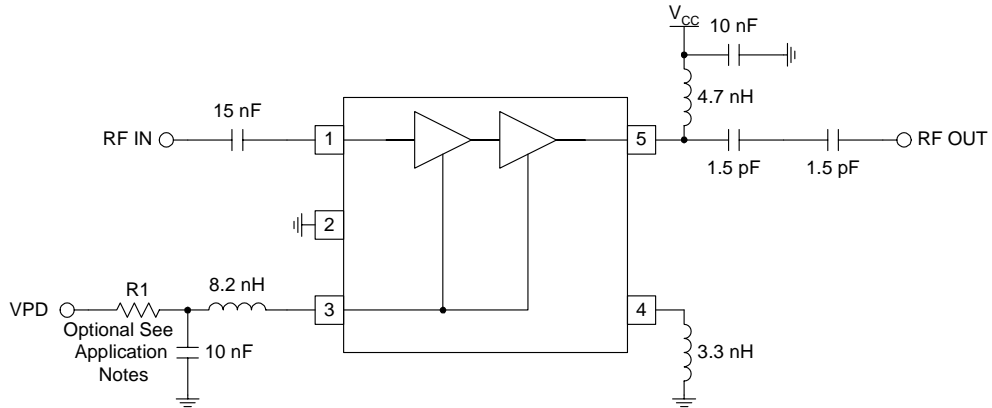

Application Schematic W-CDMA Band

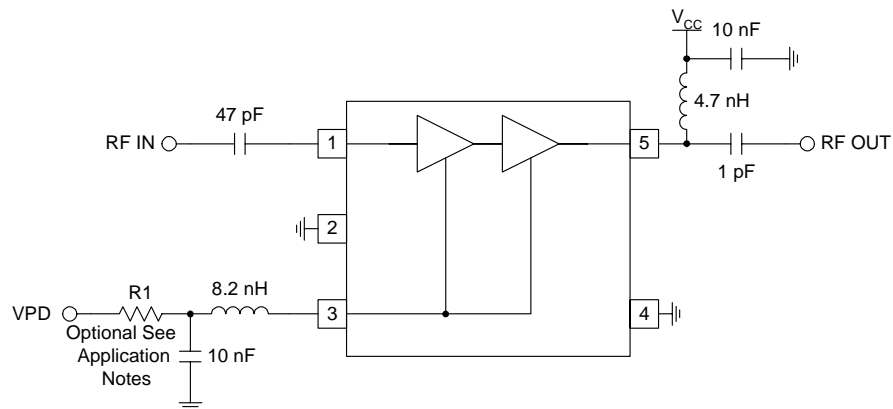

4
GENERAL PURPOSE
AMPLIFIERS

Evaluation Board Schematic - PCS Band

(Download [Bill of Materials](http://www.rfmd.com) from www.rfmd.com.)

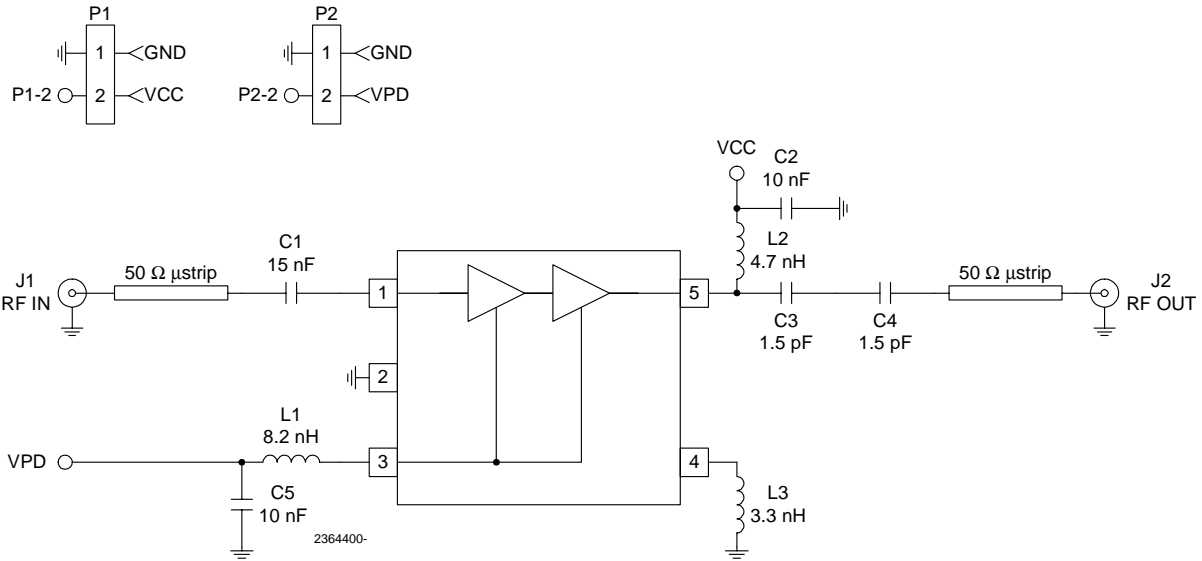

4

GENERAL PURPOSE
AMPLIFIERS

Evaluation Board Layout
Board Size 1" x 1"
Board Thickness 0.031"; Board Material FR-4

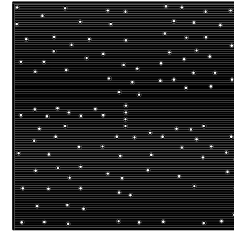
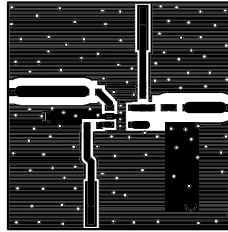
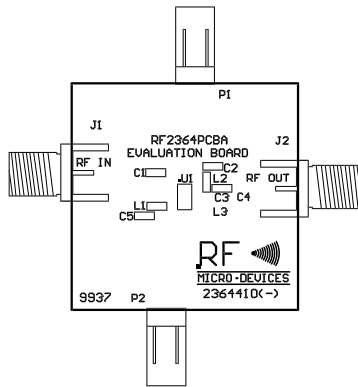

Gain versus V_{CC}
 $V_{PD}=2.8V$, Frequency=1960MHz

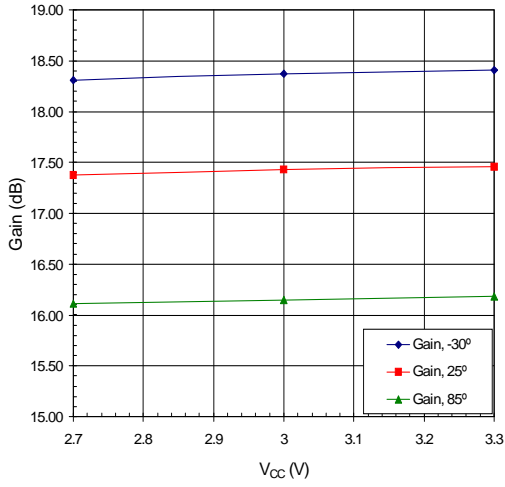

IIP3 versus V_{CC}
 $V_{PD}=2.8V$, Frequency=1960MHz

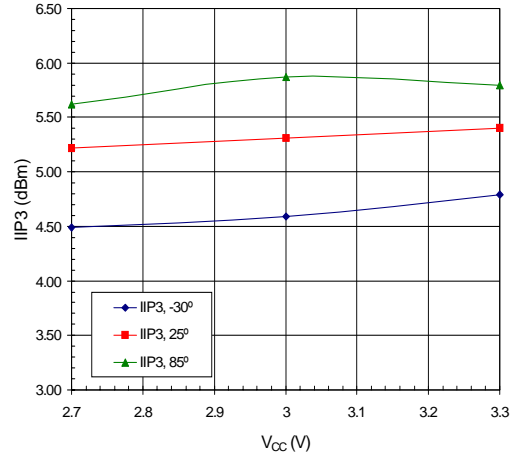

Noise Figure versus V_{CC}
 $V_{PD}=2.8V$, Frequency=1960MHz

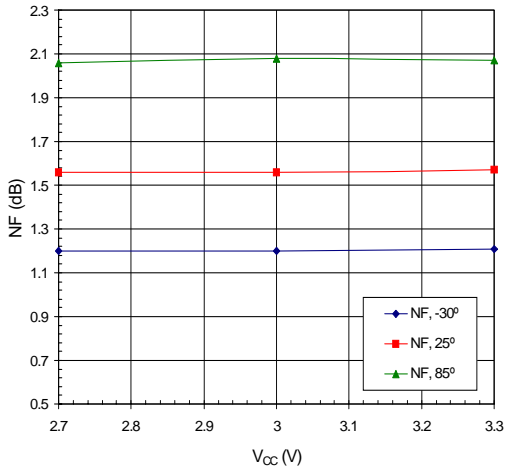

Input P1dB versus V_{CC}
 $V_{PD}=2.8V$, Frequency=1960MHz

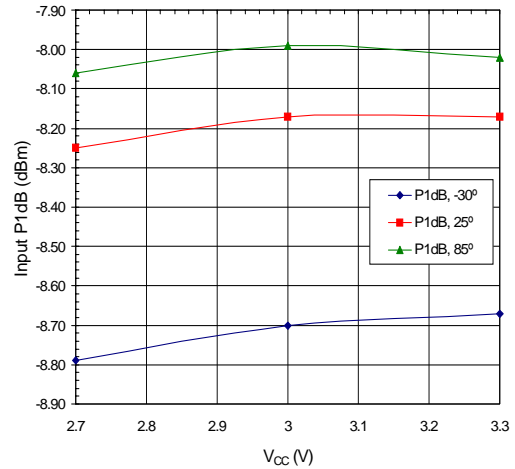

I_{CC} versus V_{CC}
 $V_{PD}=2.8V$, Frequency=1960MHz

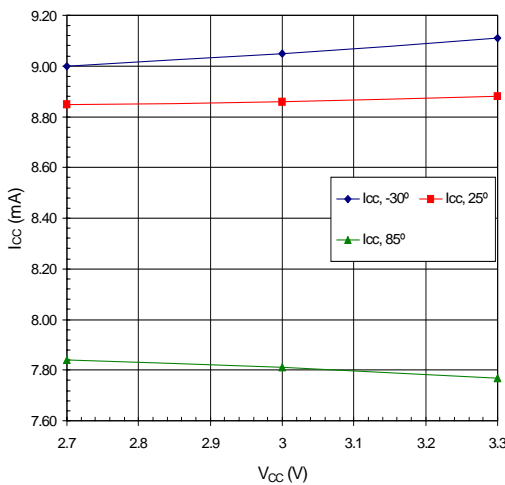

Gain versus V_{PD}
 $V_{CC}=3.0V$, Frequency=1960MHz

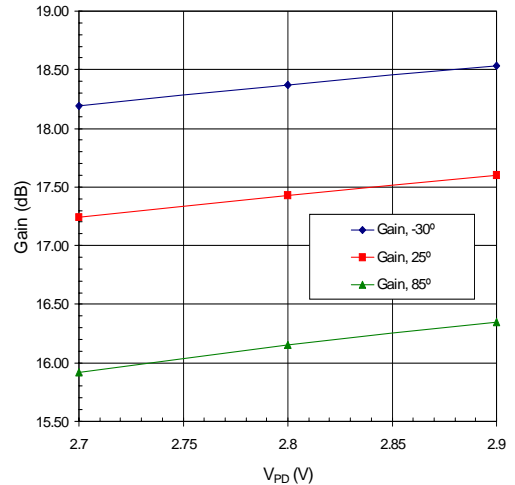

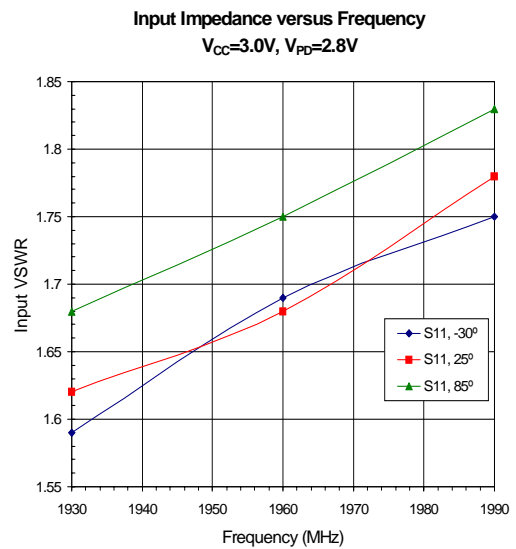
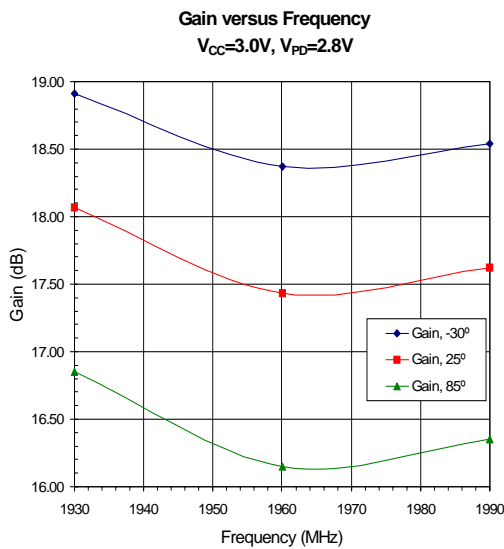
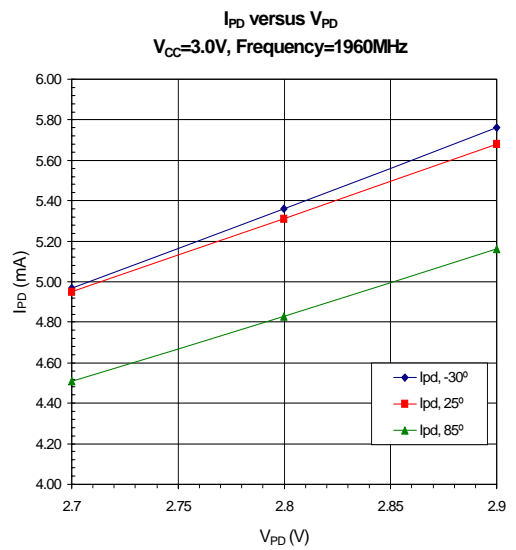
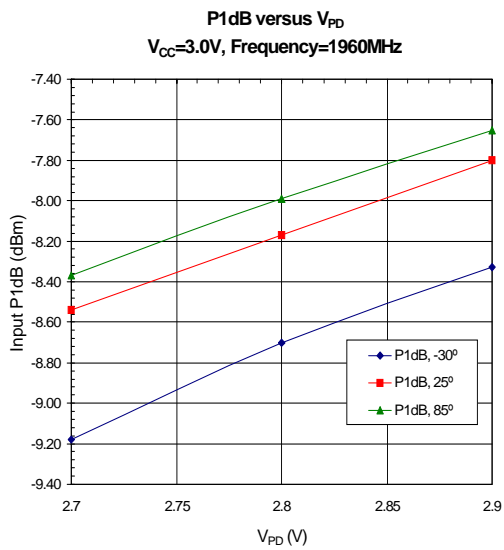
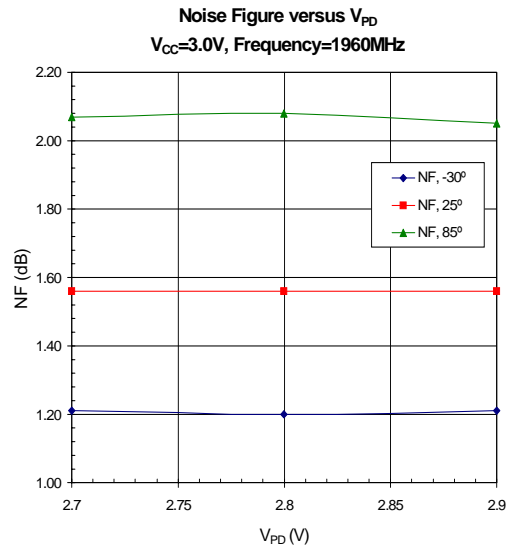
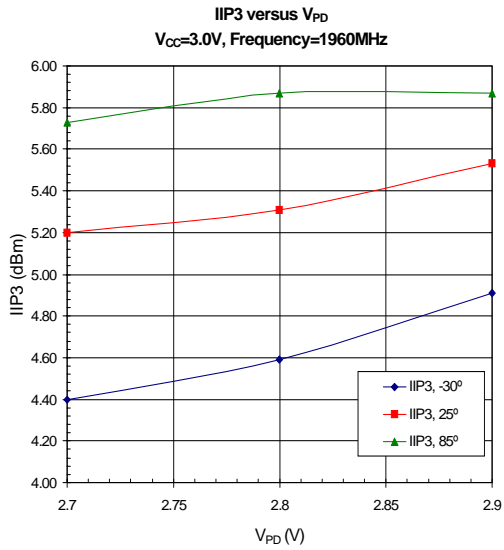

Output Impedance versus Frequency
 $V_{CC}=3.0V, V_{FD}=2.8V$

