

Typical Applications

- CDMA/FM Cellular Systems
- CDMA PCS Systems
- GSM/DCS Systems
- TDMA Systems
- Spread-Spectrum Cordless Phones
- Wireless Local Loop Systems

Product Description

The RF2667 is an integrated complete IF AGC amplifier and quadrature demodulator developed for the receive section of dual-mode CDMA/FM cellular and PCS applications and for GSM/DCS and TDMA systems. It is designed to amplify received IF signals, while providing 100dB of gain control range, and demodulate to base-band I and Q signals. Noise figure, IP₃, and other specifications are designed to be compatible with the IS-98, and J-STD-018 Interim Standard for CDMA cellular communications. This circuit is part of the RFMD line of complete solutions for digital radio applications. The IC is manufactured on an advanced 15GHz F_T Silicon Bipolar process, and is packaged in a standard miniature 24-lead plastic QSOP package.

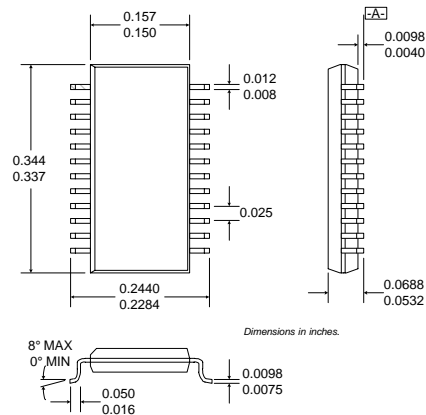

- NOTES:**
 1. Shaded lead is Pin 1.
 2. All dimensions are excluding mold flash.
 3. Lead coplanarity: 0.005 with respect to datum "A".

Optimum Technology Matching® Applied

- Si BJT GaAs HBT GaAs MESFET
 Si Bi-CMOS SiGe HBT Si CMOS

Package Style: QSOP-24

Features

- Similar to RF9957 with Higher I/Q Output Voltage
- Supports Dual Mode Operation
- Digitally Controlled Power Down Mode
- 2.7V to 3.3V Operation
- IF AGC Amp with 100dB Gain Control

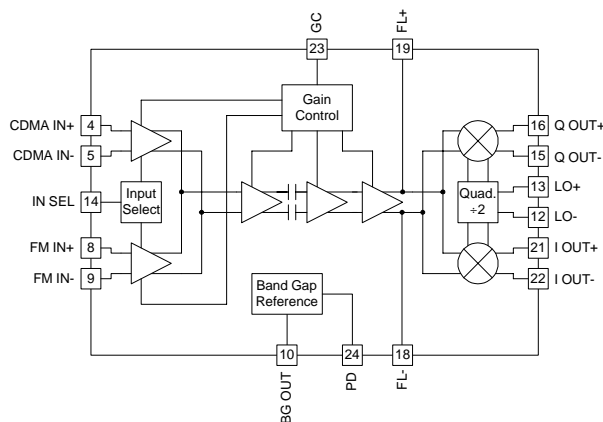

Functional Block Diagram

Ordering Information

- RF2667 Receive AGC and Demodulator
 RF2667 PCBA Fully Assembled Evaluation Board

RF Micro Devices, Inc.
 7625 Thorndike Road
 Greensboro, NC 27409, USA

Tel (336) 664 1233
 Fax (336) 664 0454
<http://www.rfmd.com>

RF2667

Absolute Maximum Ratings

Parameter	Rating	Unit
Supply Voltage	-0.5 to +5	V _{DC}
Power Down Voltage (V _{PD})	-0.5 to V _{CC} +0.7	V _{DC}
Input RF Power	+3	dBm
Ambient Operating Temperature	-40 to +85	°C
Storage Temperature	-40 to +150	°C



Caution! ESD sensitive device.

RF Micro Devices believes the furnished information is correct and accurate at the time of this printing. However, RF Micro Devices reserves the right to make changes to its products without notice. RF Micro Devices does not assume responsibility for the use of the described product(s).

7
QUADRATURE
DEMODULATORS

Parameter	Specification			Unit	Condition
	Min.	Typ.	Max.		
Overall (Cascaded)					T=25 °C, V _{CC} =3.0V, Z _{LOAD} =5kΩ, LO=170MHz @400mV _{PP} IF Freq=85MHz, Z _S =500Ω (CDMA), Z _S =850Ω (FM)
Maximum Gain	+45	+50		dB	V _{GC} =2.5V, FM or CDMA Input, Balanced
Minimum Gain		-55	-50	dB	V _{GC} =0.5V, FM or CDMA Input, Balanced
Gain Variation	-3		+3	dB	T=-20°C to +85°C, Ref = 25 °C
Input IP3	-54	-50		dBm	V _{GC} =2.5V, Maximum Gain
	-7	-4		dBm	V _{GC} =0.5V, Minimum Gain
	-39	-36		dBm	Gain = 35 dB, P _{IN} =-61dBm
Noise Figure		5	8	dB	V _{GC} =2.5V, Maximum Gain
		70	77	dB	V _{GC} =0.5V, Minimum Gain
IF Input Frequency Range	50	70 to 230	250	MHz	
IF Input Impedance	2040	2400	2760	Ω	FM or CDMA, Balanced
	1020	1200	1380	Ω	FM or CDMA, Single-ended
I/Q Frequency Range	0		50	MHz	
I/Q Amplitude Balance		0.1	0.5	dB	
I/Q Phase Balance		1	5	deg	
Max I/Q Output Voltage	2.0	2.4		V _{PP}	Balanced, maximum output level
I/Q Output Impedance	1020	1200	1380	Ω	Single-ended
	2040	2400	2760	Ω	Balanced
I/Q DC Output		2.0		V _{DC}	Common Mode
I/Q DC Offset		20		mV _{DC}	I OUT+ to I OUT-; Q OUT+ to Q OUT-
LO Input Frequency Range	100	140 to 460	600	MHz	
LO Input Level	60	400	600	mV _{PP}	Balanced
LO Input Impedance	680	800	920	Ω	Balanced
	340	400	460	Ω	Single Ended
Power Supply					
Supply Voltage	2.7	3.0	3.3	V	
Current Consumption		20	23	mA	CDMA Mode
		20	23	mA	FM Mode
Power Down Current			20	μA	
V _{PD} HIGH Voltage	V _{CC} -0.7			V	
V _{PD} LOW Voltage			0.5	V	

Pin	Function	Description	Interface Schematic
1	VCC1	Supply voltage for the LO flip-flop divider and limiting amp. This pin may be connected in parallel with pins 2 and 3. It should be bypassed by a 10nF capacitor. The trace length between the pin and the bypass capacitor should be minimized. The ground side of the bypass capacitor should connect immediately to ground plane. The part is designed to work from a 2.7V to 3.3V supply.	
2	VCC2	Supply voltage for the bandgap, gain control bias circuitry, and AGC stages 2, 3, and 4. This pin may be connected in parallel with pins 1 and 3. It should be bypassed by a 10nF capacitor. The trace length between the pin and the bypass capacitor should be minimized. The ground side of the bypass capacitor should connect immediately to ground plane. The part is designed to work from a 2.7V to 3.3V supply.	
3	VCC3	Supply voltage for the FM and CDMA AGC input stages. This pin may be connected in parallel with pins 1 and 2. It should be bypassed by a 10nF capacitor. The trace length between the pin and the bypass capacitor should be minimized. The ground side of the bypass capacitor should connect immediately to ground plane. The part is designed to work from a 2.7V to 3.3V supply.	
4	CDMA IN+	CDMA Balanced Input pin. This pin is internally DC biased and should be DC blocked if connected to a device with a DC level present. For single-ended input operation, one pin is used as an input and the other CDMA input is AC coupled to ground. The balanced input impedance is 2.4k Ω , while the single-ended input impedance is 1.2k Ω .	
5	CDMA IN-	Same as pin 4, except complementary input.	See pin 4.
6	GND	Ground connection. Keep traces physically short and connect immediately to ground plane for best performance.	
7	GND	Same as pin 6.	
8	FM IN+	FM Balanced Input pin. This pin is internally DC biased and should be DC blocked if connected to a device with DC present. For single-ended input operation, one pin is used as an input and the other FM input is AC coupled to ground. The balanced input impedance is 2.4k Ω , while the single-ended input impedance is 1.2k Ω .	
9	FM IN-	Same as pin 8, except complementary input.	See pin 8.
10	BG OUT	Bandgap Voltage Reference. This voltage, constant over temperature and supply variation, is used to bias internal circuits. A 10nF external bypass capacitor is required. The trace length between the pin and the bypass capacitor should be minimized. The ground side of the bypass capacitor should connect immediately to ground plane.	
11	DEC	AGC decoupling pin. An external bypass capacitor of 10nF capacitor is required. The trace length between the pin and the bypass capacitor should be minimized. The ground side of the bypass capacitor should connect immediately to ground plane.	
12	LO-	LO Balanced Input pin. This pin is internally DC biased and should be DC blocked if connected to a device with DC present. For single-ended input operation, one pin is used as an input and the other LO input is AC coupled to ground. The frequency of the signal applied to these pins is internally divided by a factor of 2, hence the carrier frequency for the modulator becomes one half of the applied frequency. The single-ended input impedance is 400 Ω (balanced is 800 Ω). The LO input may be driven single-ended but balanced provides optimum gain and phase balance.	
13	LO+	Same as pin 12, except complementary input.	See pin 12.

RF2667

Pin	Function	Description	Interface Schematic
14	IN SEL	Selects between CDMA and FM mode. This is a digitally controlled input. A logic "high" ($\geq V_{CC} - 0.7V_{DC}$) selects CDMA mode. A logic "low" ($< 0.5V_{DC}$) selects FM mode. The impedance on this pin is $30k\Omega$.	
15	Q OUT-	Balanced Baseband Output of Q Mixer. This pin is internally DC biased and should be DC blocked externally. This output is active in both CDMA and FM modes. The output can be used in a single-ended configuration by leaving one of the two pins unconnected, however half the output voltage will be lost. Each pin should be loaded with $2.5k\Omega$. The balanced load should be $5k\Omega$. The single-ended output impedance is $1.2k\Omega$, while the balanced output impedance is $2.4k\Omega$.	
16	Q OUT+	Same as pin 15, except complementary output.	See pin 15.
17	GND	Same as pin 6.	
18	FL-	Balanced AGC Output/Demod Input. This balanced node is pinned out to allow shunt filtering of the AGC output signal as it enters the demodulator. The basic configuration of the filter should consist of a shunt inductor and shunt capacitor, both connected to the power supply, as the internal circuitry requires this power supply connection through the inductor to operate.	
19	FL+	Same as pin 18, except complementary.	See pin 18.
20	GND	Same as pin 6.	
21	I OUT+	Balanced Baseband Output of I Mixer. This pin is internally DC biased and should be DC blocked externally. This output is active in both CDMA and FM modes. The output can be used in a single-ended configuration by leaving one of the two pins unconnected, however half the output voltage will be lost. Each pin should be loaded with $2.5k\Omega$. The balanced load should be $5k\Omega$. The single-ended output impedance is $1.2k\Omega$, while the balanced output impedance is $2.4k\Omega$.	
22	I OUT-	Same as pin 21, except complementary output.	See pin 22.
23	GC	Analog Gain Control for AGC Amplifiers. The valid control range is from 0.5 to $2.5V_{DC}$. These voltages are valid for ONLY a $37k\Omega$ source impedance. The gain range for the AGC is 95 dB.	

Pin	Function	Description	Interface Schematic
24	PD	Power Down Control. When logic "high" ($\geq V_{CC}-0.3V$), all circuits are operating; when logic "low" ($\leq 0.5V$), all circuits are turned off. The input impedance of this pin is $10k\Omega$.	<p>The schematic shows a pull-up resistor connected to the PD pin and a transistor (NPN) connected to ground. The input impedance is labeled as $10k\Omega$.</p>

RF2667 Pin-Out

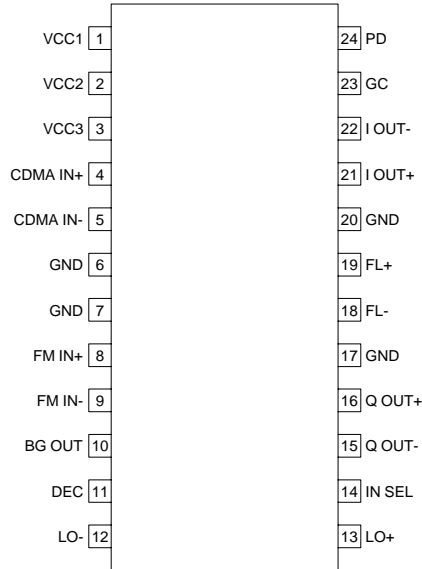

Application Schematic

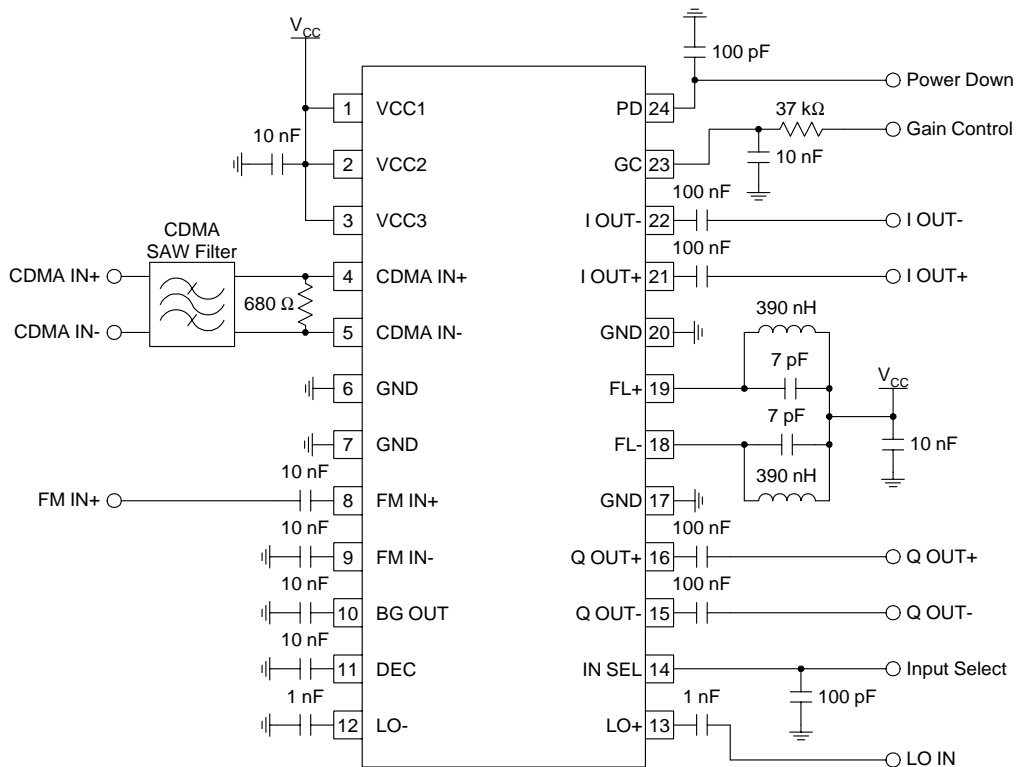

Evaluation Board Schematic 85MHz IF (Download [Bill of Materials](http://www.rfmd.com) from www.rfmd.com.)

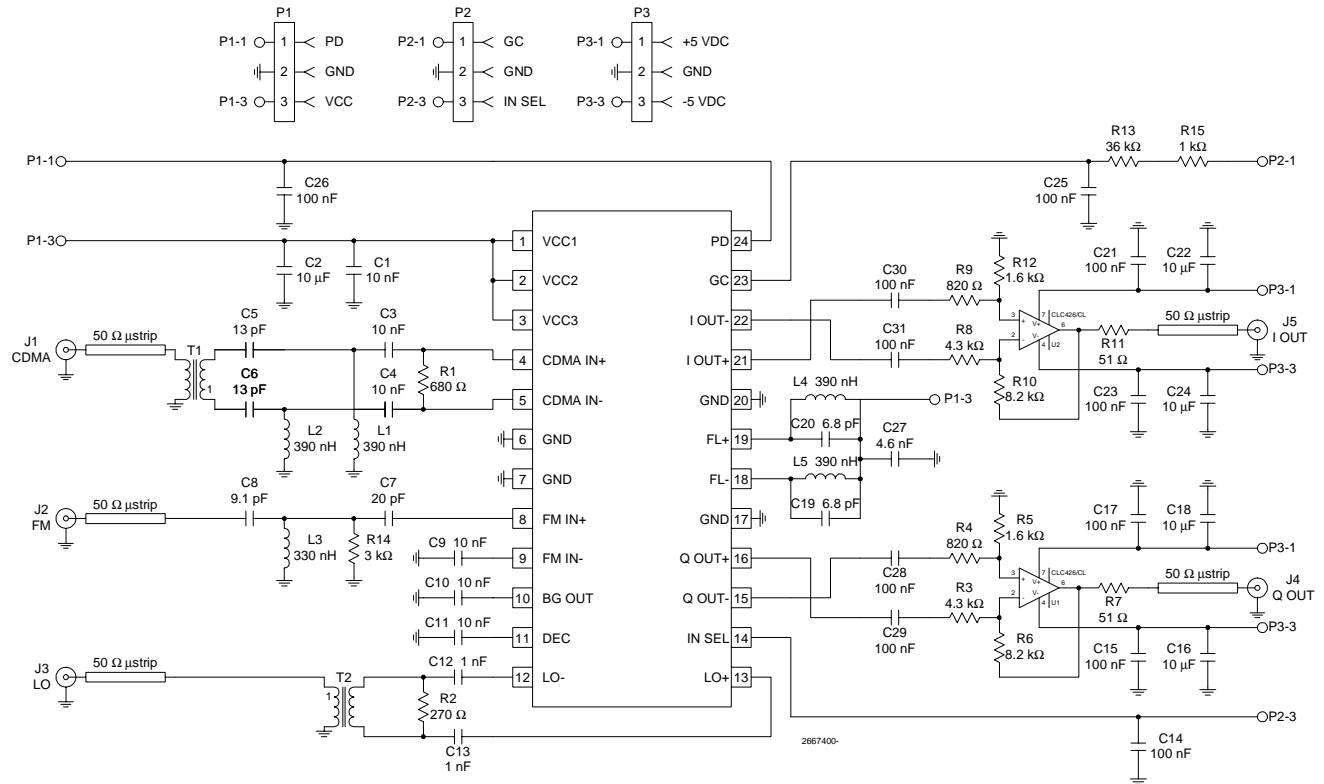

Evaluation Board Layout 3.025" x 3.025" (Assembly, Top layer, Bottom layer)

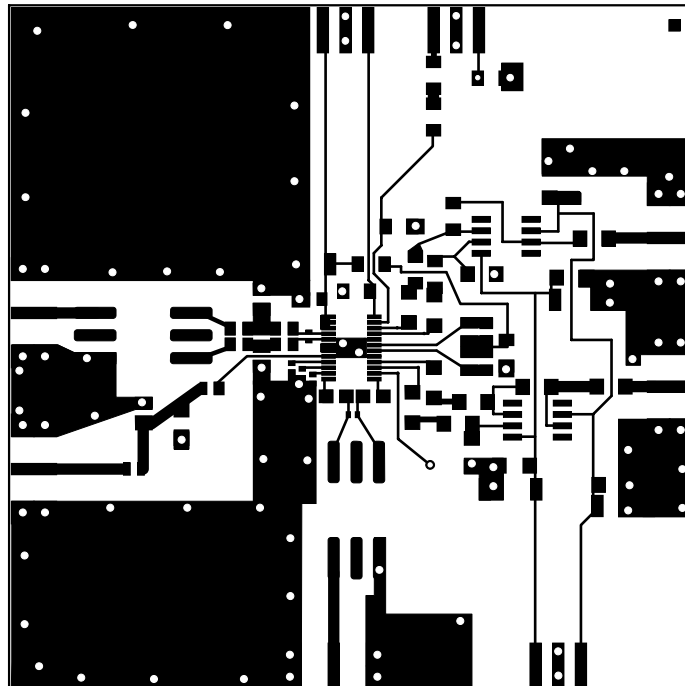
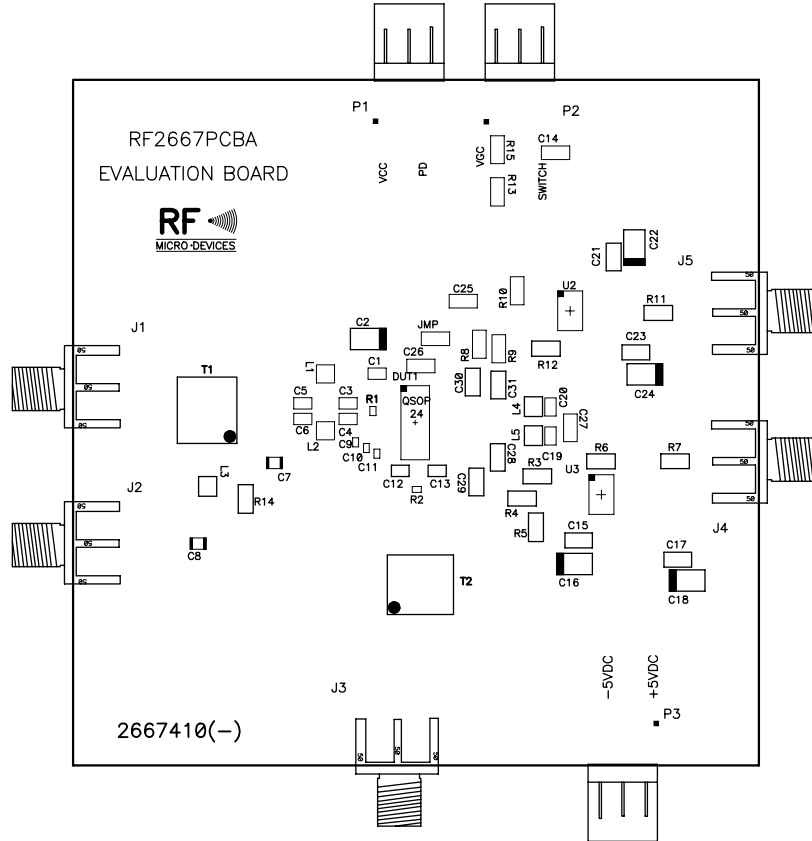

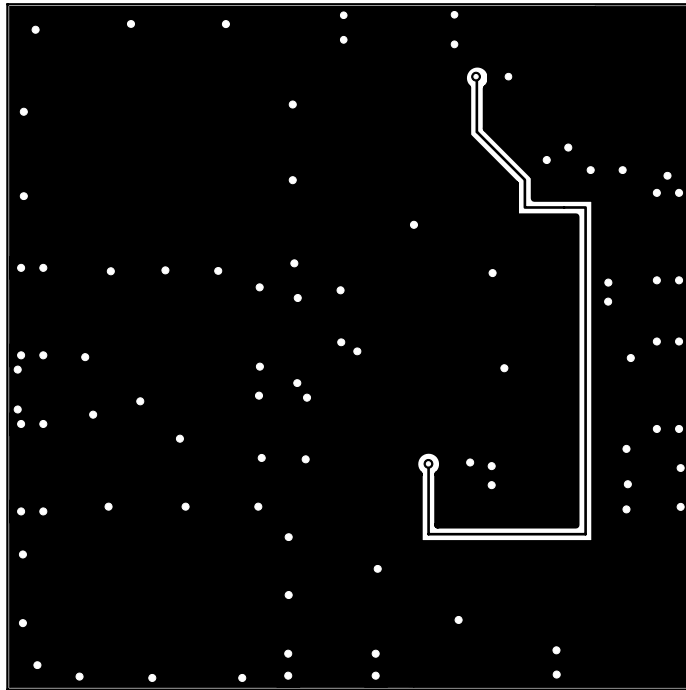

RF2667

CDMA Cascade Conversion Gain versus Gain Control
Gain Control Voltage ($V_{CC}=3.0V$, 85MHz)

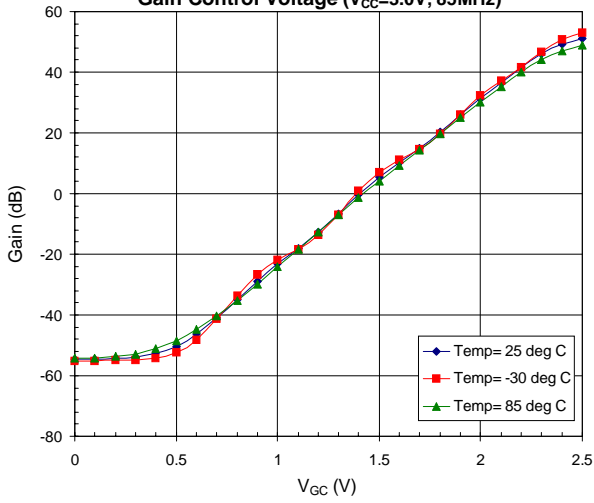

CDMA OIP3 versus Gain
($V_{CC}=3.0V$, 85 MHz)

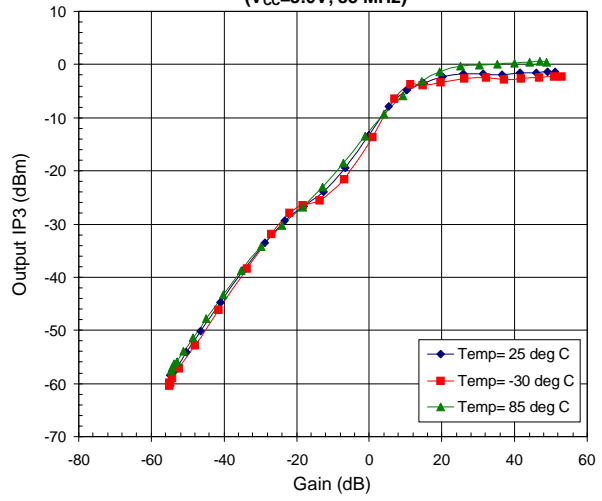

CDMA IIP3 versus Gain
($V_{CC}=3.0V$, 85 MHz)

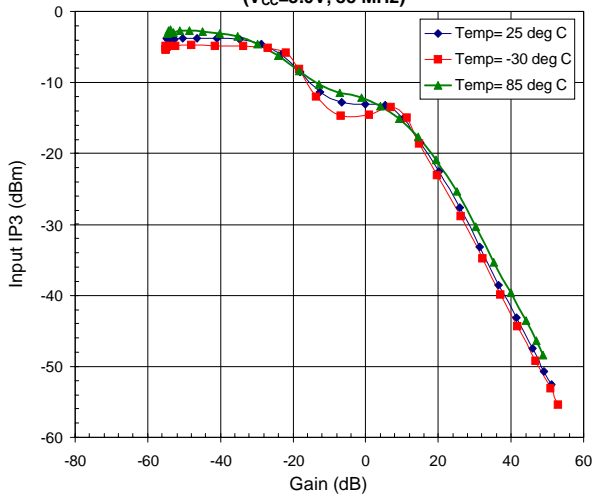

7

QUADRATURE
DEMODULATORS