



# RF3166D

DUAL-BAND GSM900/DCS  
POWER AMP MODULE

## Typical Applications

- 3V Dual-Band GSM Handsets
- Commercial and Consumer Systems
- Portable Battery-Powered Equipment
- EGSM900/DCS Products
- GPRS Class 12
- Power Star™ Module

## Product Description

The RF3166 is a high-power, high-efficiency power amplifier module with integrated power control that provides over 50dB of control range. The device is a self-contained 6mmx6mm module with 50Ω input and output terminals. The device is designed for use as the final RF amplifier in EGSM900 and DCS handheld digital cellular equipment and other applications in the 880MHz to 915MHz and 1710MHz to 1785MHz bands. The RF3166 incorporates RFMD's latest  $V_{BATT}$  tracking circuit, which monitors battery voltage and prevents the power control loop from reaching saturation. The  $V_{BATT}$  tracking circuit eliminates the need to monitor battery voltage, thereby minimizing switching transients. The RF3166 requires no external routing or external components, simplifying layout and reducing board space.

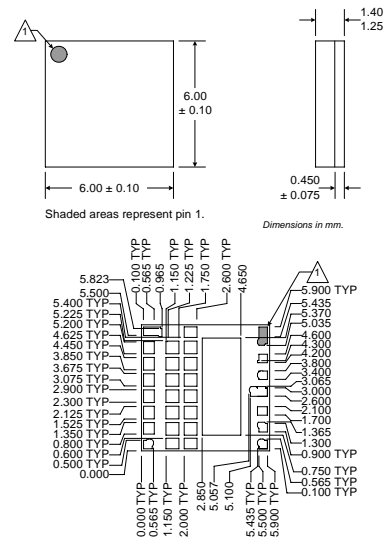

## Optimum Technology Matching® Applied

- |                                     |  |   |
|-------------------------------------|--|---|
| <input type="checkbox"/> Si BJT     | <input checked="" type="checkbox"/> GaAs HBT | <input type="checkbox"/> GaAs MESFET        |
| <input type="checkbox"/> Si Bi-CMOS | <input type="checkbox"/> SiGe HBT            | <input checked="" type="checkbox"/> Si CMOS |
| <input type="checkbox"/> InGaP/HBT  | <input type="checkbox"/> GaN HEMT            | <input type="checkbox"/> SiGe Bi-CMOS       |

Package Style: Module, 6mm x 6mm

## Features

- Ultra-Small 6mmx6mm Package Size
- Integrated  $V_{REG}$
- Complete Power Control Solution
- Automatic  $V_{BATT}$  Tracking Circuit
- No External Components or Routing
- Improved Power Flatness

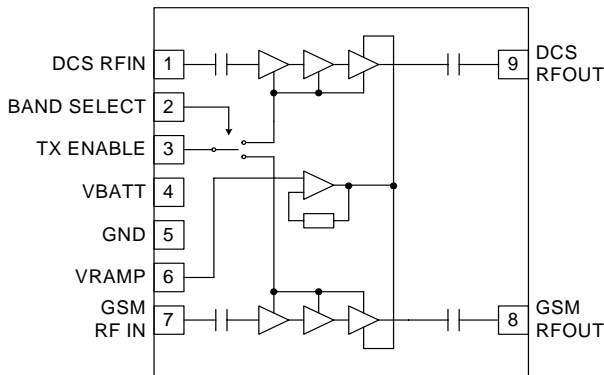

Functional Block Diagram

## Ordering Information

RF3166D Dual-Band GSM900/DCS Power Amp Module  
 RF3166D SB Power Amp Module 5-Piece Sample Pack  
 RF3166DPCBA-410 Fully Assembled Evaluation Board

RF Micro Devices, Inc.  
 7628 Thorndike Road  
 Greensboro, NC 27409, USA

Tel (336) 664 1233  
 Fax (336) 664 0454  
<http://www.rfmd.com>

# RF3166D

## Absolute Maximum Ratings

Parameter	Rating	Unit
Supply Voltage	-0.3 to +6.0	V <sub>DC</sub>
Power Control Voltage (V <sub>RAMP</sub> )	-0.3 to +2.2	V
Input RF Power	+10	dBm
Max Duty Cycle	50	%
Output Load VSWR	10:1	
Operating Case Temperature	-20 to +85	°C
Storage Temperature	-55 to +150	°C



**Caution!** ESD sensitive device.

RF Micro Devices believes the furnished information is correct and accurate at the time of this printing. However, RF Micro Devices reserves the right to make changes to its products without notice. RF Micro Devices does not assume responsibility for the use of the described product(s).

Parameter	Specification			Unit	Condition
	Min.	Typ.	Max.		
<b>Overall Power Control</b>					
<b>V<sub>RAMP</sub></b>					
Power Control "ON"			2.1	V	Max. P <sub>OUT</sub> , Voltage supplied to the input
Power Control "OFF"		0.26		V	Min. P <sub>OUT</sub> , Voltage supplied to the input
V <sub>RAMP</sub> Input Capacitance		2	20	pF	DC to 2MHz
V <sub>RAMP</sub> Input Current			30	μA	V <sub>RAMP</sub> =2.1V
TX Enable "ON"	1.5			V	
TX Enable "OFF"			0.5	V	
GSM Band Enable			0.5	V	
DCS/PCS Band Enable	1.5			V	
<b>Overall Power Supply</b>					
Power Supply Voltage		3.5		V	Specifications
	3.0		4.5	V	Nominal operating limits
	4.5		5.5	V	V <sub>RAMP</sub> <1.7V
Power Supply Current		1		μA	P <sub>IN</sub> <-30dBm, TX Enable=Low,
			150	mA	Temp=-20°C to +85°C
					V <sub>RAMP</sub> =0.26V, TX Enable=High
<b>Overall Control Signals</b>					
Band Select "Low"	0	0	0.5	V	
Band Select "High"	1.5	2.0	3.0	V	
Band Select "High" Current		20	50	μA	
TX Enable "Low"	0	0	0.5	V	
TX Enable "High"	1.5	2.0	3.0	V	
TX Enable "High" Current		1	2	μA	

Parameter	Specification			Unit	Condition
	Min.	Typ.	Max.		
<b>Overall (GSM900 Mode)</b>					Temp=+25 °C, V <sub>BATT</sub> =3.5V, V <sub>RAMP</sub> =2.1V, P <sub>IN</sub> =3dBm, Freq=880MHz to 915MHz, 25% Duty Cycle, Pulse Width=1154µs
Operating Frequency Range		880 to 915		MHz	
Maximum Output Power 1	33.7			dBm	Temp=+25°C, V <sub>BATT</sub> =3.5V, V <sub>RAMP</sub> =2.1V
Total Efficiency	46			%	At P <sub>OUT MAX</sub> , V <sub>BATT</sub> =3.5V
Input Power Range	0	+3	+5	dBm	Maximum output power guaranteed at minimum drive level
Output Noise Power		-83	-80	dBm	RBW=100kHz, 925MHz to 935MHz, P <sub>OUT</sub> ≤ +33.7dBm
		-85	-83	dBm	RBW=100kHz, 935MHz to 960MHz, P <sub>OUT</sub> ≤ +33.7dBm
Forward Isolation 1		-40	-30	dBm	TXEnable=Low, P <sub>IN</sub> =+5dBm
Forward Isolation 2		-30	-10	dBm	TXEnable=High, P <sub>IN</sub> =+5dBm, V <sub>RAMP</sub> =0.26V
Cross Band Isolation 2f <sub>0</sub>		-30	-20	dBm	V <sub>RAMP</sub> =0.26V to V <sub>RAMP_RP</sub>
Second Harmonic		-15	-10	dBm	V <sub>RAMP</sub> =0.26V to V <sub>RAMP_RP</sub>
Third Harmonic		-30	-15	dBm	V <sub>RAMP</sub> =0.26V to V <sub>RAMP_RP</sub>
All Other Non-Harmonic Spurious			-36	dBm	V <sub>RAMP</sub> =0.26V to 2.1V
Input Impedance		50		Ω	
Input VSWR			2.5:1		
Output Load VSWR Stability	8:1				Spurious<-36dBm, RBW=3MHz Set V <sub>RAMP</sub> where P <sub>OUT</sub> ≤33.7dBm into 50Ω load
Output Load VSWR Ruggedness	10:1				Set V <sub>RAMP</sub> where P <sub>OUT</sub> ≤33.7dBm into 50Ω load. No damage or permanent degradation to part.
Output Load Impedance		50		Ω	Load impedance presented at RF OUT pad
<b>Power Control V<sub>RAMP</sub></b>					
Power Control Range	50	55		dB	V <sub>RAMP</sub> =0.26V to 2.1V
Transient Spectrum		-35		dBm	V <sub>RAMP</sub> =V <sub>RAMP_RP</sub>
Transient Spectrum Under Extreme Conditions			-23	dBm	Temp=-20°C to +85°C, V <sub>BATT</sub> ≥3.0V. Ramping shape same as for Condition: Temp=25°C, V <sub>BATT</sub> =3.5V, V <sub>RAMP</sub> =V <sub>RAMP_RP</sub>

Notes:

V<sub>RAMP\_RP</sub>=V<sub>RAMP</sub> set for 33.7dBm at nominal conditions.

# RF3166D

Parameter	Specification			Unit	Condition
	Min.	Typ.	Max.		
<b>Overall (DCS Mode)</b>					Temp=25°C, V <sub>BATT</sub> =3.5V, V <sub>RAMP</sub> =2.1V, P <sub>IN</sub> =3dBm, Freq=1710MHz to 1785MHz, 25% Duty Cycle, pulse width=1154µs
Operating Frequency Range		1710 to 1785		MHz	
Maximum Output Power 1	31.5			dBm	Temp=+25°C, V <sub>BATT</sub> =3.5V, V <sub>RAMP</sub> =2.1V
Total Efficiency	44			%	At P <sub>OUT MAX</sub> , V <sub>BATT</sub> =3.5V
Input Power Range	0	+3	+5	dBm	Maximum output power guaranteed at minimum drive level
Output Noise Power		-85	-80	dBm	RBW=100kHz, 1805MHz to 1880MHz, P <sub>OUT</sub> ≤ 31.5dBm
Forward Isolation 1		-40	-30	dBm	TXEnable=Low, P <sub>IN</sub> =+5dBm
Forward Isolation 2		-25	-10	dBm	TXEnable=High, V <sub>RAMP</sub> =0.26V, P <sub>IN</sub> =+5dBm
Second Harmonic		-15	-7	dBm	V <sub>RAMP</sub> =0.26V to V <sub>RAMP_RP</sub>
Third Harmonic		-30	-15	dBm	V <sub>RAMP</sub> =0.26V to V <sub>RAMP_RP</sub>
All Other Non-Harmonic Spurious			-36	dBm	V <sub>RAMP</sub> =0.26V to 2.1V
Input Impedance		50		Ω	
Input VSWR			2.5:1		
Output Load VSWR Stability	8:1				Spurious<-36dBm, RBW=3MHz Set V <sub>RAMP</sub> where P <sub>OUT</sub> ≤31.5dBm into 50Ω load
Output Load VSWR Ruggedness	10:1				Set V <sub>RAMP</sub> where P <sub>OUT</sub> ≤31.5dBm into 50Ω load. No damage or permanent degradation to part.
Output Load Impedance		50		Ω	Load impedance presented at RF OUT pad
<b>Power Control V<sub>RAMP</sub></b>					
Power Control Range	45	50		dB	V <sub>RAMP</sub> =0.26V to 2.1V
Transient Spectrum		-35		dBm	V <sub>RAMP</sub> =V <sub>RAMP_RP</sub>
Transient Spectrum Under Extreme Conditions			-23	dBm	Temp=-20°C to +85°C, V <sub>BATT</sub> ≥3.0V. Ramping shape same as for Condition: Temp=25°C, V <sub>BATT</sub> =3.5V, V <sub>RAMP</sub> =V <sub>RAMP_RP</sub>

Notes:

V<sub>RAMP\_RP</sub>=V<sub>RAMP</sub> set for 31.5dBm at nominal conditions.

# RF3166D

Pin	Function	Description	Interface Schematic
1	<b>DCS IN</b>	RF input to the DCS band. This is a 50Ω input.	
2	<b>BAND SELECT</b>	Allows external control to select the GSM or DCS band with a logic high or low. A logic low enables the GSM band whereas a logic high enables the DCS band.	
3	<b>TX ENABLE</b>	This signal enables the PA module for operation with a logic high.	
4	<b>VBATT</b>	Power supply for the module. This should be connected to the battery.	
5	<b>GND</b>		
6	<b>VRAMP</b>	Ramping signal from DAC. A 300kHz lowpass filter is integrated into the CMOS. No external filtering is required.	
7	<b>GSM IN</b>	RF input to the GSM band. This is a 50Ω input.	
8	<b>GSM OUT</b>	RF output for the GSM band. This is a 50Ω output. The output load line matching is contained internal to the package.	
9	<b>DCS/PCS OUT</b>	RF output for the DCS band. This is a 50Ω output. The output load line matching is contained internal to the package.	
<b>Pkg Base</b>	<b>GND</b>		

# RF3166D

## Pin Out Top Down View

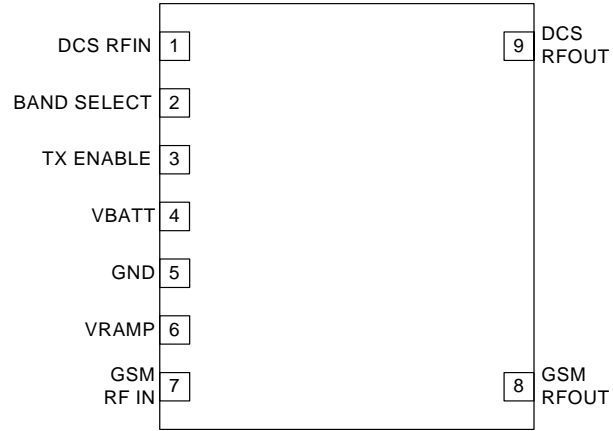

## Application Schematic

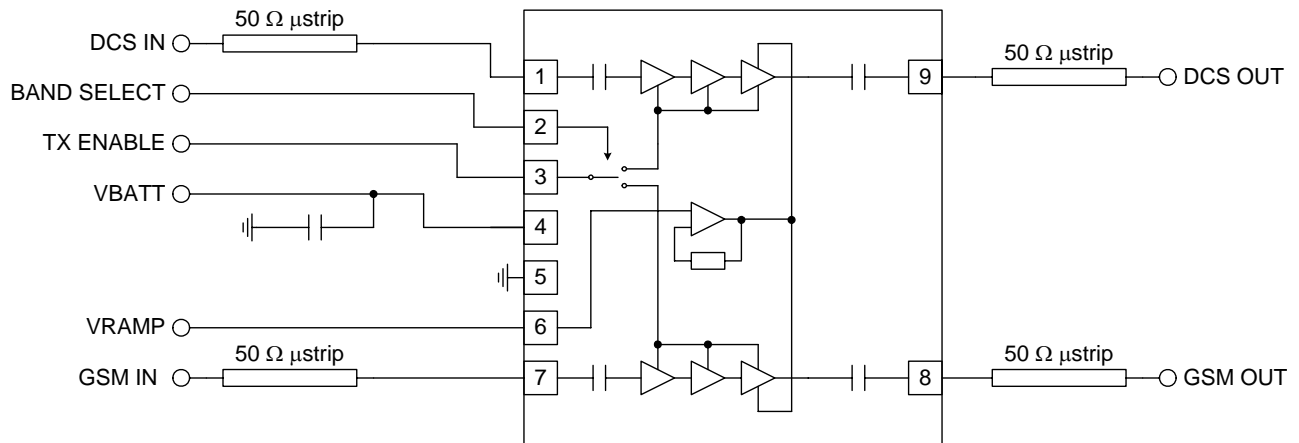

## Evaluation Board Schematic

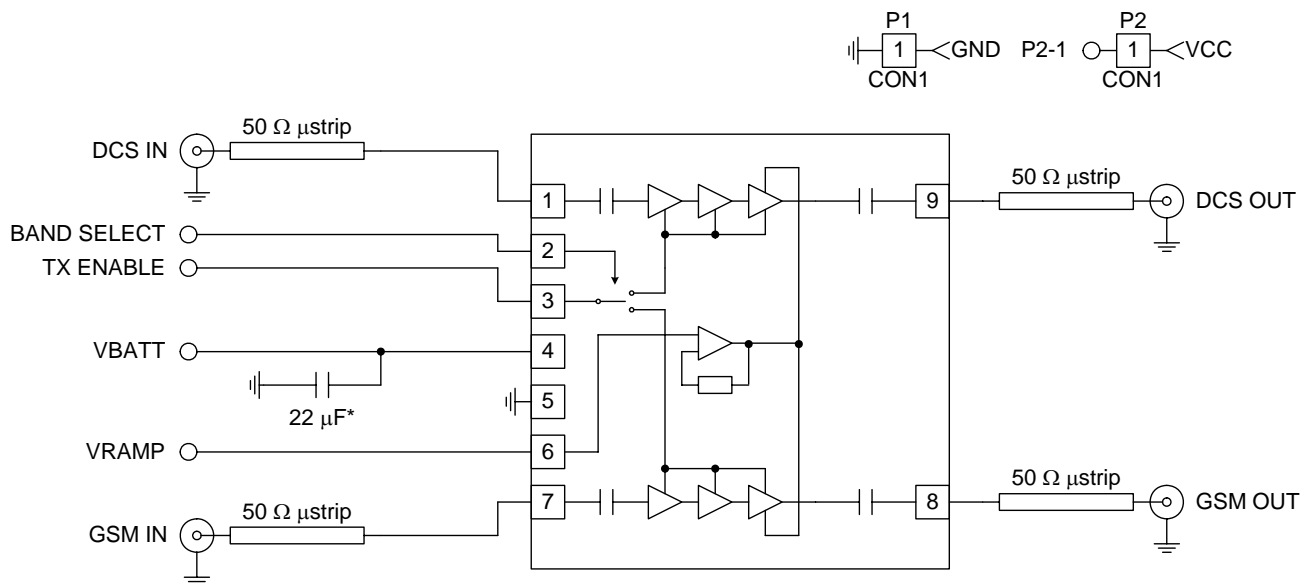

### Notes:

- \* The value of  $V_{BATT}$  decoupling capacitor depends on the noise level of the phone board. Capacitor type may be either tantalum or ceramic. Some applications may not require this capacitor.
- 1. All the PA output measurements are referenced to the PA output pad (pins 8 and 9).
- 2. The 50 Ω  $\mu$ strip between the PA output pad and the SMA connector has an approximate insertion loss of 0.1 dB for EGSM900 and 0.2 dB for DCS1800 bands.

# RF3166D

## Evaluation Board Layout Board Size 2.0" x 2.0"

Board Thickness 0.032", Board Material FR-4, Multi-Layer

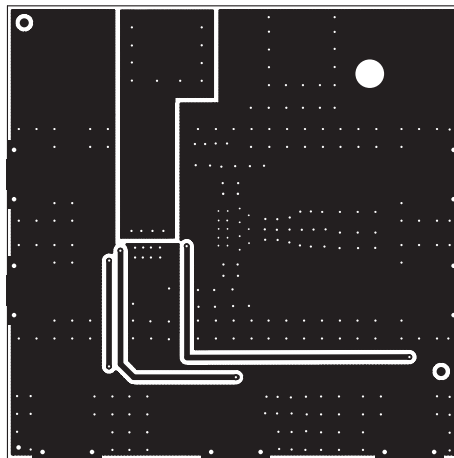
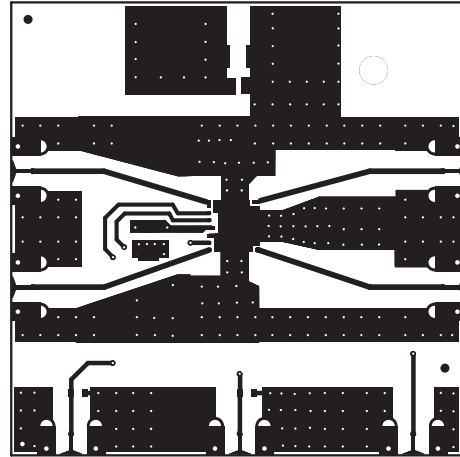
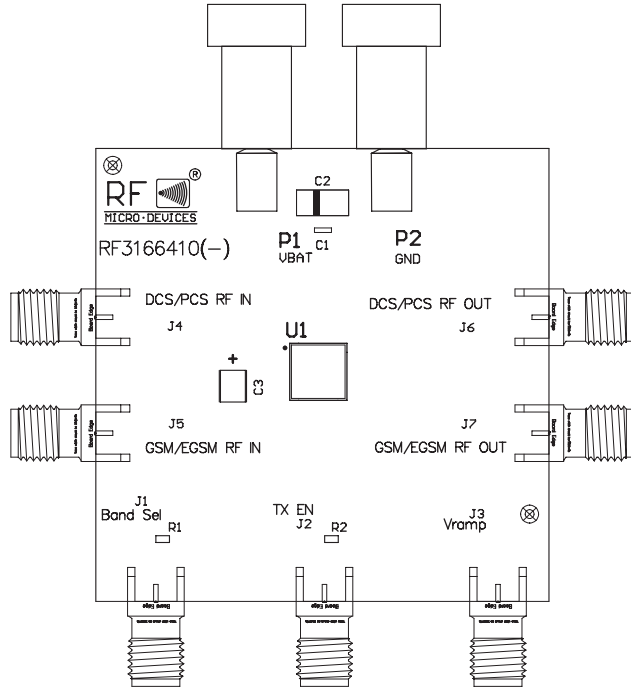



## Theory of Operation

### Overview

The RF3166 is a dual-band EGSM900 and DCS1800 power amplifier module that incorporates an indirect closed loop method of power control. This simplifies the phone design by eliminating the need for the complicated control loop design. The indirect closed loop appears as an open loop to the user and can be driven directly from the DAC output in the baseband circuit.

### Theory of Operation

The indirect closed loop is essentially a closed loop method of power control that is invisible to the user. Most power control systems in GSM sense either forward power or collector/drain current. The RF3166 does not use a power detector. A high-speed control loop is incorporated to regulate the collector voltage of the amplifier while the stage are held at a constant bias. The  $V_{RAMP}$  signal is multiplied by a factor of 2.3 and the collector voltage for all three stages is regulated to the multiplied  $V_{RAMP}$  voltage. The basic circuit is shown in the following diagram.

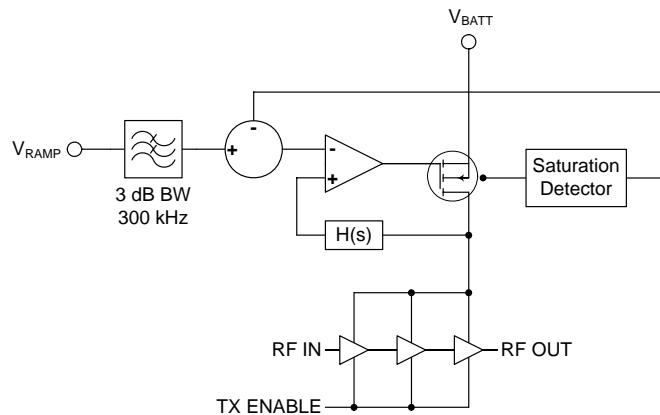

By regulating the power, the stages are held in saturation across all power levels. As the required output power is decreased from full power down to 0dBm, the collector voltage is also decreased. This regulation of output power is demonstrated in Equation 1 where the relationship between collector voltage and output power is shown. Although load impedance affects output power, supply fluctuations are the dominate mode of power variations. With the RF3166 regulating collector voltage, the dominant mode of power fluctuations is eliminated.

$$P_{dBm} = 10 \cdot \log \left[ \frac{(2 \cdot V_{CC} - V_{SAT})^2}{8 \cdot R_{LOAD} \cdot 10^{-3}} \right] \quad (\text{Eq. 1})$$

There are several key factors to consider in the implementation of a transmitter solution for a mobile phone. Some of them are:

- Current draw and system efficiency
- Power variation due to Supply Voltage
- Power variation due to frequency
- Power variation due to temperature
- Input impedance variation
- Noise power
- Loop stability
- Loop bandwidth variations across power levels
- Burst timing and transient spectrum trade offs
- Harmonics

# RF3166D

Output power does not vary due to supply voltage under normal operating conditions if  $V_{RAMP}$  is sufficiently lower than  $V_{BATT}$ . By regulating the collector voltage to the PA the voltage sensitivity is essentially eliminated. This covers most cases where the PA will be operated. However, as the battery discharges and approaches its lower power range the maximum output power from the PA will also drop slightly. In this case it is important to also decrease  $V_{RAMP}$  to prevent the power control from inducing switching transients. These transients occur as a result of the control loop slowing down and not regulating power in accordance with  $V_{RAMP}$ .

The switching transients due to low battery conditions are regulated by the  $V_{BATT}$  tracking circuit. The  $V_{BATT}$  tracking circuit consists of a feedback loop that detects FET saturation. As the FET approaches saturation, the limiter adjusts the  $V_{RAMP}$  voltage in order to ensure minimum switching transients. The  $V_{BATT}$  tracking circuit is integrated into the CMOS controller and requires no additional input from the user.

Due to reactive output matches, there are output power variations across frequency. There are a number of components that can make the effects greater or less. Power variation straight out of the RF3166 is shown in the tables below.

The components following the power amplifier often have insertion loss variation with respect to frequency. Usually, there is some length of microstrip that follows the power amplifier. There is also a frequency response found in directional couplers due to variation in the coupling factor over frequency, as well as the sensitivity of the detector diode. Since the RF3166 does not use a directional coupler with a diode detector, these variations do not occur.

Input impedance variation is found in most GSM power amplifiers. This is due to a device phenomena where  $C_{BE}$  and  $C_{CB}$  ( $C_{GS}$  and  $C_{SG}$  for a FET) vary over the bias voltage. The same principle used to make varactors is present in the power amplifiers. The junction capacitance is a function of the bias across the junction. This produces input impedance variations as the  $V_{apc}$  voltage is swept. Although this could present a problem with frequency pulling the transmit VCO off frequency, most synthesizer designers use very wide loop bandwidths to quickly compensate for frequency variations due to the load variations presented to the VCO.

The RF3166 presents a very constant load to the VCO. This is because all stages of the RF3166 are run at constant bias. As a result, there is constant reactance at the base emitter and base collector junction of the input stage to the power amplifier.

Noise power in PA's where output power is controlled by changing the bias voltage is often a problem when backing off of output power. The reason is that the gain is changed in all stages and according to the noise formula (Equation 2),

$$F_{TOT} = F1 + \frac{F2 - 1}{G1} + \frac{F3 - 1}{G1 \cdot G2} \quad (\text{Eq. 2})$$

the noise figure depends on noise factor and gain in all stages. Because the bias point of the RF3166 is kept constant the gain in the first stage is always high and the overall noise power is not increased when decreasing output power.

Power control loop stability often presents many challenges to transmitter design. Designing a proper power control loop involves trade-offs affecting stability, transient spectrum and burst timing.

In conventional architectures the PA gain (dB/V) varies across different power levels, and as a result the loop bandwidth also varies. With some power amplifiers it is possible for the PA gain (control slope) to change from 100dB/V to as high as 1000dB/V. The challenge in this scenario is keeping the loop bandwidth wide enough to meet the burst mask at low slope regions which often causes instability at high slope regions.

The RF3166 loop bandwidth is determined by internal bandwidth and the RF output load and does not change with respect to power levels. This makes it easier to maintain loop stability with a high bandwidth loop since the bias voltage and collector voltage do not vary.

An often overlooked problem in PA control loops is that a delay not only decreases loop stability it also affects the burst timing when, for instance the input power from the VCO decreases (or increases) with respect to temperature or supply voltage. The burst timing then appears to shift to the right especially at low power levels. The RF3166 is insensitive to a change in input power and the burst timing is constant and requires no software compensation.

Switching transients occur when the up and down ramp of the burst is not smooth enough or suddenly changes shape. If the control slope of a PA has an inflection point within the output power range or if the slope is simply too steep it is difficult to prevent switching transients. Controlling the output power by changing the collector voltage is as earlier described based on the physical relationship between voltage swing and output power. Furthermore all stages are kept constantly biased so inflection points are nonexistent.

Harmonics are natural products of high efficiency power amplifier design. An ideal class "E" saturated power amplifier will produce a perfect square wave. Looking at the Fourier transform of a square wave reveals high harmonic content. Although this is common to all power amplifiers, there are other factors that contribute to conducted harmonic content as well. With most power control methods a peak power diode detector is used to rectify and sense forward power. Through the rectification process there is additional squaring of the waveform resulting in higher harmonics. The RF3166 address this by eliminating the need for the detector diode. Therefore the harmonics coming out of the PA should represent the maximum power of the harmonics throughout the transmit chain. This is based upon proper harmonic termination of the transmit port. The receive port termination on the T/R switch as well as the harmonic impedance from the switch itself will have an impact on harmonics. Should a problem arise, these terminations should be explored.

# RF3166D

## PCB Design Requirements

### PCB Surface Finish

The PCB surface finish used for RFMD's qualification process is electroless nickel, immersion gold. Typical thickness is 3µinch to 8µinch gold over 180µinch nickel.

### PCB Land Pattern Recommendation

PCB land patterns are based on IPC-SM-782 standards when possible. The pad pattern shown has been developed and tested for optimized assembly at RFMD; however, it may require some modifications to address company specific assembly processes. The PCB land pattern has been developed to accommodate lead and package tolerances.

### PCB Metal Land Pattern

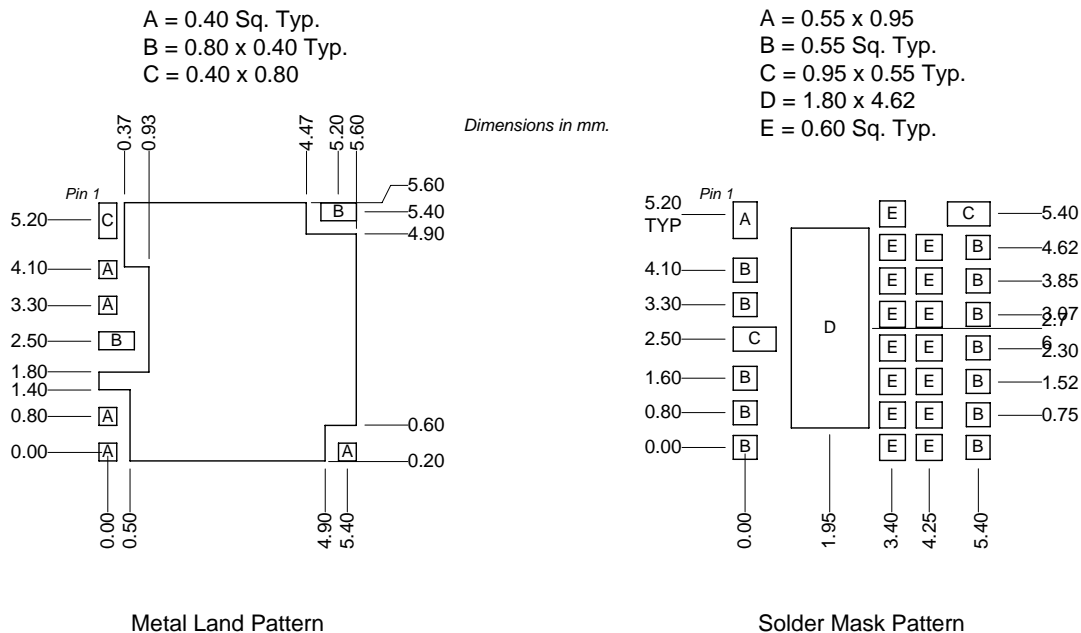

Figure 1. PCB Metal Land and Solder Mask Patterns (Top View)

### PCB Solder Mask Pattern

Liquid Photo-Imageable (LPI) solder mask is recommended. The solder mask footprint will match what is shown for the PCB metal land pattern with a 2mil to 3mil expansion to accommodate solder mask registration clearance around all pads. The center-grounding pad shall also have a solder mask clearance. Expansion of the pads to create solder mask clearance can be provided in the master data or requested from the PCB fabrication supplier.

### Thermal Pad and Via Design

Thermal vias are required in the PCB layout to effectively conduct heat away from the package. The via pattern has been designed to address thermal, power dissipation and electrical requirements of the device as well as accommodating routing strategies.

The via pattern used for the RFMD qualification is based on thru-hole vias with 0.203mm to 0.330mm finished hole size on a 0.5mm to 1.2mm grid pattern with 0.025mm plating on via walls. If micro vias are used in a design, it is suggested that the quantity of vias be increased by a 4:1 ratio to achieve similar results.