

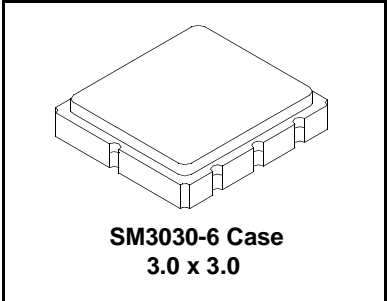

RF3336E

868.35 MHz SAW Filter



- **Front-End Filter for European Wireless Receivers**
- **Low-Loss, Coupled-resonator Quartz Design**
- **Simple External Impedance Matching**
- **Complies with Directive 2002/95/EC (RoHS)**



The RF3336E is a low-loss, compact, and economical surface-acoustic-wave (SAW) filter designed to provide front-end selectivity in 868.35 MHz receivers. Receivers using this filter include superheterodynes with 10.7 MHz or 500 kHz IFs, direct conversion receivers and superregenerative receivers. Typical applications of these receivers include wireless remote-control and security devices operating in Europe under ETSI I-ETS 300 220. This coupled-resonator filter (CRF) uses selective null placement to provide suppression, typically greater than 40 dB, of the LO and image spurious responses of superhet receivers with 10.7 MHz IF. RFM's advanced SAW design and fabrication technology is utilized to achieve high performance and very low loss with simple external impedance matching.

Electrical Characteristics

| Characteristic | Sym | Notes | Minimum | Typical | Maximum | Units |
|--|---------------------------------------|---------|-------------------|---------|------------------------|---------------------|
| Center Frequency @ 25°C Absolute Frequency | f_C | 1, 2, 3 | | 868.35 | | MHz |
| Insertion Loss | IL | 1, 3 | | 2.5 | 4.0 | dB |
| 3 dB Bandwidth | BW_3 | 1, 2, 3 | 500 | 650 | 900 | kHz |
| Attenuation: (relative to ILmin) | | 1, 3 | 10 - 700 MHz | 50 | 55 | dB |
| | | | 700 - 830 MHz | 40 | 45 | |
| | | | 830 - 850 MHz | 35 | 40 | |
| | | | 850 - 864.4 MHz | 20 | 25 | |
| | | | 870.4 - 877.4 MHz | 21 | 26 | |
| | | | 877.4 - 882.4 MHz | 15 | 19 | |
| | | | 882.4 - 900 MHz | 28 | 35 | |
| 900 - 1000 MHz | 40 | 45 | | | | |
| Temperature Freq. Temp. Coefficient | FTC | 3, 4 | | 0.032 | | ppm/°C ² |
| Frequency Aging Absolute Value during the First Year | fA | 5 | | <±10 | | ppm/yr |
| Impedance @ f_C | $Z_{IN} = R_{IN} \parallel C_{IN}$ | 1 | Z_{IN} | | 55 Ω 23.9 pF | |
| | $Z_{OUT} = R_{OUT} \parallel C_{OUT}$ | | Z_{OUT} | | 53 Ω 20.2 pF | |
| Lid Symbolization (in addition to Lot and/or Date Codes) | 700 YWWS | | | | | |
| Standard Reel Quantity | Reel Size 7 Inch | 9 | | | 500 Pieces/Reel | |
| | Reel Size 13 Inch | | | | 3000 Pieces/Reel | |



CAUTION: Electrostatic Sensitive Device. Observe precautions for handling.

Notes:

1. Unless noted otherwise, all measurements are made with the filter installed in the specified test fixture which is connected to a 50 Ω test system with VSWR \leq 1.2:1. The test fixture L and C are adjusted for minimum insertion loss at the filter center frequency, f_C . Note that insertion loss and bandwidth and passband shape are dependent on the impedance matching component values and quality.
2. The frequency f_C is defined as the midpoint between the 3dB frequencies.
3. Where noted specifications apply over the entire specified operating temperature range of -40 to 90°C.
4. The turnover temperature, T_O , is the temperature of maximum (or turnover) frequency, f_O . The nominal frequency at any case temperature, T_C , may be calculated from: $f = f_O [1 - FTC (T_O - T_C)^2]$.
5. Frequency aging is the change in f_C with time and is specified at +65°C or less. Aging may exceed the specification for prolonged temperatures above +65°C. Typically, aging is greatest the first year after manufacture, decreasing significantly in subsequent years.
6. The design, manufacturing process, and specifications of this device are subject to change.
7. One or more of the following U.S. Patents apply: 4,54,488, 4,616,197, and others pending.
8. All equipment designs utilizing this product must be approved by the appropriate government agency prior to manufacture or sale.
9. Tape and Reel Standard for ANSI / EIA 481.

Frequency Response Plots

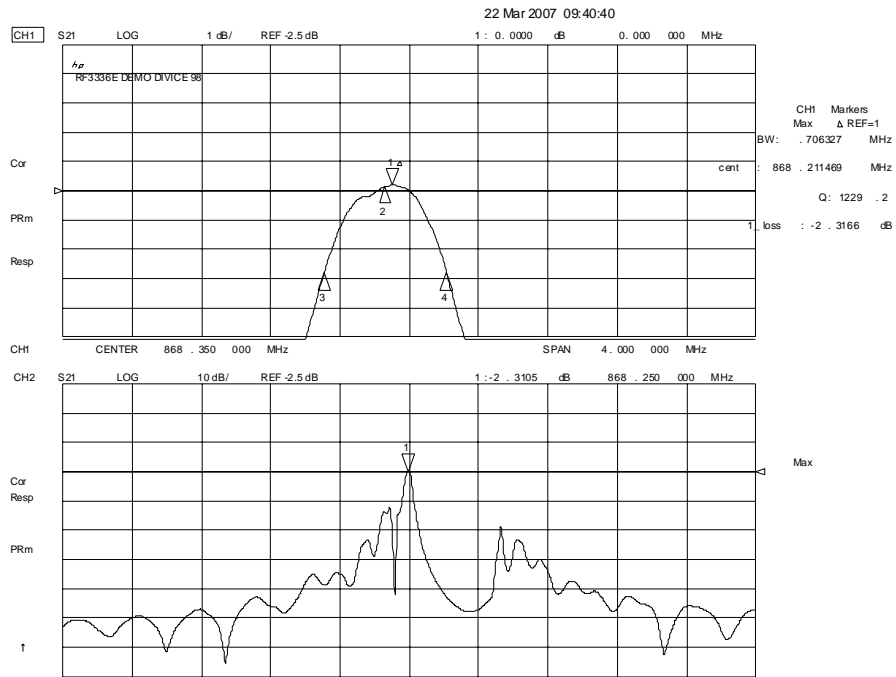

Impedance Plots

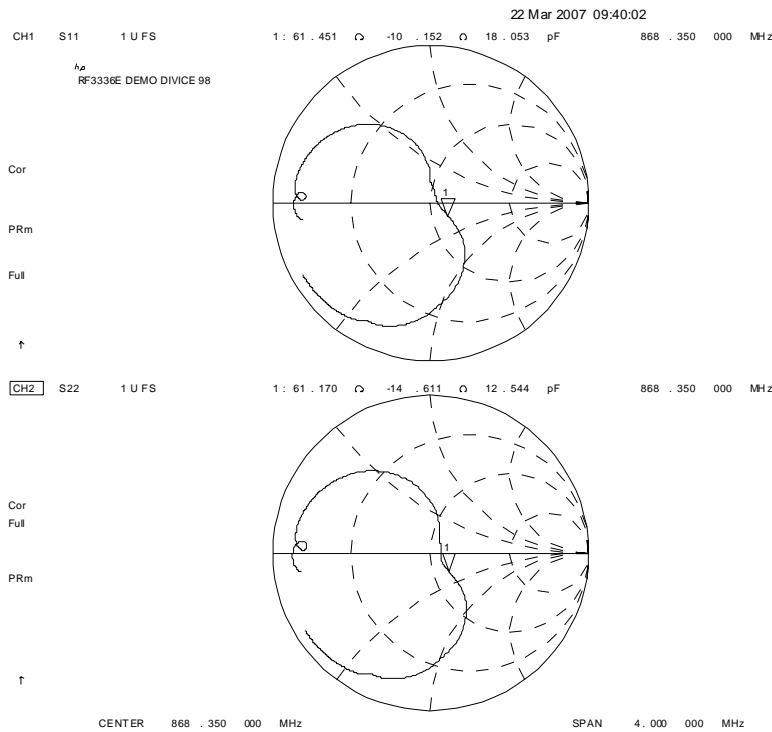

Absolute Maximum Ratings

| Rating | Value | Units |
|--|-------------|-------|
| Input Power Level | 10 | dBm |
| DC Voltage on any non-ground Terminal | 12 | VDC |
| Storage Temperature | -40 to +125 | °C |
| Operable Temperature Range | -40 to +125 | °C |
| Soldering Temperature (10 seconds / 5 cycles Max.) | 260 | °C |

Electrical Connections

| Pin | Connection |
|-----|---------------|
| 1 | Input Ground |
| 2 | Input |
| 3 | Case Ground |
| 4 | Output Ground |
| 5 | Output |
| 6 | Ground |

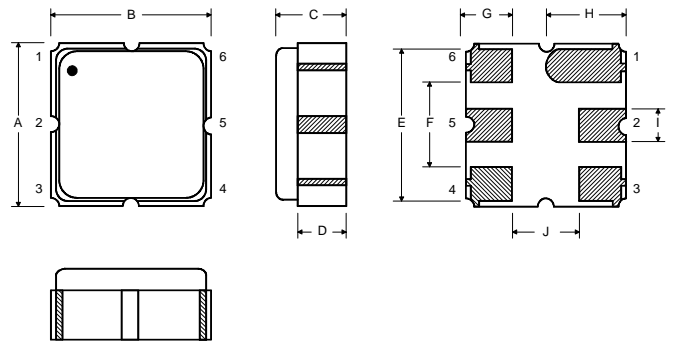

Case Dimensions

| Dimension | mm | | | Inches | | |
|-----------|------|------|------|--------|-------|-------|
| | Min | Nom | Max | Min | Nom | Max |
| A | 2.87 | 3.0 | 3.13 | 0.113 | 0.118 | 0.123 |
| B | 2.87 | 3.0 | 3.13 | 0.113 | 0.118 | 0.123 |
| C | 1.12 | 1.25 | 1.38 | 0.044 | 0.049 | 0.054 |
| D | 0.77 | 0.90 | 1.03 | 0.030 | 0.035 | 0.040 |
| E | 2.67 | 2.80 | 2.93 | 0.105 | 0.110 | 0.115 |
| F | 1.47 | 1.6 | 1.73 | 0.058 | 0.063 | 0.068 |
| G | 0.72 | 0.85 | 0.98 | 0.028 | 0.033 | 0.038 |
| H | 1.37 | 1.5 | 1.63 | 0.054 | 0.059 | 0.064 |
| I | 0.47 | 0.60 | 0.73 | 0.019 | 0.024 | 0.029 |
| J | 1.17 | 1.30 | 1.43 | 0.046 | 0.051 | 0.056 |

Matching Circuit to 50Ω

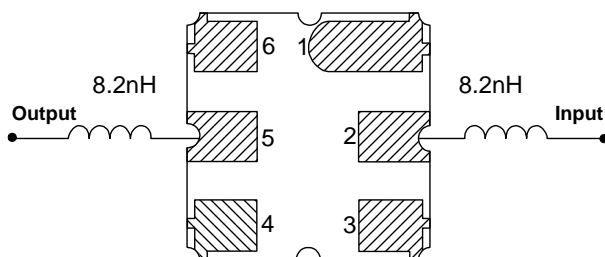

Optional

Electrical Connections

| Pin | Connection |
|-----|---------------|
| 1 | Input |
| 2 | Input Ground |
| 3 | Case Ground |
| 4 | Output |
| 5 | Output Ground |
| 6 | Ground |

Matching Circuit to 50Ω

