



RF5111

3V DCS POWER AMPLIFIER

RoHS Compliant & Pb-Free Product

Typical Applications

- 3V DCS1800 (PCN) Cellular Handsets
- 3V DCS1900 (PCS) Cellular Handsets
- 3V Dual-Band/Triple-Band Handsets
- Commercial and Consumer Systems
- Portable Battery-Powered Equipment
- GPRS Compatible

Product Description

The RF5111 is a high-power, high-efficiency power amplifier module offering high performance in GSM or GPRS applications. The device is manufactured on an advanced GaAs HBT process, and has been designed for use as the final RF amplifier in DCS1800/1900 handheld digital cellular equipment and other applications in the 1700MHz to 2000MHz band. On-board power control provides over 65dB of control range with an analog voltage input, and provides power down with a logic "low" for standby operation. The device is self-contained with 50Ω input and the output can be easily matched to obtain optimum power and efficiency characteristics. The RF5111 can be used together with the RF5110 for dual-band operation. The device is packaged in an ultra-small plastic package, minimizing the required board space.

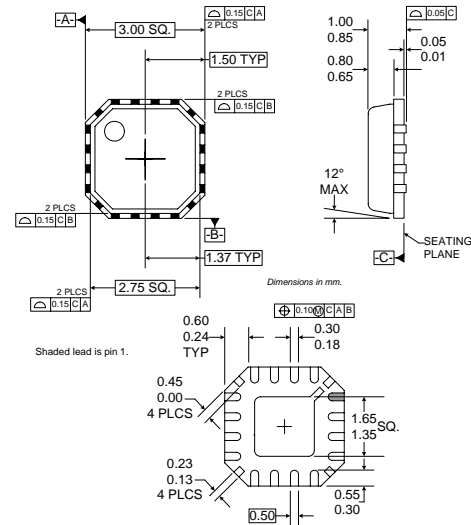

Optimum Technology Matching® Applied

- | | | |
|-------------------------------------|--|---------------------------------------|
| <input type="checkbox"/> Si BJT | <input checked="" type="checkbox"/> GaAs HBT | <input type="checkbox"/> GaAs MESFET |
| <input type="checkbox"/> Si Bi-CMOS | <input type="checkbox"/> SiGe HBT | <input type="checkbox"/> Si CMOS |
| <input type="checkbox"/> InGaP/HBT | <input type="checkbox"/> GaN HEMT | <input type="checkbox"/> SiGe Bi-CMOS |

Package Style: QFN, 16-Pin, 3x3

Features

- Single 2.7V to 4.8V Supply Voltage
- +33dBm Output Power at 3.5V
- 27dB Gain with Analog Gain Control
- 50% Efficiency
- 1700MHz to 1950MHz Operation
- Supports DCS1800 and PCS1900

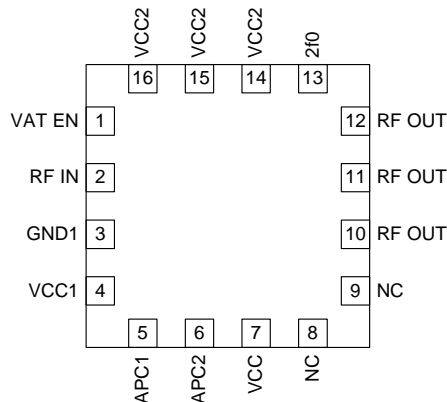

Functional Block Diagram

Ordering Information

RF5111 3V DCS Power Amplifier
 RF5111PCBA-41X Fully Assembled Evaluation Board

RF Micro Devices, Inc.
 7628 Thorndike Road
 Greensboro, NC 27409, USA

Tel (336) 664 1233
 Fax (336) 664 0454
<http://www.rfmd.com>

RF5111

Absolute Maximum Ratings

Parameter	Rating	Unit
Supply Voltage	-0.5 to +6.0	V _{DC}
Power Control Voltage (V _{APC})	-0.5 to +3.0	V
Enable Voltage (V _{AT_EN})	-0.5 to +3.0	V
DC Supply Current	1500	mA
Input RF Power	+13	dBm
Duty Cycle at Max Power	50	%
Output Load VSWR	10:1	
Operating Case Temperature	-40 to +85	°C
Storage Temperature	-55 to +150	°C



Caution! ESD sensitive device.

RF Micro Devices believes the furnished information is correct and accurate at the time of this printing. RoHS marking based on EUDirective2002/95/EC (at time of this printing). However, RF Micro Devices reserves the right to make changes to its products without notice. RF Micro Devices does not assume responsibility for the use of the described product(s).

Parameter	Specification			Unit	Condition
	Min.	Typ.	Max.		
Overall					Temp=25 °C, V _{CC} =3.6V, V _{APC1,2} =2.8V, V _{AT_EN} =0V, P _{IN} =+5.5dBm, Freq=1710MHz to 1910MHz, 37.5% Duty Cycle, pulse width=1731 μs See application schematic for tuning details. A different tuning is required.
Operating Frequency Range		1710 to 1785		MHz	
		1850 to 1910		MHz	
Usable Frequency Range		1700 to 2000		MHz	
Maximum Output Power	+32.3	+33		dBm	Temp=+25°C, V _{CC} =3.6V, V _{APC1,2} =2.8V
	+32	+32.8		dBm	Temp=+25°C, V _{CC} =3.3V, V _{APC1,2} =2.8V
	+30.4	+32.5		dBm	Temp=+60°C, V _{CC} =3.3V, V _{APC1,2} =2.8V
Total Efficiency	43	49		%	At P _{OUT,MAX} , V _{CC} =3.6V
		15		%	P _{OUT} =+20dBm
		10		%	P _{OUT} =+10dBm
Recommended Input Power Range	+5.5	+8.0	+10.0	dBm	
Output Noise Power			-79	dBm	RBW=100kHz, 1805MHz to 1880MHz and 1930MHz to 1990MHz, P _{OUT,MIN} <P _{OUT} <P _{OUT,MAX} , P _{IN,MIN} <P _{IN} <P _{IN,MAX} , V _{CC} =3.0V to 5.0V
Forward Isolation		-37	-25	dBm	V _{APC1,2} =0.3V, P _{IN} =+10dBm
Second Harmonic		-20	-7	dBm	P _{OUT} ≤+32.3dBm; P _{IN} =+10dBm
Third Harmonic		-20	-7	dBm	P _{IN} =+10dBm
All Other Non-Harmonic Spurious			-36	dBm	
Input Impedance		50		Ω	
Input VSWR			2.5:1		P _{OUT,MAX} -5dB<P _{OUT} <P _{OUT,MAX}
			3:1		P _{OUT} <P _{OUT,MAX} -5dB
Output Load VSWR					
Stability	8:1				Spurious<-36dBm, V _{APC1,2} =0.3V to 2.6V, RBW=100kHz
Ruggedness	10:1				No damage
Output Load Impedance		4.5-j3.9		Ω	Load Impedance presented at RF OUT pin

Parameter	Specification			Unit	Condition
	Min.	Typ.	Max.		
Power Control					
Power Control "ON"			3.0	V	Maximum P _{OUT} , Voltage supplied to the input
Power Control "OFF"	0.3	0.5		V	Minimum P _{OUT} , Voltage supplied to the input
Power Control Range	62	68		dB	V _{APC1,2} =0.3V to 2.8V, V _{AT_EN} =2.7V, P _{IN} =+8dBm
Gain Control Slope		100		dB/V	P _{OUT} =-10dBm to +33dBm
APC Input Capacitance			10	pF	DC to 2MHz
APC Input Current		4.5	5	mA	V _{APC1,2} =2.8V
Turn On/Off Time			10	μA	V _{APC1,2} =0V
			100	ns	
Power Supply					
Power Supply Voltage		3.5		V	Specifications
	2.7		4.8	V	Nominal operating limits, P _{OUT} <+33dBm
			5.5	V	With maximum output load VSWR 6:1, P _{OUT} <+33dBm
Power Supply Current		1.3		A	DC Current at P _{OUT,MAX}
	5		295	mA	Idle Current, P _{IN} <-30dBm, V _{APC} =2.6V
		1	10	μA	P _{IN} <-30dBm, V _{APC1,2} =0.2V
		1	10	μA	P _{IN} <-30dBm, V _{APC1,2} =0.2V, Temp=+85°C

RF5111

Pin	Function	Description	Interface Schematic
1	VAT EN	Control pin for the pin diode. The purpose of the pin diode is to attenuate RF drive level when V_{APC} is low. This serves to reduce RF leakage through the device caused by self-biasing under high RF drive levels. A good input match is maintained when the input stage bias is turned off by the same mechanism. When this pin is set high, pin diode attenuation control is turned on. (See Theory of Operation for details.)	
2	RF IN	RF Input. This is a 50Ω input, but the actual impedance depends on the interstage matching network connected to pin 5. An external DC blocking capacitor is required if this port is connected to a DC path to ground or a DC voltage.	
3	GND1	Ground connection for the preamplifier stage. For best performance, keep traces physically short and connect immediately to the ground plane. It is important for stability that this pin has its own vias to the groundplane, to minimize any common inductance.	See pin 2.
4	VCC1	Power supply for the preamplifier stage and interstage matching. This pin forms the shunt inductance needed for proper tuning of the interstage match. Refer to the application schematic for proper configuration, and note that position and value of the components are important.	See pin 2.
5	APC1	Power Control for the driver stage and preamplifier. When this pin is "low", all circuits are shut off. A "low" is typically 0.5V or less at room temperature. A shunt bypass capacitor is required. During normal operation this pin is the power control. Control range varies from approximately 1.0V for -10dBm to 2.6V for +33dBm RF output power. The maximum power achievable depends on the actual output matching; see the application information for more details. The maximum current into this pin is 5mA when $V_{APC1}=2.6V$, and 0mA when $V_{APC}=0V$.	
6	APC2	Power control for the output stage. See pin 6 for more details.	See pin 6.
7	VCC	Power supply for the bias circuits.	See pin 6.
8	NC	Not connected.	
9	NC	Not connected.	
10	RF OUT	RF output and power supply for the output stage. Bias voltage for the final stage is provided through this wide output pin. An external matching network is required to provide the optimum load impedance.	
11	RF OUT	Same as pin 10.	Same as pin 10.
12	RF OUT	Same as pin 10.	Same as pin 10.
13	2F0	Connection for the second harmonic trap. This pin is internally connected to the RF OUT pins. The bonding wire together with an external capacitor form a series resonator that should be tuned to the second harmonic frequency in order to increase efficiency and reduce spurious outputs.	Same as pin 10.

RF5111

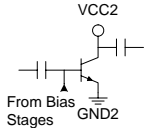
Pin	Function	Description	Interface Schematic
14	VCC2	Power supply for the driver stage. This pin forms the shunt inductance needed for proper tuning of the second interstage match.	 <p>The schematic shows a transistor with its base connected to a signal source labeled 'From Bias Stages'. The collector is connected to a series capacitor, which is then connected to the VCC2 pin. A shunt inductor is connected between the VCC2 pin and the emitter of the transistor. The emitter is connected to a ground point labeled GND2.</p>
15	VCC2	Same as pin 14.	Same as pin 14.
16	VCC2	Same as pin 14.	Same as pin 14.
Pkg Base	GND	Ground connection for the output stage. This pad should be connected to the groundplane by vias directly under the device. A short path is required to obtain optimum performance, as well as to provide a good thermal path to the PCB for maximum heat dissipation.	

Theory of Operation and Application Information

The RF5111 is a three-stage device with 28 dB gain at full power. Therefore, the drive required to fully saturate the output is +5dBm. Based upon HBT (Heterojunction Bipolar Transistor) technology, the part requires only a single positive 3V supply to operate to full specification. Power control is provided through a single pin interface, with a separate Power Down control pin. The final stage ground is achieved through the large pad in the middle of the backside of the package. First and second stage grounds are brought out through separate ground pins for isolation from the output. These grounds should be connected directly with vias to the PCB ground plane, and not connected with the output ground to form a so called “local ground plane” on the top layer of the PCB. The output is brought out through the wide output pad, and forms the RF output signal path.

The amplifier operates in near Class C bias mode. The final stage is “deep AB”, meaning the quiescent current is very low. As the RF drive is increased, the final stage self-biases, causing the bias point to shift up and, at full power, draws about 1500mA. The optimum load for the output stage is approximately 4.5Ω . This is the load at the output collector, and is created by the series inductance formed by the output bond wires, vias, and microstrip, and 2 shunt capacitors external to the part. The optimum load impedance at the RF Output pad is $4.5-j3.9\Omega$. With this match, a 50Ω terminal impedance is achieved. The input is internally matched to 50Ω with just a blocking capacitor needed. This data sheet defines the configuration for GSM operation.

The input is DC coupled; thus, a blocking cap must be inserted in series. Also, the first stage bias may be adjusted by a resistive divider with high value resistors on this pin to V_{PC} and ground. For nominal operation, however, no external adjustment is necessary as internal resistors set the bias point optimally.

When the device is driven at maximum input power self biasing would occur. This results in less isolation than one would expect, and the maximum output power would be about -15dBm. If the drive power to the PA is turned on before the GSM ramp-up, higher isolation is required. In order to meet the GSM system specs under those conditions, a PIN diode attenuator connected to the input can be turned on. The figure below shows how the attenuator and its controls are connected.

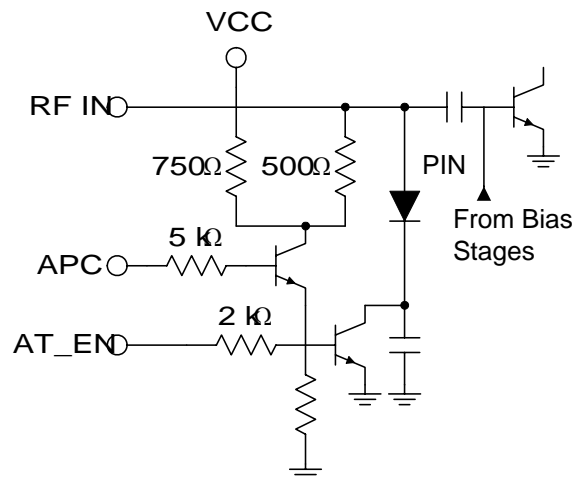

The current through the PIN diode is controlled by two signals: AT_EN and APC. The AT_EN signal allows current through the PIN diode and is an on/off function. The APC signal controls the amount of current through the PIN diode. Normally, the AT_EN signal will be derived from the VCO ENABLE signal available in most GSM handset designs. If maximum isolation is needed before the ramp-up, the AT_EN signal needs to be turned on before the RF power is applied to the device input. The current into this pin is not critical, and can be reduced to a few hundred micro amps with an external series resistor. Without the resistor, the pin will draw about 700μA.

Because of the inverting stage at the APC input, the current through the PIN diode is inverted from the APC voltage. Thus, when V_{APC} is high for maximum output power, the attenuator is turned off to obtain maximum drive level for the first RF stage. When V_{APC} is low for maximum isolation, the attenuator is be turned on to reduce the drive level and to avoid self-biasing.

The PIN diode is dimensioned such that a low V_{APC} the impedance of the diode is about 50 Ohm. Since the input impedance of the first RF stage become very high when the bias is turned off, this topology will maintain a good input impedance over the entire V_{APC} control range.

VCC1 and VCC2 provide supply voltage to the first and second stage, as well as provides some frequency selectivity to tune to the operating band. Essentially, the bias is fed to this pin through a short microstrip. A bypass capacitor sets the inductance seen by the part, so placement of the bypass cap can affect the frequency of the gain peak. This supply should be bypassed individually with 100pF capacitors before being combined with V_{CC} for the output stage to prevent feedback and oscillations.

The RF OUT pin provides the output power. Bias for the final stage is fed to this output line, and the feed must be capable of supporting the approximately 1.5A of current required. Care should be taken to keep the losses low in the bias feed and output components. A narrow microstrip line is recommended because DC losses in a bias choke will degrade efficiency and power.

While the part is safe under CW operation, maximum power and reliability will be achieved under pulsed conditions. The data shown in this data sheet is based on a 12.5% duty cycle and a 600 μ s pulse, unless specified otherwise.

The part will operate over a 3.0V to 5.0V range. Under nominal conditions, the power at 3.5V will be greater than +32dBm at +85°C. As the voltage is increased, however, the output power will increase. Thus, in a system design, the ALC (Automatic Level Control) Loop will back down the power to the desired level. This must occur during operation, or the device may be damaged from too much power dissipation. At 5.0V, over +36dBm may be produced; however, this level of power is not recommended, and can cause damage to the device.

The HBT breakdown voltage is >20V, so there is no issue with overvoltage. However, under worst-case conditions, with the RF drive at full power during transmit, and the output VSWR extremely high, a low load impedance at the collector of the output transistors can cause currents much higher than normal. Due to the bipolar nature of the devices, there is no limitation on the amount of current the device will sink, and the safe current densities could be exceeded.

High current conditions are potentially dangerous to any RF device. High currents lead to high channel temperatures and may force early failures. The RF5111 includes temperature compensation circuits in the bias network to stabilize the RF transistors, thus limiting the current through the amplifier and protecting the devices from damage. The same mechanism works to compensate the currents due to ambient temperature variations.

To avoid excessively high currents it is important to control the V_{APC} when operating at supply voltages higher than 4.0V, such that the maximum output power is not exceeded.

RF5111

Application Schematic

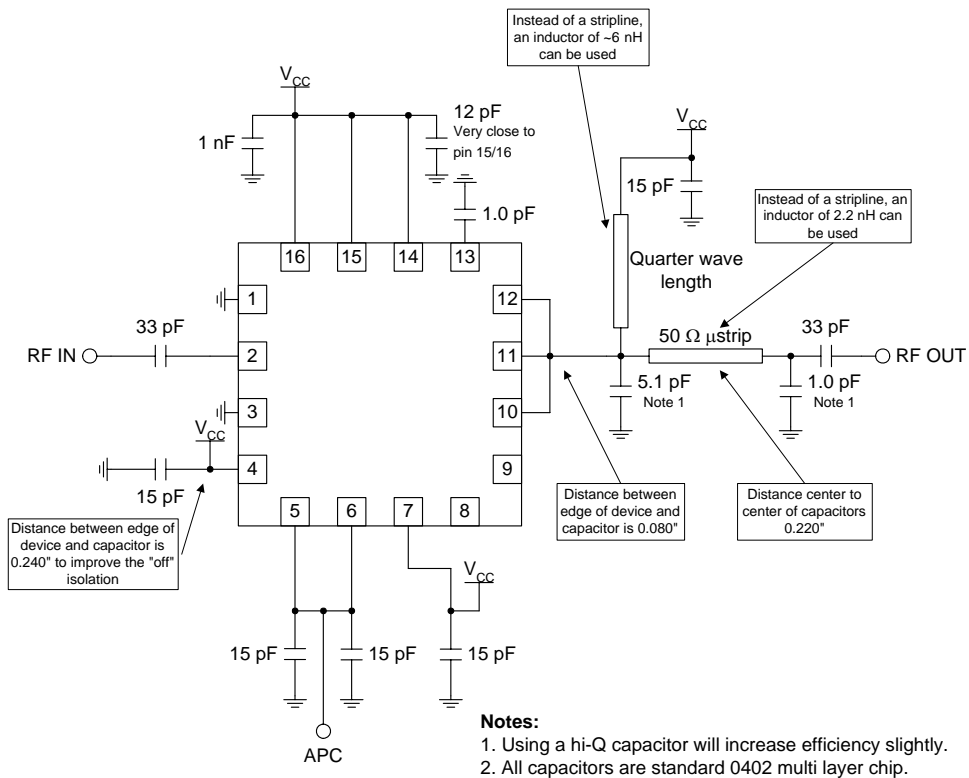

Internal Schematic

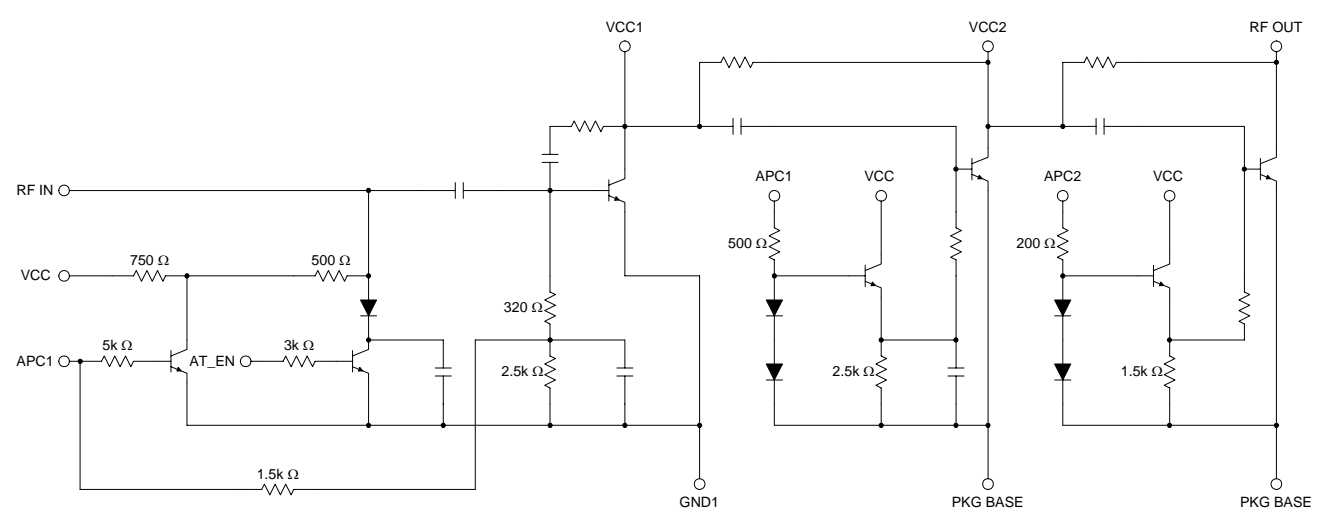

RF5111

Evaluation Board Schematic Dual-Band DCS/PCS Lumped Element

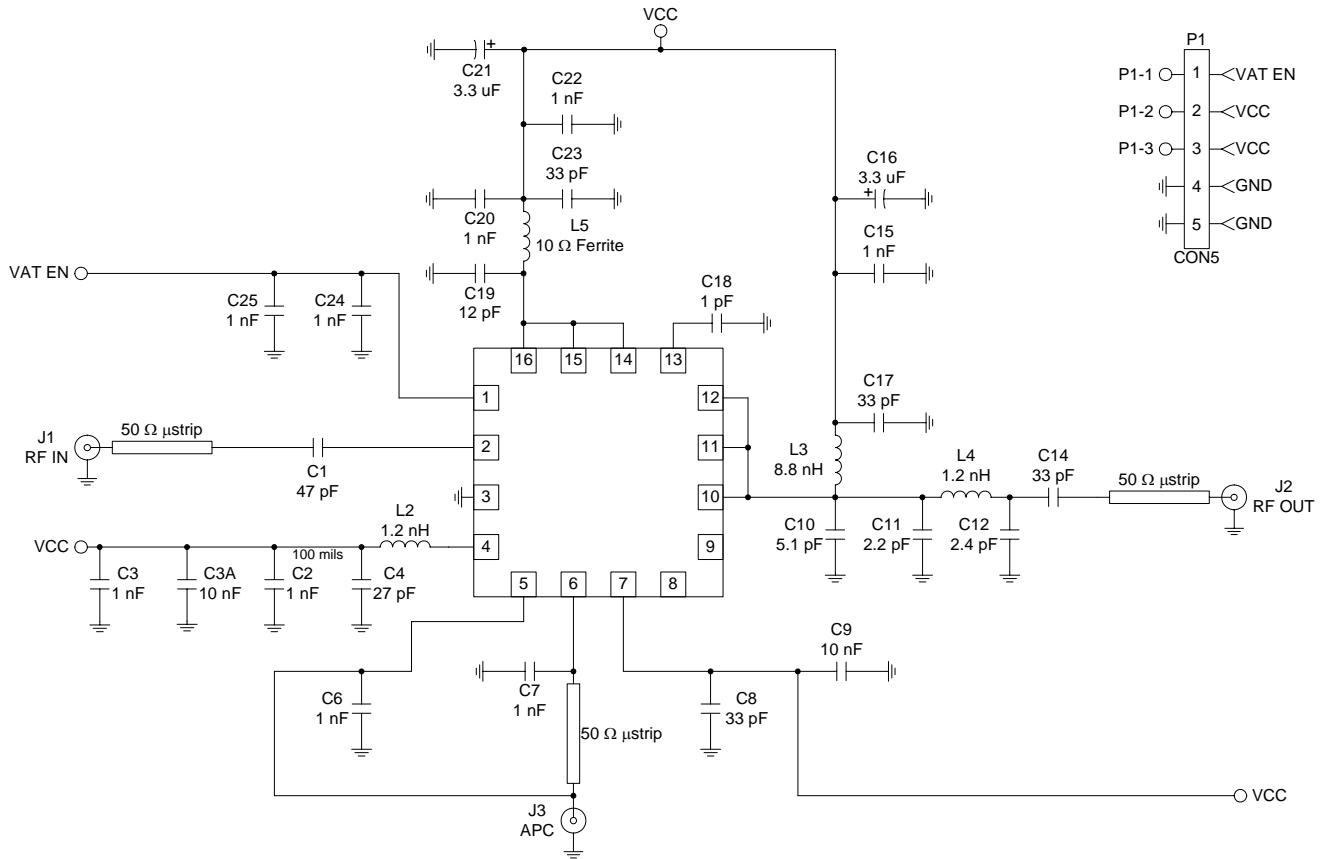

Evaluation Board Layout

Board Size 2.0" x 2.0"
Board Thickness 0.032", Board Material FR-4, Multi-Layer

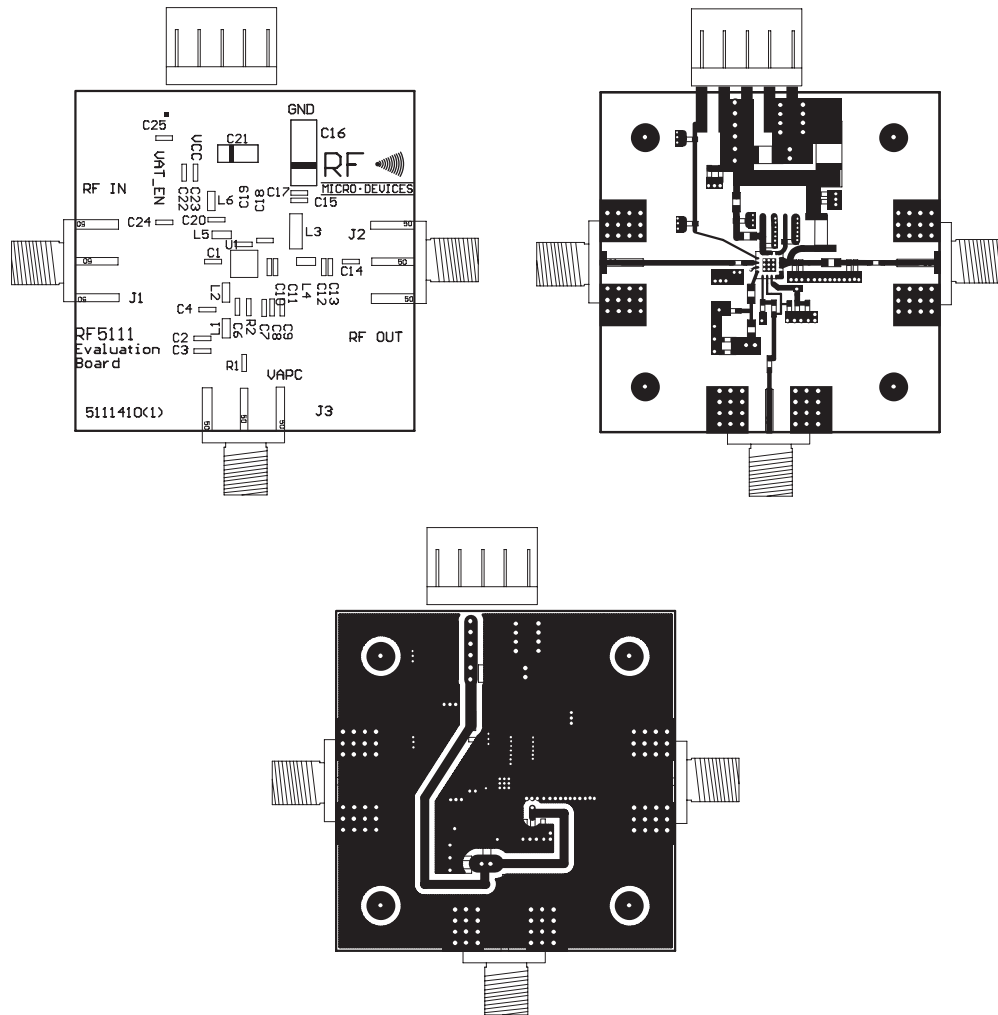

Typical Test Setup

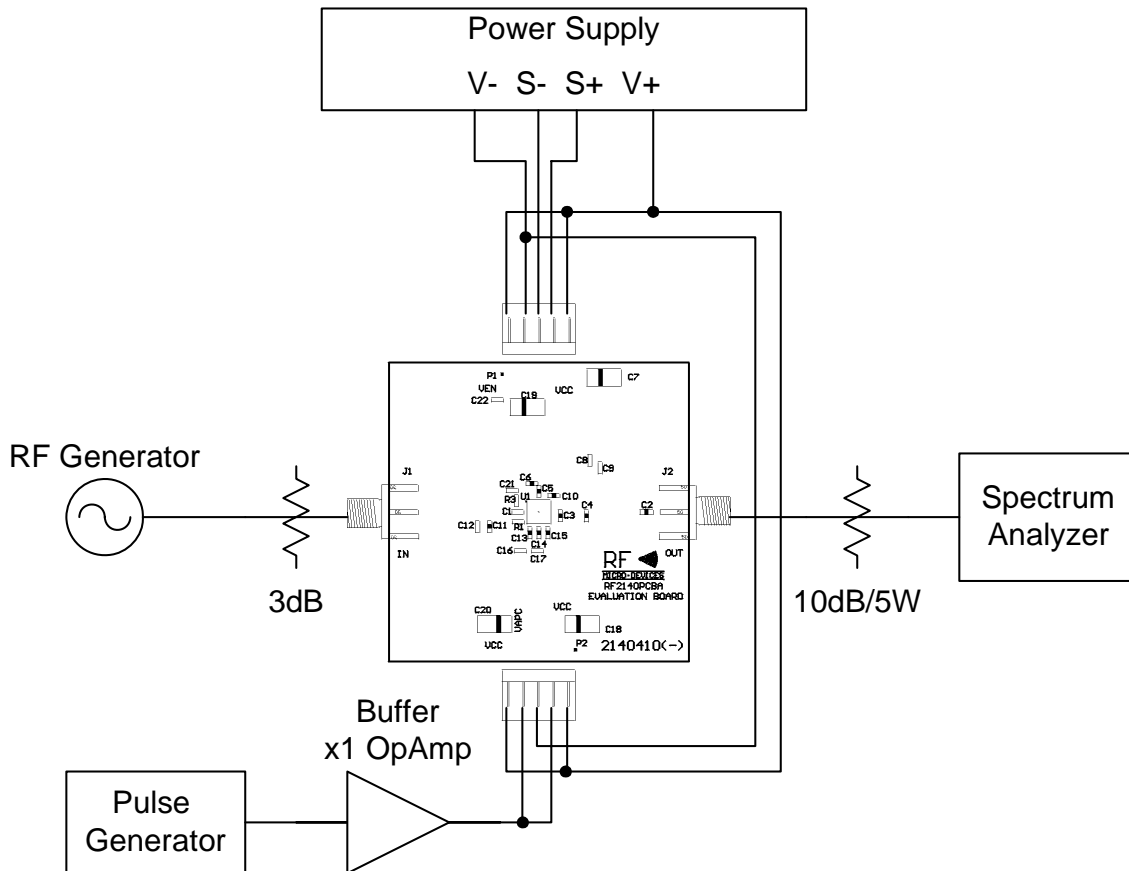

A buffer amplifier is recommended because the current into the V_{APC} changes with voltage. As an alternative, the voltage may be monitored with an oscilloscope.

Notes about testing the RF5111

The test setup shown above includes two attenuators. The 3dB pad at the input is to minimize the effects that the switching of the input impedance of the PA has on the signal generator. When V_{APC} is switched quickly, the resulting input impedance change can cause the signal generator to vary its output signal, either in output level or in frequency. Instead of an attenuator an isolator may also be used. The attenuator at the output is to prevent damage to the spectrum analyzer, and should be able to handle the power.

It is important not to exceed the rated supply current and output power. When testing the device at higher than nominal supply voltage, the V_{APC} should be adjusted to avoid the output power exceeding +36dBm. During load-pull testing at the output it is important to monitor the forward power through a directional coupler. The forward power should not exceed +36dBm, and V_{APC} needs to be adjusted accordingly. This simulates the behavior for the power control loop in this respect. To avoid damage, it is recommended to set the power supply to limiting the current during the burst, not to exceed the maximum current rating.

PCB Design Requirements

PCB Surface Finish

The PCB surface finish used for RFMD's qualification process is electroless nickel, immersion gold. Typical thickness is 3μinch to 8μinch gold over 180μinch nickel.

PCB Land Pattern Recommendation

PCB land patterns are based on IPC-SM-782 standards when possible. The pad pattern shown has been developed and tested for optimized assembly at RFMD; however, it may require some modifications to address company specific assembly processes. The PCB land pattern has been developed to accommodate lead and package tolerances.

PCB Metal Land Pattern

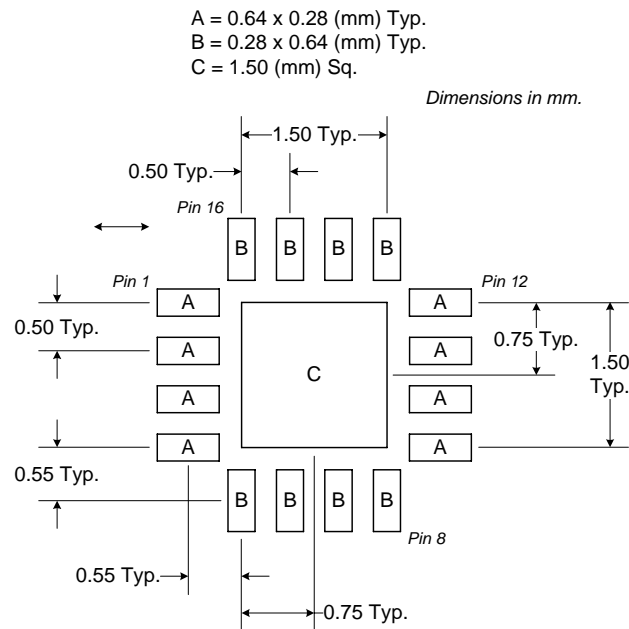

Figure 1. PCB Metal Land Pattern (Top View)

RF5111

PCB Solder Mask Pattern

Liquid Photo-Imageable (LPI) solder mask is recommended. The solder mask footprint will match what is shown for the PCB metal land pattern with a 2mil to 3mil expansion to accommodate solder mask registration clearance around all pads. The center-grounding pad shall also have a solder mask clearance. Expansion of the pads to create solder mask clearance can be provided in the master data or requested from the PCB fabrication supplier.

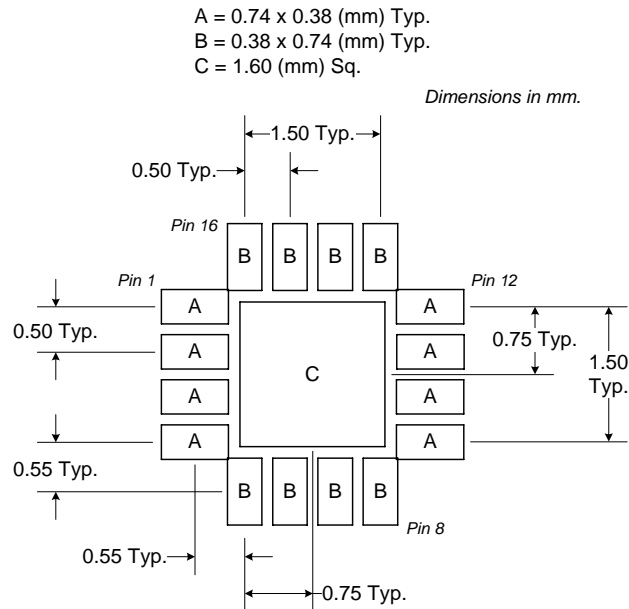

Figure 2. PCB Solder Mask Pattern (Top View)

Thermal Pad and Via Design

The PCB land pattern has been designed with a thermal pad that matches the die paddle size on the bottom of the device.

Thermal vias are required in the PCB layout to effectively conduct heat away from the package. The via pattern has been designed to address thermal, power dissipation and electrical requirements of the device as well as accommodating routing strategies.

The via pattern used for the RFMD qualification is based on thru-hole vias with 0.203mm to 0.330mm finished hole size on a 0.5mm to 1.2mm grid pattern with 0.025mm plating on via walls. If micro vias are used in a design, it is suggested that the quantity of vias be increased by a 4:1 ratio to achieve similar results.