



# RF5924

## 3.7V, SINGLE-BAND FRONT-END MODULE

### RoHS Compliant & Pb-Free Product

#### Typical Applications

- IEEE802.11b/g WLAN Applications
- Single-Chip RF Front-End Module
- 2.5GHz ISM Bands Applications
- Wireless LAN Systems
- Portable Battery-Powered Equipment
- Opt. Bluetooth Sharing of Single Antenna Port

#### Product Description

The RF5924 FEM is a single integrated module for high-performance WLAN applications in the 2.4GHz to 2.5GHz ISM band. The FEM has integrated b/g power amplifier, power detector, RX balun, and TX filtering. Also, it is capable of switching between WLAN RX, WLAN TX and BTH RX/TX operations. It has low insertion loss at the 2.4GHz to 2.5GHz WLAN and BTH paths. The device is provided in a 3.5mmx3.5mm, 16-pin package. This module meets or exceeds the RF front-end needs of 802.11b/g WLAN RF systems.

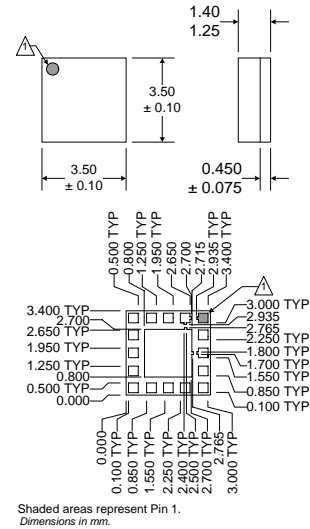

Package Style: 3.5mm x 3.5mm

#### Optimum Technology Matching® Applied

- |   |                                   |                                       |
|---|-----------------------------------|---------------------------------------|
| <input type="checkbox"/> Si BJT               | <input type="checkbox"/> GaAs HBT | <input type="checkbox"/> GaAs MESFET  |
| <input type="checkbox"/> Si Bi-CMOS           | <input type="checkbox"/> SiGe HBT | <input type="checkbox"/> Si CMOS      |
| <input checked="" type="checkbox"/> InGaP/HBT | <input type="checkbox"/> GaN HEMT | <input type="checkbox"/> SiGe Bi-CMOS |
| <input checked="" type="checkbox"/> pHEMT     |                                   |                                       |

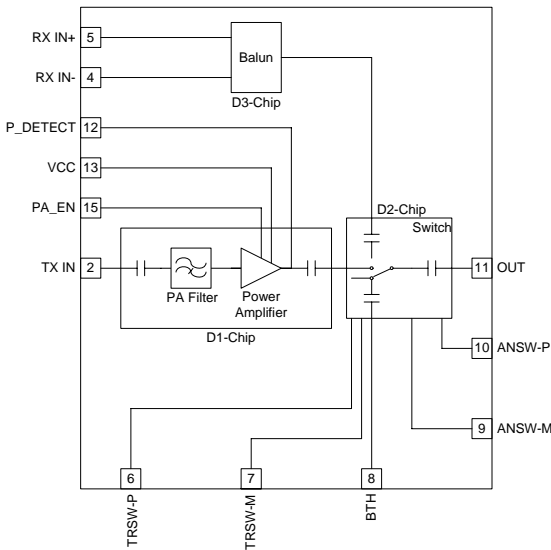

Functional Block Diagram

#### Features

- Single-Module Radio Front-End
- Single Supply Voltage 3.1V to 4.5V
- Integrated 2.5GHz b/g Amplifier, RX Balun and Switch
- P<sub>OUT</sub>= 16dBm, 11g, OFDM<3.3% EVM

#### Ordering Information

RF5924 3.7V, Single-Band Front-End Module  
 RF5924PCBA-41X Fully Assembled Evaluation Board

RF Micro Devices, Inc.  
 7628 Thorndike Road  
 Greensboro, NC 27409, USA

Tel (336) 664 1233  
 Fax (336) 664 0454  
<http://www.rfmd.com>

**RF5924**

*Please contact  
RF Micro Devices  
Applications Engineering  
at (336) 678-5570  
for more information.*