

1000 W, 50 V, HF to 500 MHz RF power LDMOS transistor

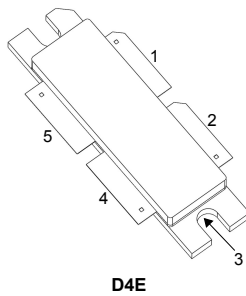

D4E

Pin connection	
Pin	Connection
1	Drain A
2	Drain B
3	Source (bottom side)
4	Gate B
5	Gate A



Product status link
RF5L051K0CB4

Product summary	
Order code	RF5L051K0CB4
Marking	5L051K0
Package	D4E
Packing	Tray
Base/bulk quantity	20/100

Features

Order code	Frequency	V _{DD}	P _{OUT}	Gain	Efficiency
RF5L051K0CB4	108 MHz	50 V	1000 W	21 dB	77%

- High efficiency and linear gain operations
- Integrated ESD protection
- Large positive and negative gate-source voltage range for improved class C operation
- On chip RC network enable high stability and ruggedness
- Excellent thermal stability, low HCI drift
- In compliance with the european directive 2002/95/EC

Applications

- 30-88 MHz/136-174 MHz ground communication
- 1.6-30 MHz HF transceiver
- Plasma generator
- Particle accelerator
- FM and VHF TV broadcast

Description

The **RF5L051K0CB4** is a 1000 W, 50 V, high performance, unmatched LDMOS FET, designed for wideband commercial and industrial applications in the frequency range from HF to 500 MHz. It can be used for both CW and pulse application. It is featured for high power and high ruggedness, suitable for industrial, scientific and medical application, as well as FM radio, VHF TV and aerospace applications.

1 Electrical ratings

Table 1. Absolute maximum ratings ($T_C = 25\text{ °C}$)

Symbol	Parameter	Value	Unit
V_{DS}	Drain-source voltage	110	V
V_{GS}	Gate-source voltage	-8 to 10	V
V_{DD}	Maximum operating voltage	55	V
T_{STG}	Storage temperature range	-65 to 150	°C
T_J	Maximum junction temperature	200	°C

Table 2. Thermal data

Symbol	Parameter	Value	Unit
$R_{thJC}^{(1)}$	Thermal resistance, junction-to-case	0.15	°C/W

1. $T_C = 80\text{ °C}$, $P_{OUT} = 1000\text{ W}$, CW, DC test.

Table 3. ESD protection

Symbol	Test methodology	Class
HBM	Human body model (according to ANSI/ESDA/JEDEC JS001-2017)	2
CDM	Charge device model (according to ANSI/ESDA/JEDEC JS002-2014)	C3

2 Electrical characteristics

$T_C = 25\text{ }^\circ\text{C}$ unless otherwise specified.

Table 4. Static (per side)

Symbol	Parameter	Test conditions	Min.	Typ.	Max.	Unit
$V_{(BR)DSS}$	Drain-source breakdown voltage	$V_{GS} = 0\text{ V}, I_D = 100\text{ }\mu\text{A}$	110			V
I_{DSS}	Zero gate voltage drain leakage current	$V_{GS} = 0\text{ V}, V_{DS} = 50\text{ V}$			1	μA
		$V_{GS} = 0\text{ V}, V_{DS} = 90\text{ V}$				
I_{GSS}	Gate-source leakage current	$V_{GS} = -8/10\text{ V}, V_{DS} = 0\text{ V}$			± 100	nA
$V_{GS(th)}$	Gate threshold voltage	$V_{DS} = 50\text{ V}, I_D = 600\text{ }\mu\text{A}$	2.0		2.8	V
$V_{GS(Q)}$	Gate quiescent voltage	$V_{DS} = 1\text{ V}, I_D = 400\text{ mA}$	2		5	V
$V_{DS(on)}$	Static drain-source on-voltage	$V_{GS} = 10\text{ V}, I_D = 5\text{ A}$			600	mV
$I_{DS(on)}$	Static drain-source on-current	$V_{GS} = 10\text{ V}, V_{DS} = 100\text{ mV}$			2.5	A
$R_{DS(on)}$	Drain-source on-state resistance	$V_{GS} = 10\text{ V}, V_{DS} = 100\text{ mV}$			1	Ω
C_{iss}	Common source input capacitance	$V_{GS} = 0\text{ V}, V_{DD} = 50\text{ V}, f = 1\text{ MHz}$		430		pF
C_{rss}	Common source feedback capacitance			1.6		pF
C_{oss}	Common source output capacitance			100		pF

Table 5. Dynamic

Symbol	Parameter	Test conditions	Min.	Typ.	Max.	Unit
f	Frequency				500	MHz
P_{OUT}	Output power	f = 108 MHz, 2.5 dB compression	-	1000		W
G_{PS}	Power gain		-	21		dB
η_D	Drain efficiency		-	77		%
VSWR	Load mismatch	$P_{OUT} = 1000\text{ W}$, all phases	-		10:1	

Note: $V_{DD} = 50\text{ V}, I_{DQ} = 200\text{ mA}$, pulsed CW, pulse width = 100 μs , duty cycle = 10%

3 Typical performances

Figure 1. Power gain and drain efficiency vs output power (f = 108 MHz)

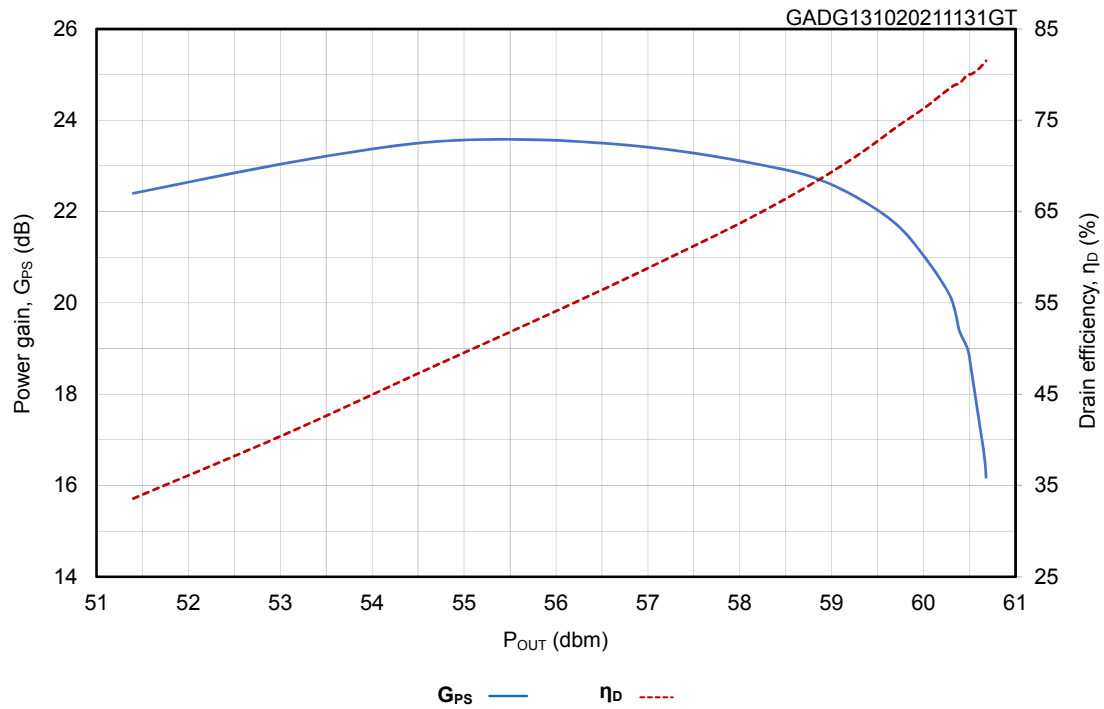

Note: $V_{DD} = 50\text{ V}$, $I_{DQ} = 200\text{ mA}$, pulsed CW, pulse width = 100 μs , duty cycle = 10%

4 Test circuits

Figure 2. Test circuit layout (f = 108 MHz)

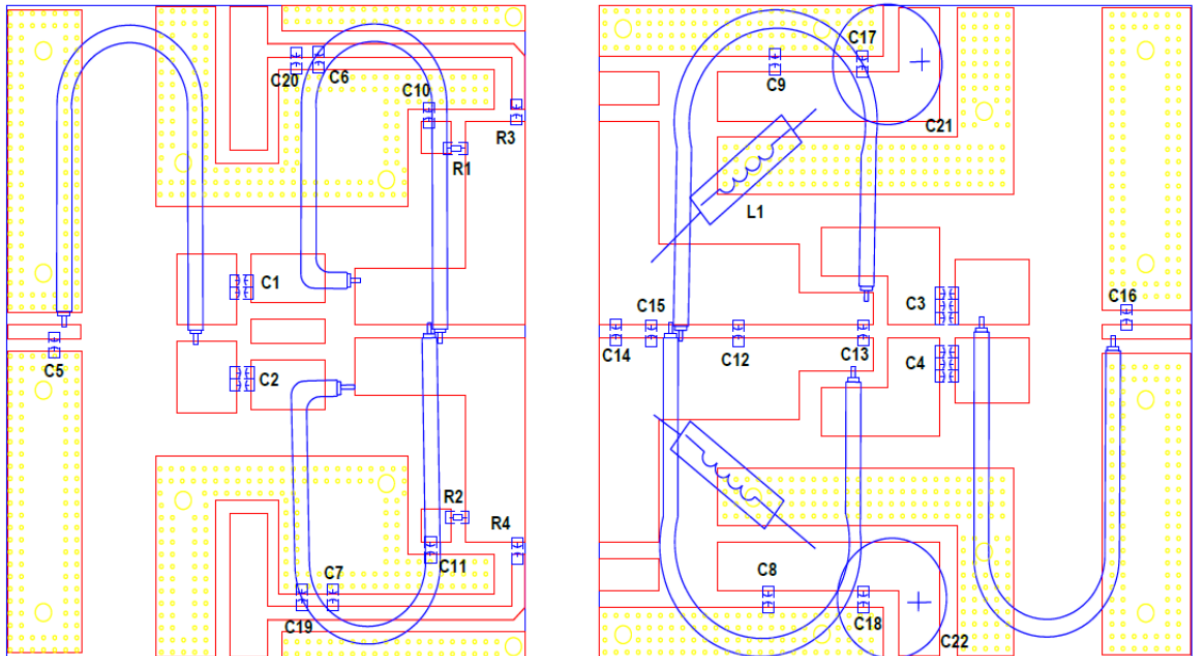

GADG210520211203GT

Figure 3. Test circuit photo

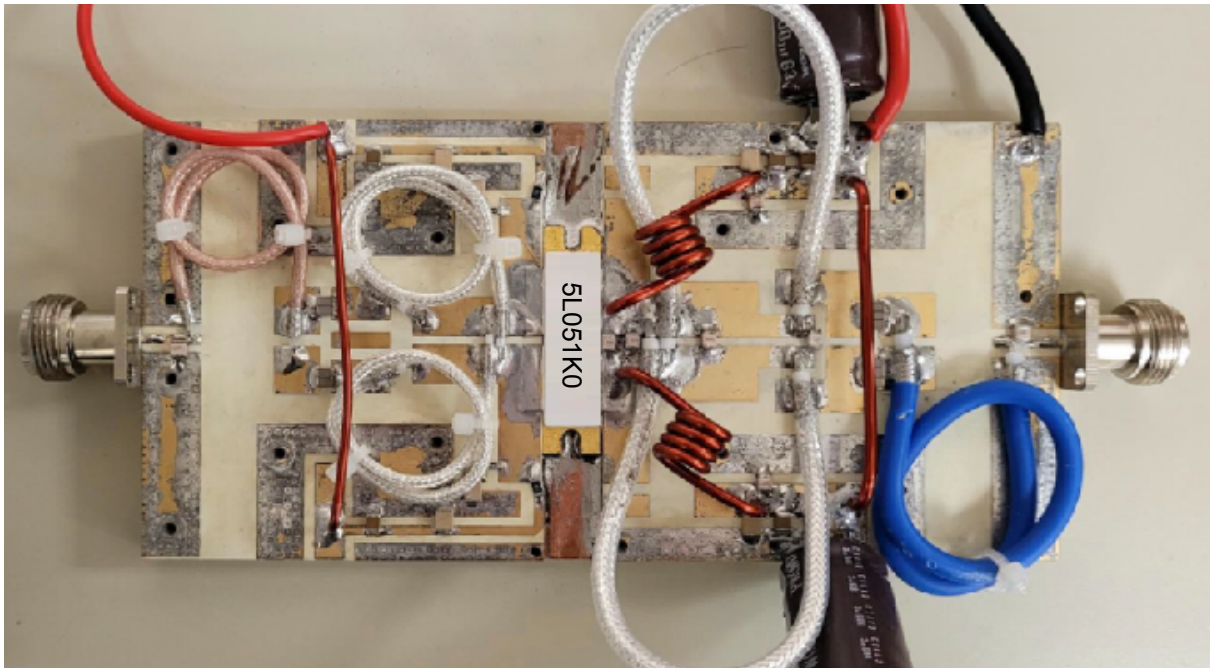

GADG131020211147GT

Table 6. Components list

Component	Value	Reference
C1, C2	470 pF (2x)	ATC800B
C3, C4	470 pF (3x)	ATC800B
C5	33 pF	DLC70B
C6, C7, C8, C9, C10, C11	100 nF	C4532X7R3D103KT000N
C12, C13, C14, C15	20 pF	DLC70B
C16	3.9 pF	DLC70B
C17, C18, C19, C20	10 μ F	100 V ceramic capacitor
C21, C22	2200 μ F	63 V electrolytic capacitor
R1, R2	16 Ω	0805 chip resistor
R3, R4	470 Ω	0805 chip resistor
T1	50 Ω , 150 mm	SFF-50-1.5
T2, T3	25 Ω , line length = 150 mm, 9:1	SFF-25-1.5
T4, T5	12.5 Ω , line length = 150 mm, 9:1	SFF-12.5-1.5
T6	50 Ω , 150 mm	RG402-3
L1, L2	4 turns, Φ 1 mm	
PCB	0.762 mm (0.030") thick, $\epsilon_r = 3.48$, Rogers RO4350B, 1 oz. copper	

5 Package information

In order to meet environmental requirements, ST offers these devices in different grades of **ECOPACK** packages, depending on their level of environmental compliance. ECOPACK specifications, grade definitions and product status are available at: www.st.com. ECOPACK is an ST trademark.

5.1 D4E package information

Figure 4. D4E package outline

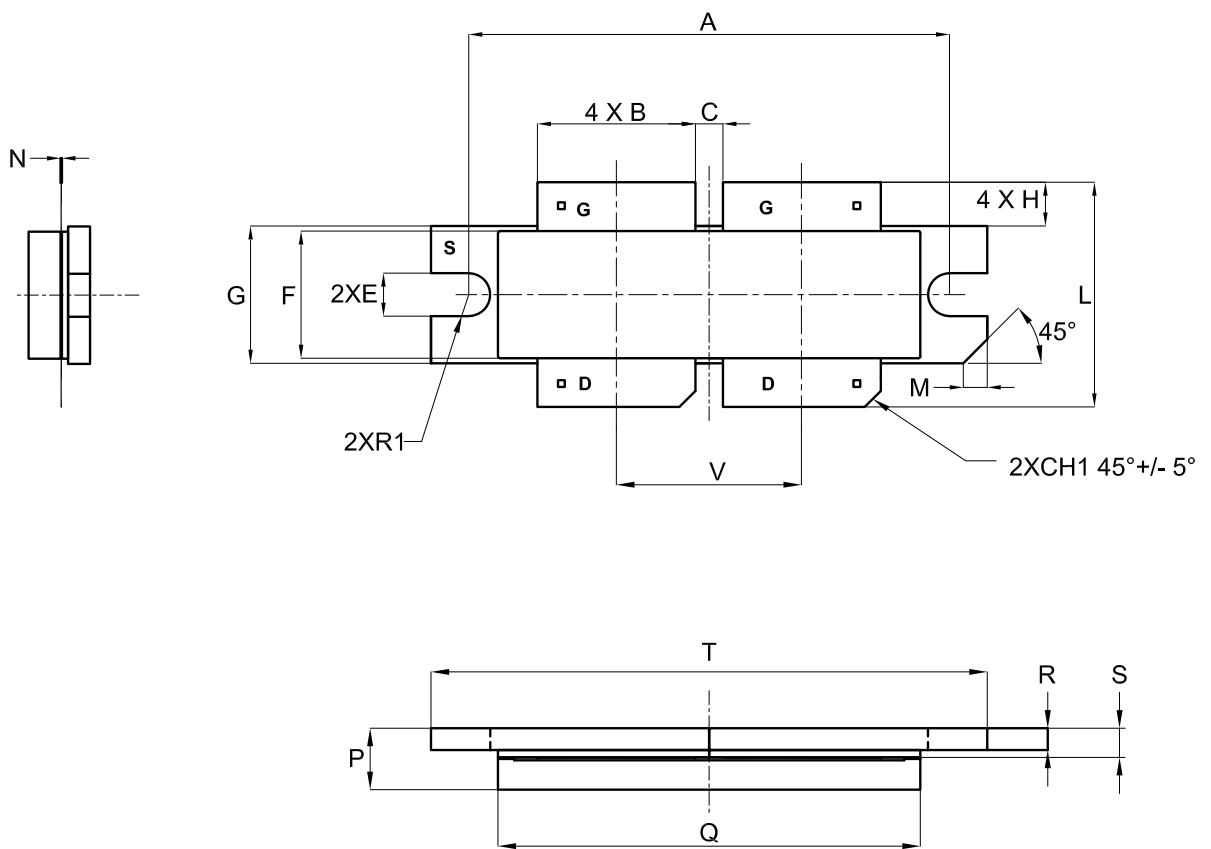

DM0066713_2

Table 7. D4E package mechanical data

Symbol	Millimeters		
	Min.	Typ.	Max.
A	35.44	35.56	35.68
B	11.56	11.68	11.80
C	1.92	2.04	2.16
E	3.06	3.18	3.30
F	9.25	9.40	9.50
G	10.04	10.16	10.28
H	5.72	5.85	3.48
L	16.11	16.62	17.13
M	1.51	1.78	2.05
N	0.10	0.13	0.16
P	4.17	4.55	4.93
Q	30.96	31.24	31.52
R	1.55	1.62	1.69
S	2.09	2.16	2.23
T	41.08	41.22	
V	13.60	13.72	13.84
R1		1.59	
CH1		1.19	

5.2 Marking information

Figure 5. Marking composition

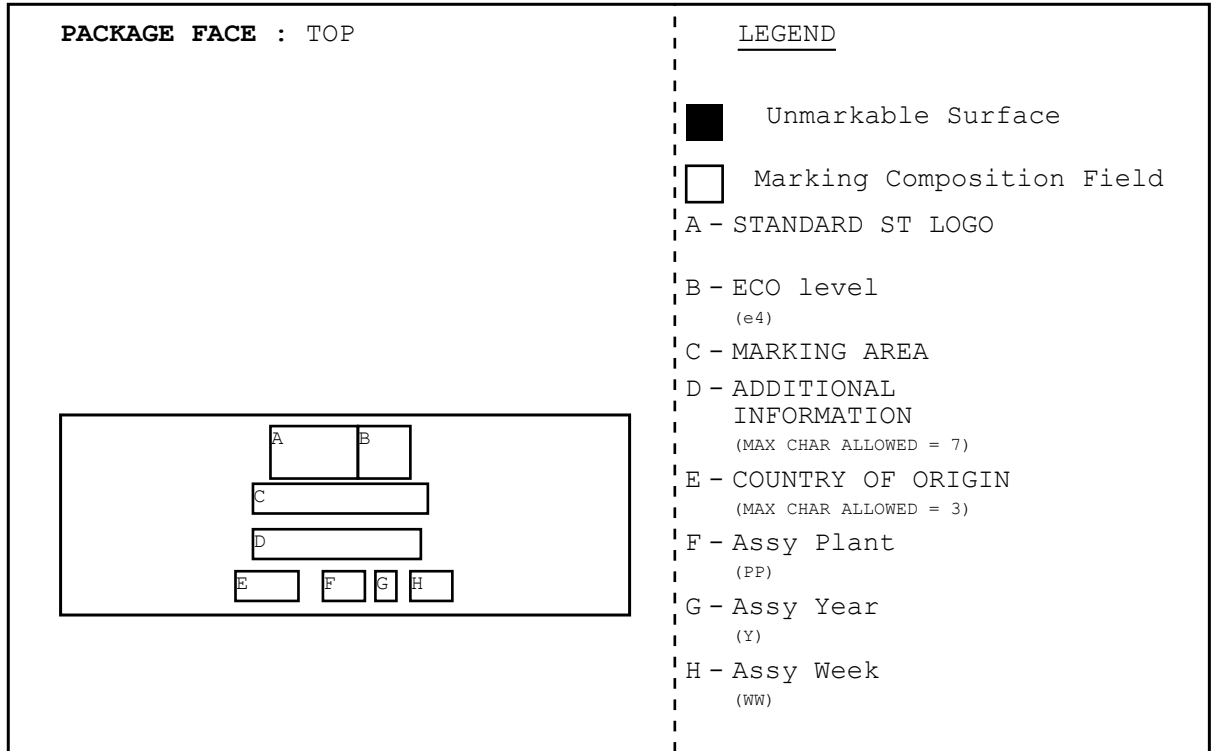

GADG040220211644GT

Revision history

Table 8. Document revision history

Date	Version	Changes
24-May-2021	1	First release.
14-Oct-2021	2	Updated Features and Description on cover page. Updated Table 1. Absolute maximum ratings ($T_C = 25\text{ °C}$). Updated Section 2 Electrical characteristics . Added Section 3 Typical performances . Updated Figure 3. Test circuit photo and Table 6. Components list .

Contents

1	Electrical data	2
2	Electrical characteristics	3
3	Typical performances	4
4	Test circuits	5
5	Package information	7
5.1	D4E package information	7
5.2	Marking information	9
	Revision history	10

IMPORTANT NOTICE – PLEASE READ CAREFULLY

STMicroelectronics NV and its subsidiaries (“ST”) reserve the right to make changes, corrections, enhancements, modifications, and improvements to ST products and/or to this document at any time without notice. Purchasers should obtain the latest relevant information on ST products before placing orders. ST products are sold pursuant to ST’s terms and conditions of sale in place at the time of order acknowledgement.

Purchasers are solely responsible for the choice, selection, and use of ST products and ST assumes no liability for application assistance or the design of Purchasers’ products.

No license, express or implied, to any intellectual property right is granted by ST herein.

Resale of ST products with provisions different from the information set forth herein shall void any warranty granted by ST for such product.

ST and the ST logo are trademarks of ST. For additional information about ST trademarks, please refer to www.st.com/trademarks. All other product or service names are the property of their respective owners.

Information in this document supersedes and replaces information previously supplied in any prior versions of this document.

© 2021 STMicroelectronics – All rights reserved