



SPECIFICATIONS

Model Number	RF62	RF65	RF63
Test Voltage (kV Peak) 60 Hz	9	9	9
Rated Operating Voltage (kV Peak) DC or 60 Hz	7	7	7
2.5 MHz	7	7	7
16 MHz	6	6	6
32 MHz	4	4	4
Continuous Current, Carry (Amps, RMS) DC or 60 Hz	10	10	10
2.5 MHz	10	10	10
16 MHz	6	6	6
32 MHz	5	5	5
Contact Capacitance (pF) Between Open Contacts	1.6	1.6	1.6
Open Contacts to Ground	1.1	1.1	1.1
Contact Resistance (mΩ)	20	20	20
Operate Time (ms. Max.)	10	10	10
Release Time (ms. Max.)	10	10	10
Pull-in Voltage @ 25° C			
26.5 VDC Coil	16	16	16
12 VDC Coil	8	N/A	N/A
Dropout Voltage @ -55 to +125° C			
26.5 VDC Coil	1-10	1-10	1-10
12 VDC Coil	1-5	N/A	N/A
Coil Resistance (Ohms ± 10%)			
26.5 VDC Coil	290	47	47
12 VDC Coil	48	N/A	N/A
Shock, 1/2 Sine 11 ms. (Peak g's)	50	50	50
Vibration, Peak g's 55-2000 Hz	10	10	10
Expected Mechanical Life Cycles (X10 ⁶)			
Weight, Ounces (Grams) Max.	1 (28)	1 (28)	1 (28)

MILITARY CROSS REFERENCE

Model Number	Military Specification	Military Drawing
RF62-26S	MIL-R-83725	M83725/16-002
RF62D-26S	MIL-R-83725	M83725/16-004
RF65-12S	MIL-R-83725	M83725/16-001
RF65D-12S	MIL-R-83725	M83725/16-003
RF63-26S	MIL-R-83725	M83725/13-001
RF63D-26S	MIL-R-83725	M83725/13-002

FLANGE CROSS REFERENCE

Model Number	Flange Version
RF62-26S	RF62D-26S
RF65-12S	RF65D-12S
RF63-26S	RF63D-26S0

FLANGE OUTLINE

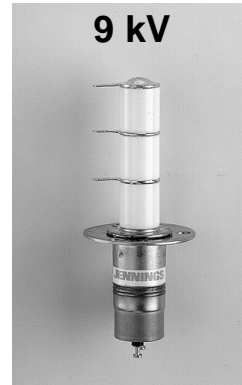
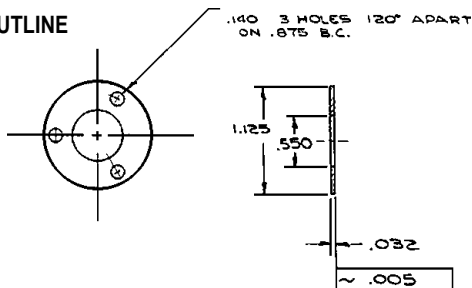

9 kV

- RF62-26S**
 High voltage relay for RF circuits to 76 MHz. (Photo shows flange version).
- RF65-12S**
 12 VDC version of RF62.

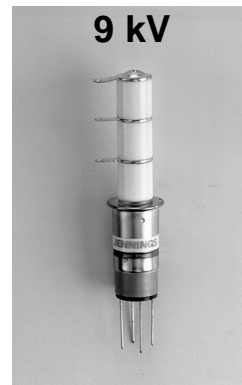
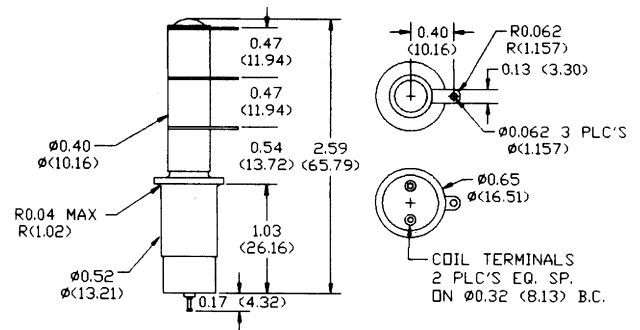

9 kV

- RF63-26S**
 Latching version of RF62. Ideal for switching digitally tuned transceivers & antenna couplers.

