

# RFFM8500Q

4.9GHz to 5.85GHz 802.11a/n  
Front End Module

The RFFM8500Q provides a complete integrated solution in a single Front End Module (FEM) for WiFi 802.11a/n systems. The ultra small form factor and integrated matching minimizes the layout area in the customer's application and greatly reduces the number of external components. This simplifies the total front end solution by reducing the bill of materials, system footprint, and manufacturability cost. The RFFM8500Q integrates a Power Amplifier (PA), Single Pole Double Throw switch (SPDT), LNA and a power detector coupler for improved accuracy. The device is provided in a 3mm x 3mm x 1.0mm, 16-pin laminate package. This module meets or exceeds the RF Front End needs of IEEE 802.11a/n WiFi RF systems. The RFFM8500Q is tested in accordance with the AEC-Q100 Standard.



Package: Laminate, 16-pin,  
3.0mm x 3.0mm x 1.05mm

## Features

- Tested in Accordance with AEC-Q100 Standard
- Single Supply Voltage 3.0V to 4.8V
- Integrated 5GHz Amplifier, SPT2T TX/RX Switch, LNA, and Power Detector Coupler
- $P_{OUT} = 16\text{dBm}$ , 11n, 2% Dynamic EVM; 3.3V

## Applications

- Automotive WiFi
- WiFi Direct
- Automotive Diagnostics
- WiFi Infotainment

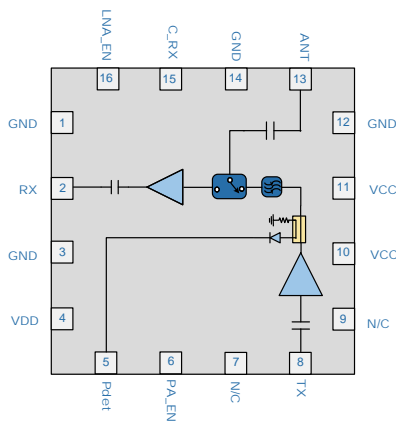

Functional Block Diagram

## Ordering Information

RFFM8500Q	Standard 5-piece sample bag
RFFM8500QSQ	Standard 25-piece sample bag
RFFM8500QSR	Standard 100-piece reel
RFFM8500QTR7	Standard 2500-piece reel
RFFM8500QPCBA-410	Fully assembled evaluation board

## Absolute Maximum Ratings

Parameter	Rating	Unit
DC Supply Voltage	5.5	V <sub>DC</sub>
Maximum TX and RX Input Power (No Damage)	5	dBm
Operating Ambient Temperature	-40 to +85	°C
Storage Temperature	-40 to +150	°C
Moisture Sensitivity	MSL3	



**Caution!** ESD sensitive device.



RFMD Green: RoHS status based on EU Directive 2011/65/EU (at time of this document revision), halogen free per IEC 61249-2-21, < 1000ppm each of antimony trioxide in polymeric materials and red phosphorus as a flame retardant, and <2% antimony in solder.

Exceeding any one or a combination of the Absolute Maximum Rating conditions may cause permanent damage to the device. Extended application of Absolute Maximum Rating conditions to the device may reduce device reliability. Specified typical performance or functional operation of the device under Absolute Maximum Rating conditions is not implied.

## Nominal Operating Parameters

Parameter	Specification			Unit	Condition	
	Min	Typ	Max			
<b>Transmit Parameters</b>					<b>Nominal Operating Conditions: P<sub>OUT</sub> = 16dBm; V<sub>CC</sub> = 3.3V; SW Control High: 3.1V; PA_EN = 3.1V; Freq = 5.18GHz to 5.825GHz; Modulation MCS7 20MHz; Duty Cycle = 50%; Temp = -40°C to +85°C; Unless Otherwise Noted</b>	
Frequency	5.15		5.825	GHz		
Power Supply VCC	3	3.3	3.6	V		
Switch Control Voltage-high	2.8	3.1	3.3	V	Control voltage tracks with V <sub>CC</sub>	
Switch Control Voltage-Low		0	0.2	V		
PA_EN						
	ON	2.8	3.1	3.6	V	PA_EN tracks with V <sub>CC</sub> . Do not use PA_EN higher than V <sub>CC</sub> .
	OFF		0	0.2	V	
Gain	23	30		dB	Temp = 25°C	
	22	29		dB	All conditions	
Dynamic EVM		2	2.5	%	P <sub>OUT</sub> = 16dBm; Temp = 25°C	
		2	2.5	%	P <sub>OUT</sub> = 13.5dBm; Temp = +85°C	
Quiescent Current		180	220	mA	RF off; Temp = 25°C	
		180	240	mA	RF off; All conditions	
Operating Current		230	260	mA	Temp = 25°C	
		235	285	mA	All conditions	
PA_EN Current		30	100	µA		
FEM Leakage Current		10	15	µA	RF off; PA_EN = OFF ; V <sub>CC</sub> = "ON"	
Second Harmonic		-45	-38	dBm	F <sub>0</sub> = 4.9GHz to 5.3GHz: P <sub>OUT</sub> = 18dBm; RBW = 1MHz	
		-46	-43	dBm	F <sub>0</sub> = 5.3GHz and 5.85GHz: P <sub>OUT</sub> = 18dBm; RBW = 1MHz	
Third Harmonic		-50	-43	dBm	F <sub>0</sub> = 5.15GHz to 5.85GHz: P <sub>OUT</sub> = 18dBm; RBW = 1MHz	
Power Detector	350	375	400	mV	P <sub>OUT</sub> = 0dBm	
	500	600	700	mV	P <sub>OUT</sub> = 16dBm	
TX Port Return Loss	8	15		dB	at TX input	
ANT Port Return Loss	10	15		dB	in TX mode	
PA Switching Time- V <sub>REF</sub> (on<->off)		200	600	nS		
PA Stability					Unconditional into 4:1 VSWR, No spurious above -41.25dBm/MHz	

Parameter	Specification			Unit	Condition
	Min	Typ	Max		
<b>Receive Parameters</b>					<b>Nominal Operating Conditions: <math>V_{DD} = 3.3V</math>; SW Control High: 3.1V; LNA_EN = 3.1V; Freq = 5.18GHz to 5.825GHz; Temp = -40°C to +85°C; Unless Otherwise Noted</b>
Frequency	5.15		5.825	GHz	
LNA Voltage Supply ( $V_{DD}$ )	3	3.3	3.6	V	
LNA_EN Voltage	2.8	3.1	3.3	V	
Gain	12	15	17	dB	Temp=25°C
	10	15	18	dB	All conditions
NF		2.5	3.0	dB	Temp=25°C
		2.5	4.5	dB	All conditions
Rx Port Return Loss	8	10		dB	
ANT Port Return Loss	6	10		dB	RX mode, all conditions
Input IP3		-3		dBm	Temp=25°C
Input P1dB		-13		dBm	
$I_{DD}$		13	17	mA	
	8	13	18	mA	All conditions
LNA_EN Control Current		30	100	$\mu A$	
LNA Turn On Time		200	600	nS	
Isolation					
TX-RX	32	36		dB	Measured from ANT to RX while in Tx mode
Switch Control Current - Each Line		5	10	$\mu A$	
Switching Speed		100	200	nS	
<b>Transmit Parameters @ +95°C</b>					<b><math>V_{CC} = 3.3V</math>; <math>P_{OUT} = 13dBm</math>; SW Control High: 3.1V; SW Control Low: 0.2V; PA_EN = 3.1V; Freq = 5.18GHz to 5.825GHz; Modulation MCS7 20MHz; Duty Cycle = 50%; Temp = +95°C; Unless Otherwise Noted</b>
Dynamic EVM		2	2.5	%	
Gain	21	29		dB	
Operating Current		240	270	mA	
Quiescent Current		185	215	mA	
PA_EN Current		35	110	$\mu A$	
Second Harmonic		-45	-42	dBm	$P_{OUT} = 17dBm$ , 11a 6Mbps; 100% duty cycle
Third Harmonic		-48	-42	dBm	$P_{OUT} = 17dBm$ , 11a 6Mbps; 100% duty cycle

Parameter	Specification			Unit	Condition
	Min	Typ	Max		
<b>Receive Parameters @ +95°C</b>					<b>V<sub>DD</sub> = 3.3V; SW Control High: 3.1V; SW Control Low: 0.2V; LNA_EN = 3.1V; Freq = 5.18GHz to 5.825GHz; Temp = +95°C; Unless Otherwise Noted</b>
Gain	9.5	14		dB	Gain
Noise Figure		2.5	4.6	dB	Noise Figure
RX Port Return Loss	7	10		dB	RX Port Return Loss
ANT Port Return Loss	5	10		dB	ANT Port Return Loss
Current Consumption		15	19	mA	Current Consumption
<b>ESD</b>					
Human Body Model (HBM)	1000			V	EIA/JESD22-114A; All DC pins
	500			V	EIA/JESD22-114A; All RF pins
Charge Device Model	1000			V	JESD22-C101C; All pins

## Logic Control Table

Mode	PA_EN	LNA_EN	C_RX
Standby	Low	Low	Low
802.11a/n TX	High	Low	Low
802.11a/n RX Gain	Low	High	High

Performance Plots

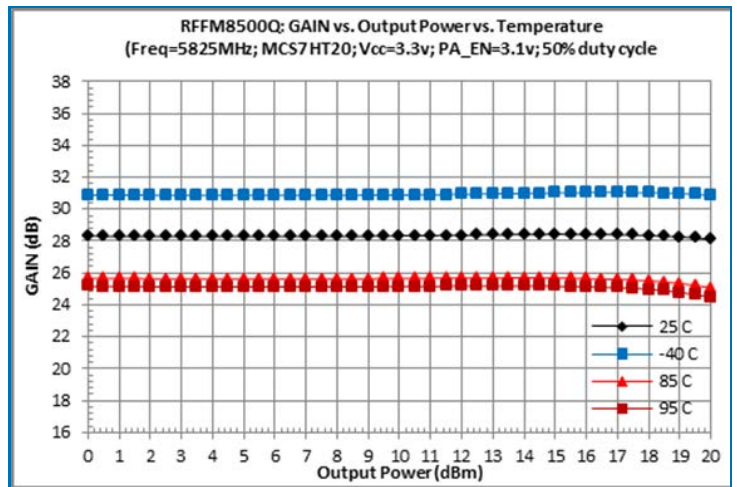
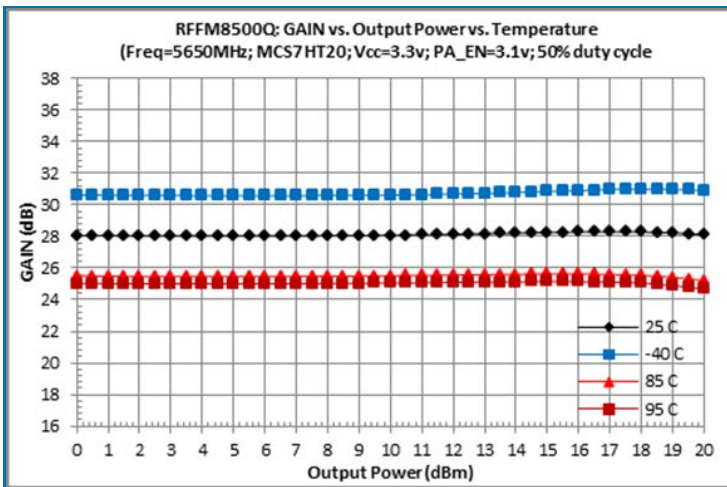
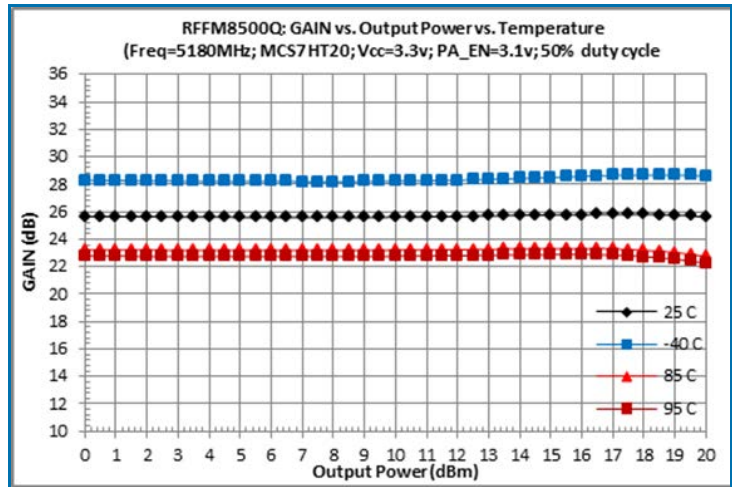
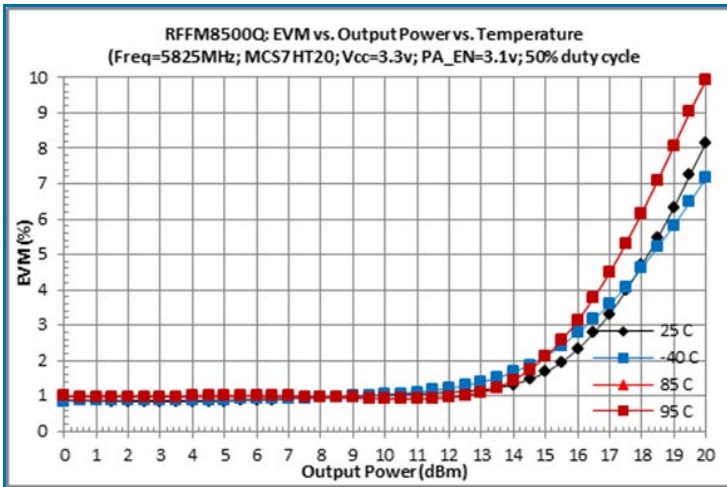
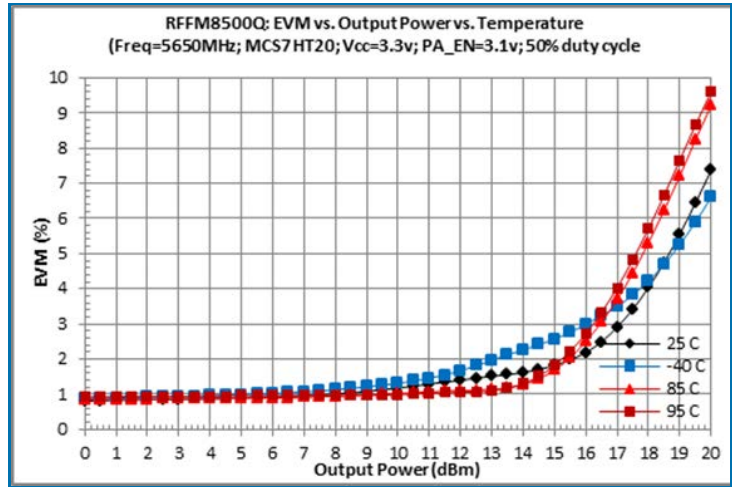
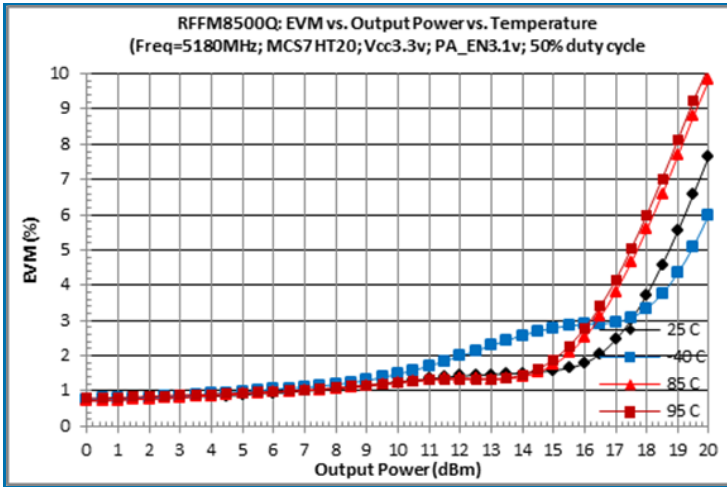

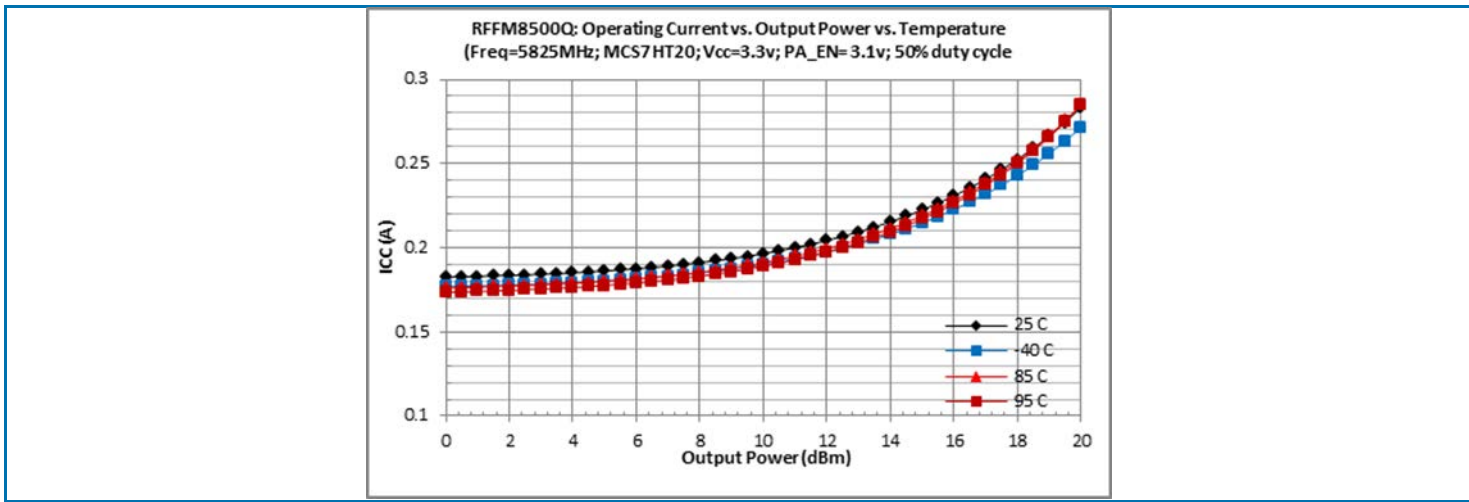
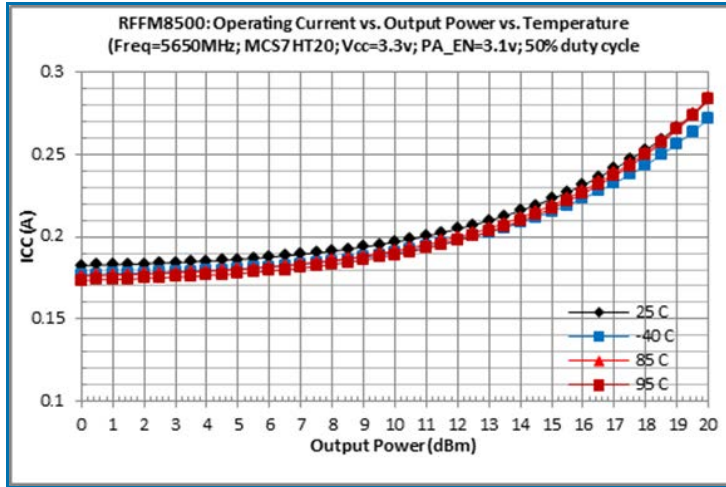
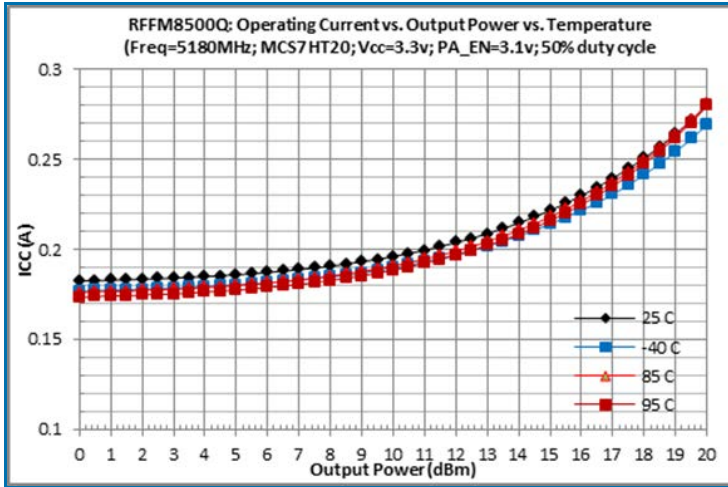

Applications Schematic

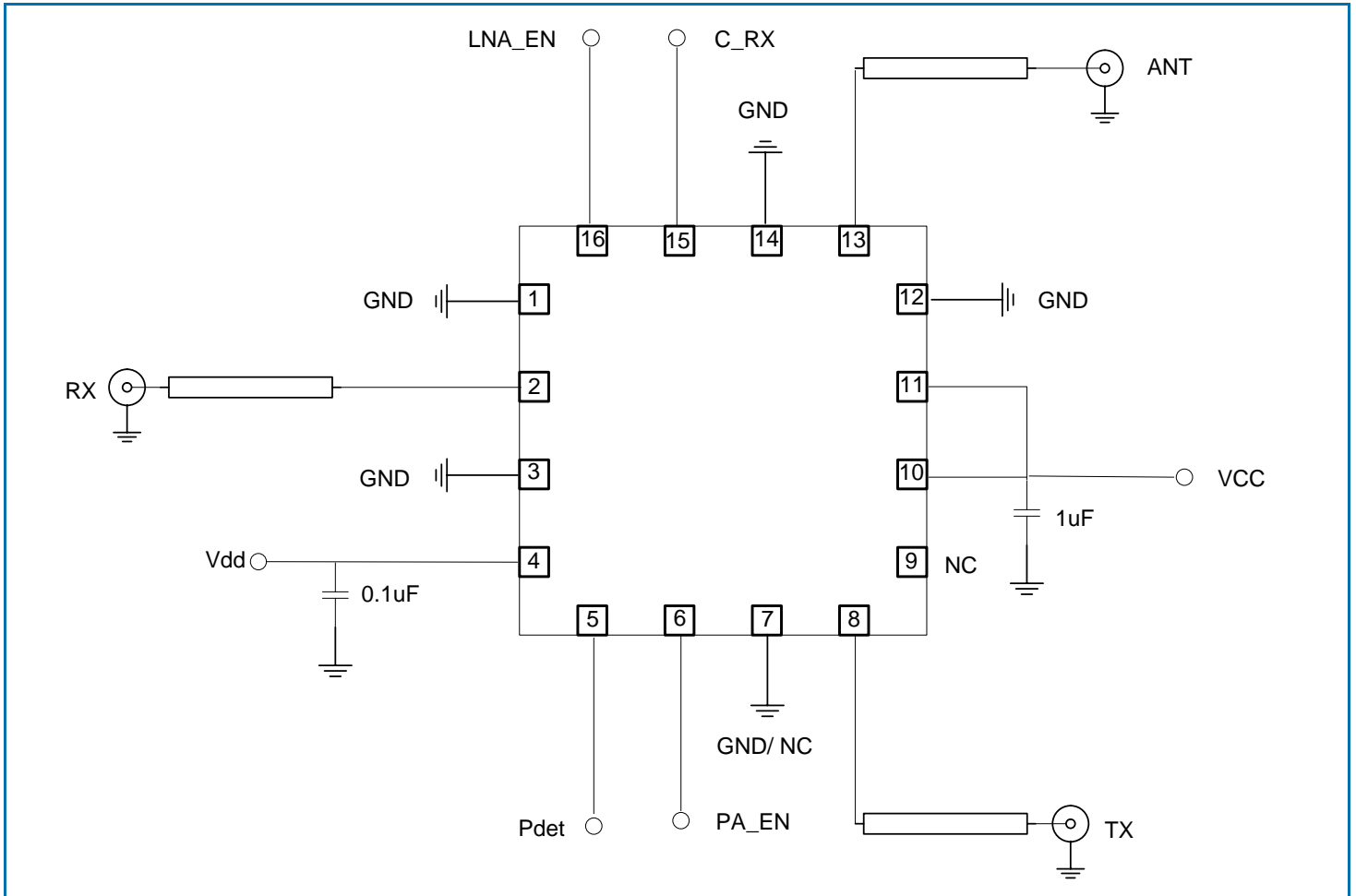

Pin Out

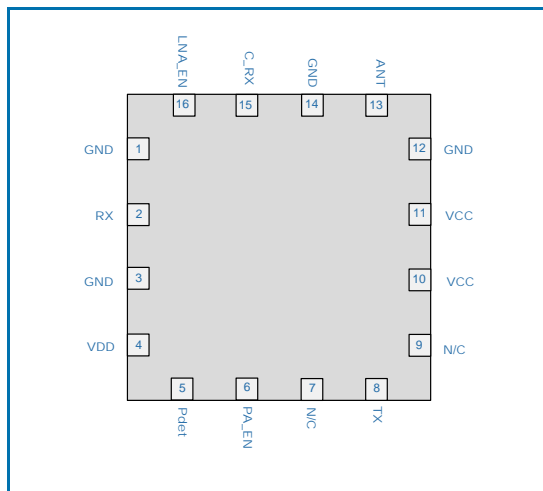

Package Drawing

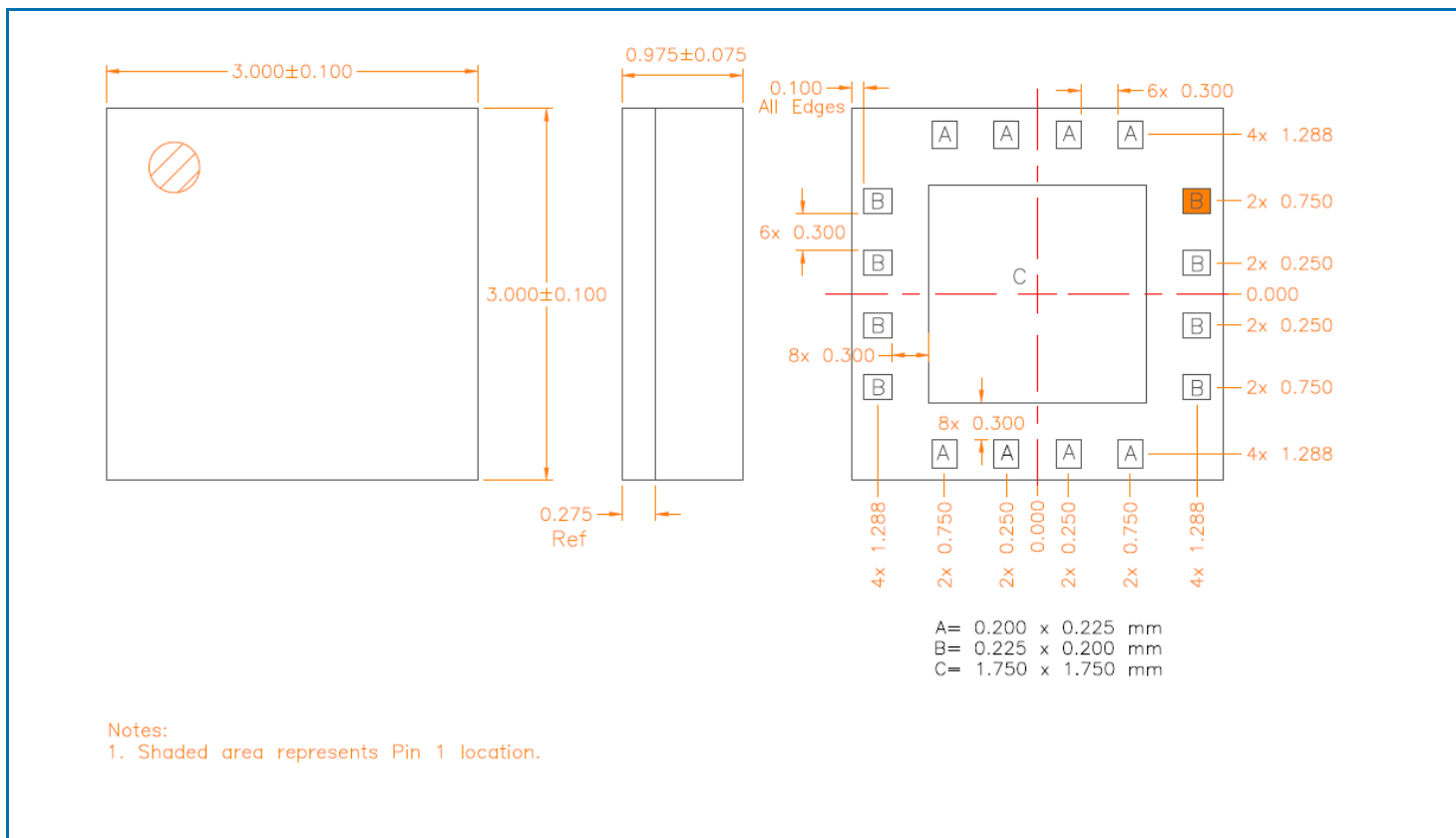



## PCB Patterns

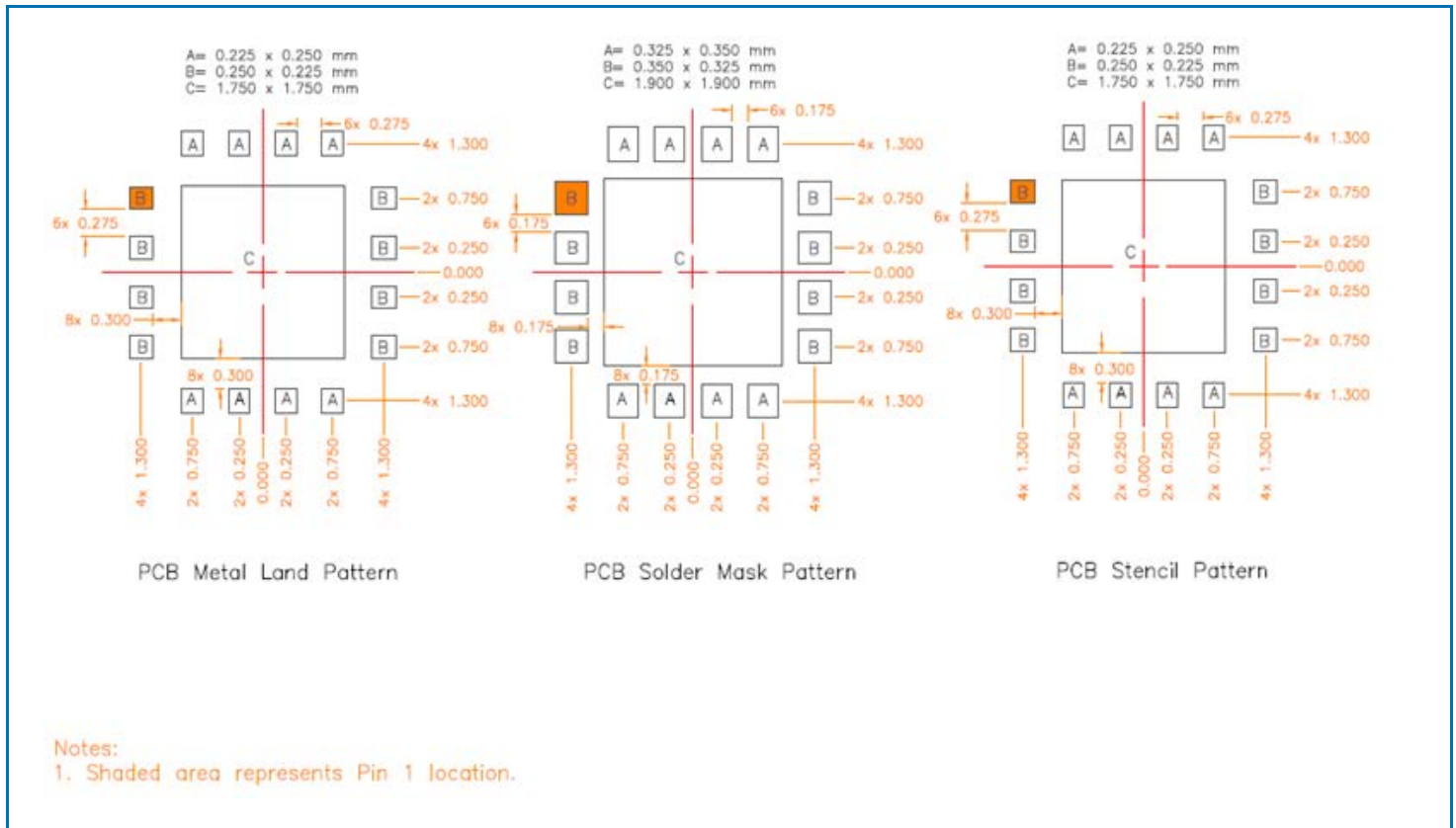

### Notes:

1. Shaded area represents Pin 1 location.
2. Thermal vias for center slug "C" should be incorporated into the PCB design. The number and size of thermal vias will depend on the application, power dissipation and electrical requirements. Example of the number and size of vias can be found on the RFMD evaluation board layout (gerber files are available upon request)

## Pin Names and Descriptions

Pin	Name	Description
1	GND	Ground connection.
2	RX	RF output port for the 802.11a/n LNA. Input is matched to 50Ω and DC block is provided.
3	GND	Ground connection.
4	VDD	Supply voltage for the LNA. See applications schematic for biasing and bypassing components.
5	PDET	Power detector voltage for TX section. P <sub>DET</sub> voltage varies with output power. May need external capacitor for noise decoupling.
6	PA_EN	Control voltage for the PA and TX switch. See Logic Control Table for proper settings.
7	NC	Not connected.
8	TX	RF input port for the 802.11a/n PA. Input is matched to 50Ω and DC block is provided.
9	NC	Not connected.
10	VCC	Supply voltage for the PA. See applications schematic for biasing and bypassing components.
11	VCC	Supply voltage for the PA. See applications schematic for biasing and bypassing components.
12	GND	Ground connection.
13	ANT	RF bidirectional antenna port matched to 50Ω and is DC blocked internally.
14	GND	Ground connection.
15	C_RX	Receive switch control pin. See Logic Control Table for proper level.
16	LNA_EN	Control voltage for the LNA. See Logic Control Table for proper settings.
Pkg Base	GND	Ground connection.