



Features

- Low Cost
- Broadband Gain
- Internally Matched
- Internal Active Bias
- No Dropping Resistor
- Single Supply 5V Operation
- HBM ESD Level >1000V

Applications

- Transceiver IF Amplifier
- LO Buffer Amplifier
- Cellular, PCS, GSM, UMTS, LTE, TD-SCDMA
- Wireless Data, Satellite Terminals

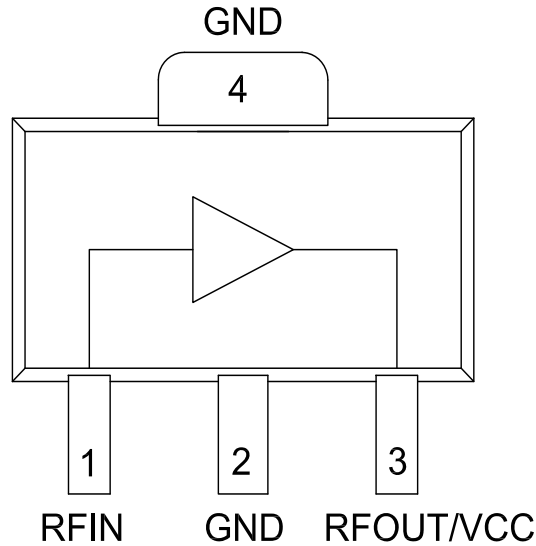

Functional Block Diagram

Product Description

The RFGA0014 is a high performance InGaP HBT MMIC amplifier. The RFGA0014's internal active bias circuitry allows the amplifier to operate directly from a 5V supply and provides stable current over temperature and process Beta variation. This Darlington amplifier is internally matched to 50Ω making it ideal for applications requiring small footprints and minimal external components.

Ordering Information

RFGA0014SR	7" Sample reel with 100 pieces
RFGA0014SQ	Sample bag with 25 pieces
RFGA0014TR13	13" Reel with 2500 pieces
RFGA0014PCK-410	50MHz to 500MHz PCBA with 5-piece sample bag

Absolute Maximum Ratings

Parameter	Rating	Unit
Supply Voltage (V_{CC})	6.0	V
Device Current (I_{CC})	130	mA
CW Input Power, 2:1 Output VSWR	20	dBm
CW Input Power, 10:1 Output VSWR	15	dBm
Operating Junction Temperature (T_J)	150	°C
Operating Temperature Range (T_L)	-40 to +85	°C
Storage Temperature	-55 to +150	°C
ESD Rating - Human Body Model	1C (1000V)	
Moisture Sensitivity Level	MSL-2	

NOTES:

1. The maximum rating must all be met simultaneously.
2. $P_{DISS} = P_{DC} + P_{RFIN} - P_{RFOUT}$
3. $T_J = T_L + P_{DISS} * R_{TH}$



Caution! ESD sensitive device.

Exceeding any one or a combination of the Absolute Maximum Rating conditions may cause permanent damage to the device. Extended application of Absolute Maximum Rating conditions to the device may reduce device reliability. Specified typical performance or functional operation of the device under Absolute Maximum Rating conditions is not implied.

The information in this publication is believed to be accurate and reliable. However, no responsibility is assumed by RF Micro Devices, Inc. ("RFMD") for its use, nor for any infringement of patents, or other rights of third parties, resulting from its use. No license is granted by implication or otherwise under any patent or patent rights of RFMD. RFMD reserves the right to change component circuitry, recommended application circuitry and specifications at any time without prior notice.



RFMD Green: RoHS compliant per EU Directive 2002/95/EC, halogen free per IEC 61249-2-21, < 1000ppm each of antimony trioxide in polymeric materials and red phosphorus as a flame retardant, and <2% antimony in solder.

Nominal Operating Parameters

Parameter	Specification			Unit	Condition
	Min.	Typ.	Max.		
Input Power (P_{IN})			12	dBm	Max recommended continuous input power, $V_{CC} < 5.0V$, Load VSWR < 2:1
Gain		15.2		dB	150MHz
		15.1		dB	250MHz
	13.3	14.8	16.3	dB	450MHz
OIP3		41.0		dBm	150MHz (3dBm/Tone, 1MHz spacing)
		39.3		dBm	250MHz (3dBm/Tone, 1MHz spacing)
	35.3	37.8		dBm	450MHz (3dBm/Tone, 1MHz spacing)
P1dB		18.9		dBm	150MHz
		18.8		dBm	250MHz
	17.5	19.0		dBm	450MHz
Input Return Loss		18		dB	
Output Return Loss		15.5		dB	
Isolation		18		dB	
Noise Figure		4.0		dB	
Operating Current (Quiescent)		82	96	mA	At $V_{CC} = 5.0V$
Operating Current			110	mA	Max recommended voltage for continuous operation
Operating Voltage (V_{CC})		5.0	5.25	V	Max recommended voltage for continuous operation
Thermal Resistance (R_{TH})		98		°C/W	At quiescent current, no RF, $V_{CC} = 5.0V$

Typical Performance: 50MHz to 500MHz Application Circuit

Input Return Loss versus Frequency

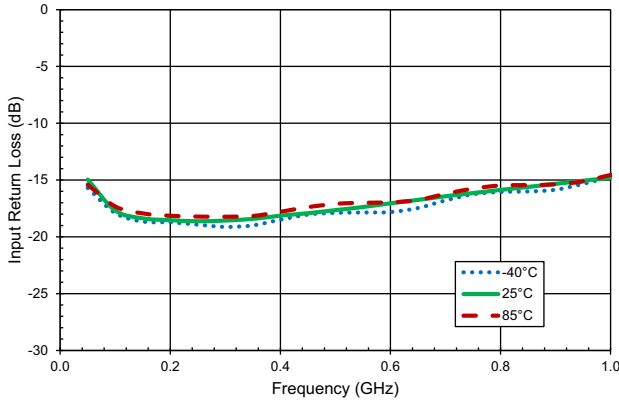

Gain versus Frequency

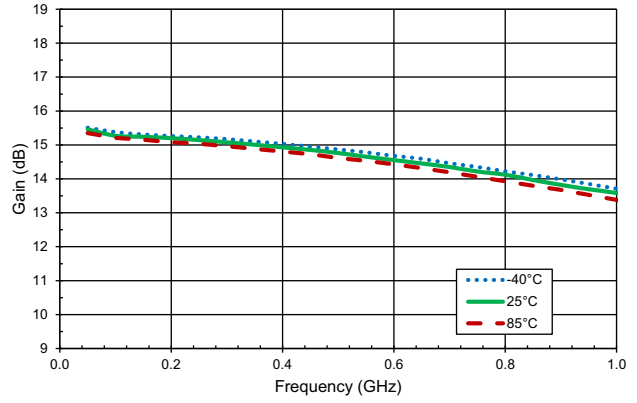

Isolation versus Frequency

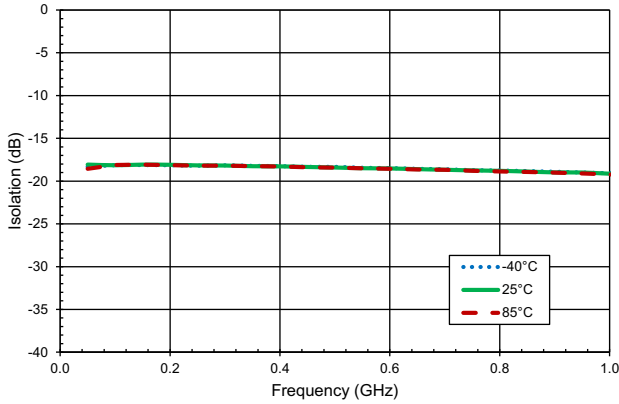

Output Return Loss versus Frequency

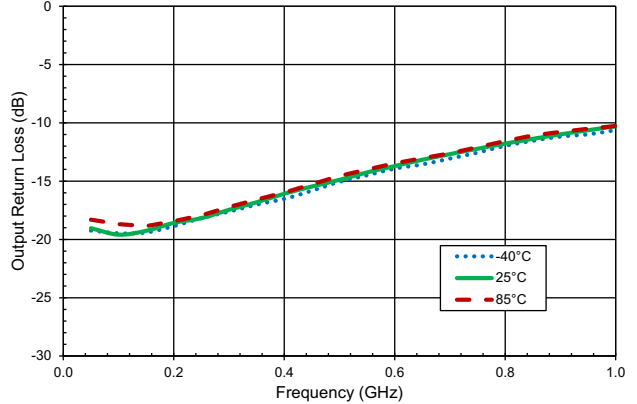

OIP3 versus Frequency

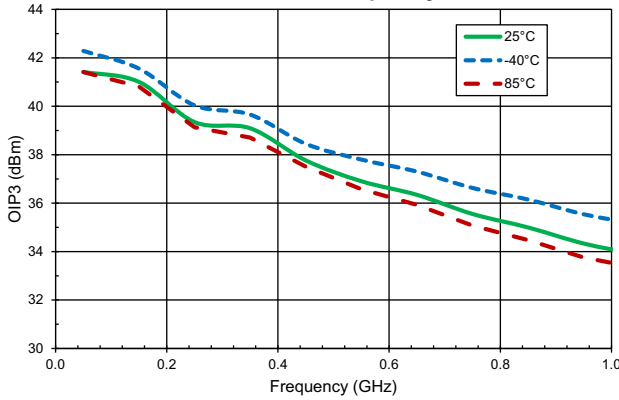

P1dB versus Frequency

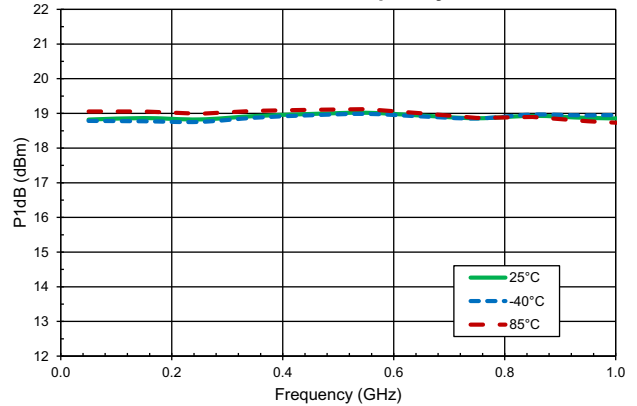

Typical Performance: 50MHz to 500MHz Application Circuit

Noise Figure versus Frequency

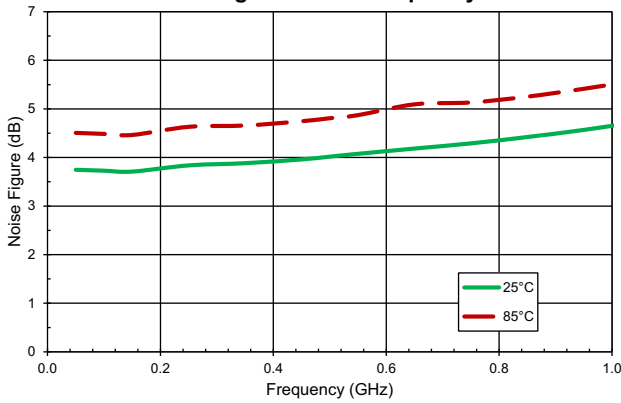

Current versus Voltage

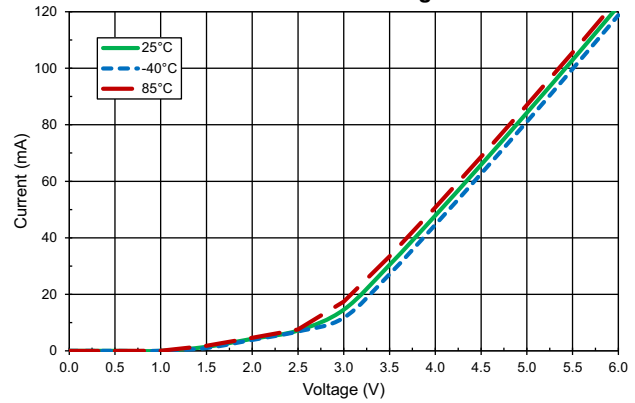

P_{OUT} and Current versus Input Power (150MHz)

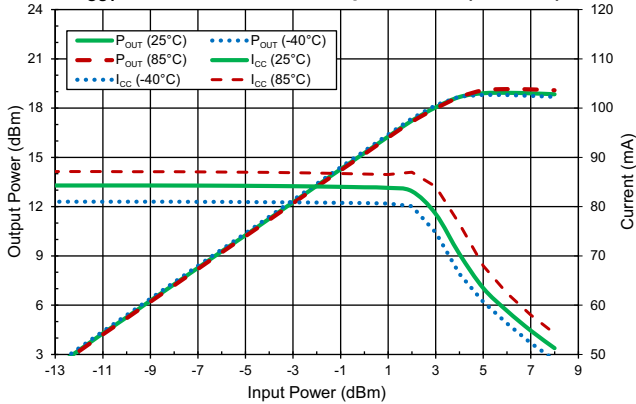

P_{OUT} and Current versus Input Power (450MHz)

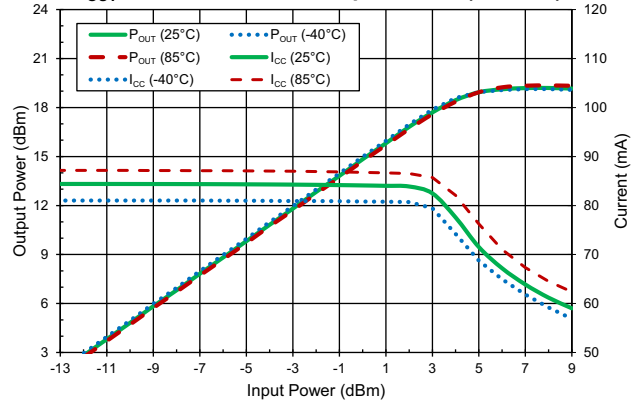

P_{OUT} and Current versus Input Power (850MHz)

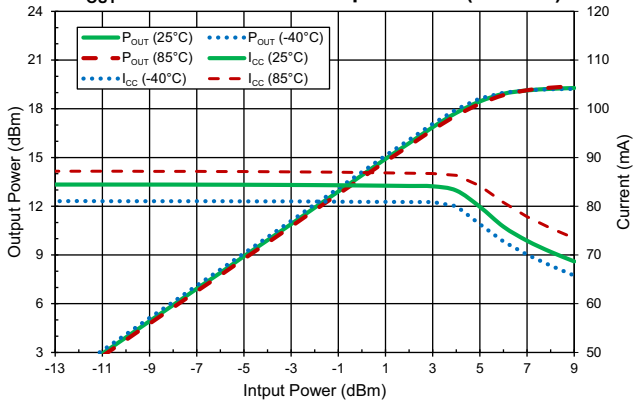

Large Signal Current versus Frequency (25°C, 50Ω)

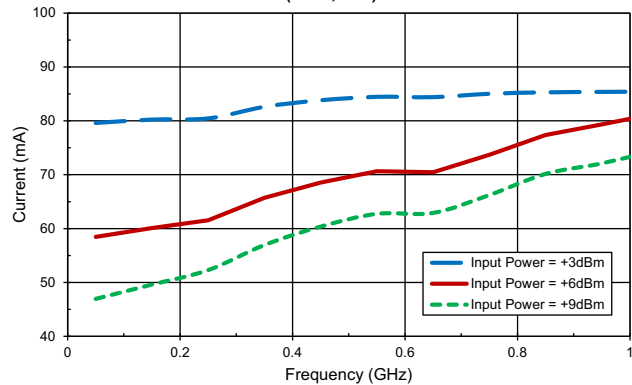

Evaluation Board Schematic
50MHz to 500MHz Application Circuit

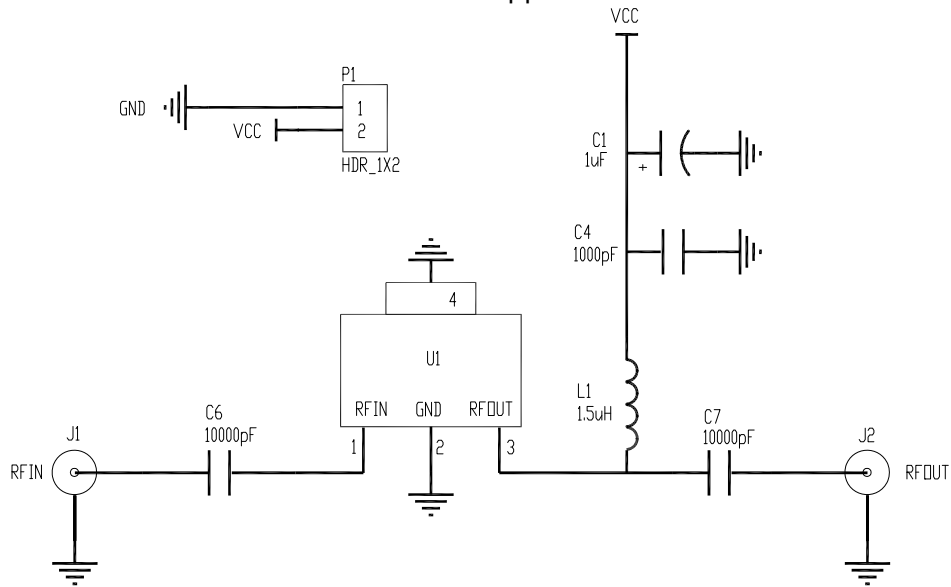

Evaluation Board Bill of Materials (BOM)

50MHz to 500MHz Application Circuit

Description	Reference Designator	Manufacturer	Manufacturer's P/N
GA2054 Evaluation Board			GA2054-410(A)
CAP, 1uF, 20%, 25V, TANT-A	C1	AVX Corporation	TAJA105M025
CAP, 1000pF, 10%, 50V, X7R, 0402	C4	Taiyo Yuden (USA), Inc.	RM UMK105BJ102KV-F
CAP, 10000pF, 10%, 16V, X7R, 0402	C6-C7	Taiyo Yuden (USA), Inc.	RM EMK105BJ103KV-F
IND, 1.5uH, 5%, W/W, 0805	L1	Coilcraft, Inc.	0805LS-152XJLB
CONN, SMA, END LNCH, FLT, 0.062"	J1-J2	Johnson Components, Inc.	142-0701-821
CONN, HDR, ST, PLRZD, 2-PIN, 0.100"	P1	ITW Pancon	MPSS100-2-C
InGaP HBT Darlington Amp	U1	RFMD	GA0014
Do Not Place	C2-C3, C5, R1		

Evaluation Board Assembly Drawing

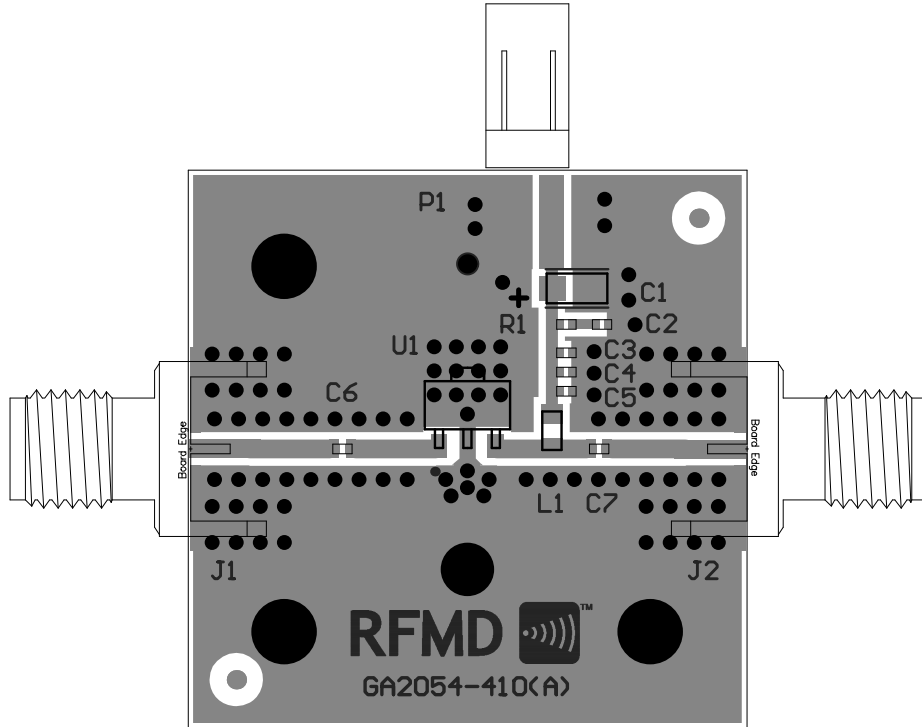

Pin Names and Descriptions

Pin	Name	Description
1	RF IN	RF Input. External DC block is required.
2	GND	DC and RF Ground
3	RF OUT/VCC	RF Output, Device Collector
4	GND	DC and RF Ground. Must be soldered to EVB ground plane over a bed of vias for thermal and RF performance.

Branding Diagram

Trace Code to be assigned by the assembly SubCon.

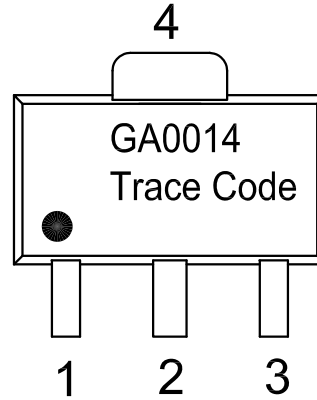

Package Drawing

Dimensions in millimeters [inches]

Refer to drawing posted at www.rfmd.com for tolerances.

