

RFLA1038

Variable Gain Low Noise High Linearity Amplifier
1710MHz to 1785MHz

The RFLA1038 is an analog-controlled voltage variable gain amplifier featuring high linearity and very low noise figure. This LNA with bypass mode and variable attenuator provides a minimum of 35dB of dynamic range. The RFLA1038 has a 3.3V control range with maximum gain at 0V. The LNA is temperature compensated to reduce gain variation. Noise figure of 0.8dB and IIP3 of 7dBm make this component ideal for receiver input lineups. The RFLA1038 is packaged in a small 8.0mm x 8.0mm leadless MCM that is internally matched to 50Ω on all RF ports.



Package: MCM, 16-pin,
8.0mm x 8.0mm

Features

- 1710MHz to 1785MHz Operation
- Internally Matched to 50Ω on All RF Ports
- Analog Voltage Variable Attenuator with 3.3V Control Range
- Bypass Mode of LNA for High Dynamic Range
- Max Gain = 35dB Minimum
- Noise Figure of 0.8dB Typical
- Gain Control Range >35dB
- High IIP3 = 7dBm
- Single +5V Supply

Applications

- Cellular Base Station, Remote Radio Heads
- Active Antenna Radios
- 3G, LTE Infrastructure
- Low Noise, Variable Gain with High Linearity

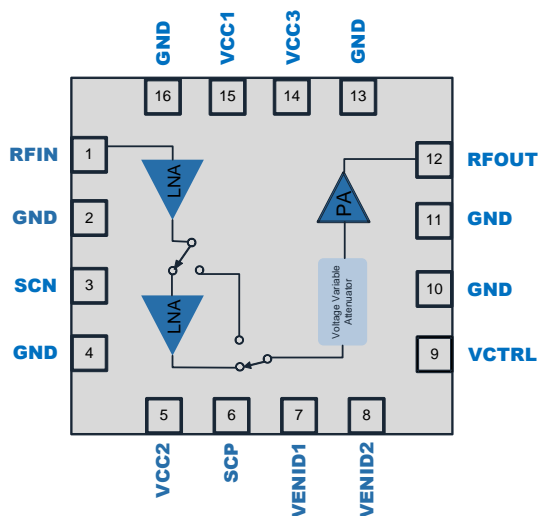

Functional Block Diagram

Ordering Information

RFLA1038SQ	Sample bag with 25 pieces
RFLA1038SR	7" Reel with 100 pieces
RFLA1038TR13	13" Reel with 2500 pieces
RFLA1038PCK-410	1710MHz to 1785MHz PCBA with 5-piece sample bag

Absolute Maximum Ratings

Parameter	Rating	Unit
Control Voltage	+5.5	V
Supply Voltage	+5.5	V
DC Supply Current	400	mA
Power Dissipation	2000	mW
Max RF Input Power	27	dBm
Storage Temperature Range	-40 to +150	°C
ESD Rating - Human Body Model (HBM)	1000 (Class 1C)	V
Moisture Sensitivity Level	MSL3	



Caution! ESD sensitive device.



RoHS (Restriction of Hazardous Substances): Compliant per EU Directive 2011/65/EU.

Exceeding any one or a combination of the Absolute Maximum Rating conditions may cause permanent damage to the device. Extended application of Absolute Maximum Rating conditions to the device may reduce device reliability. Specified typical performance or functional operation of the device under Absolute Maximum Rating conditions is not implied.

Recommended Operating Condition

Parameter	Specification			Unit
	Min	Typ	Max	
Operating Temperature Range	-40		+85	°C
Operating Junction Temperature			+160	°C
Supply Voltage	4.75	5	5.25	V

Nominal Operating Parameters

Parameter	Specification			Unit	Condition
	Min	Typ	Max		
High Gain Mode Performance					Temp = 25°C, V_{CC} = 5V, Standard Application Circuit
Operating Frequency Range	1710		1785	MHz	
Max Gain	36.5	38	41	dB	Attenuation = Minimum, VVA_CV = 0V
Gain Flatness		0.49	0.9	dB	Gain Range 35dB to 19dB
Min Gain	10	14		dB	
Output IP3 (Max Gain)		39.5		dBm	Attenuation = Minimum, VVA_CV = 0V
Input IP3	1	7		dBm	30dB to 35dB Gain
	3	10		dBm	19dB to 29dB Gain
Output P1dB (Max Gain)		25.5		dBm	Attenuation = Minimum, VVA_CV = 0V
Input P1dB	-14	-6.5		dBm	30dB to 35dB Gain
	-7	-5		dBm	19dB to 29dB Gain
Noise Figure		0.8		dB	Attenuation = Minimum, VVA_CV = 0V
Input Return Loss		-31	-20	dB	19dB to 35dB Gain
Output Return Loss		-19	-15	dB	

Parameter	Specification			Unit	Condition
	Min	Typ	Max		
Low Gain Mode Performance					Temp = 25°C, V_{CC} = 5V, Standard Application Circuit
Operating Frequency Range	1710		1785	MHz	
Max Gain	20.1	23.5	25	dB	Attenuation = Minimum, VVA_CV = 0V
Gain Flatness		0.31	0.9	dB	Gain range 18dB to 3dB
Min Gain	-10	-3	3	dB	
Output IP3 (Max Gain)		40		dBm	Max Gain, Attenuation = Minimum, VVA_CV = 0V
Input IP3	14	22.5		dBm	12dB to 18dB Gain
	18	26		dBm	3dB to 11dB Gain
Output P1dB (Max Gain)		26		dBm	Attenuation = Minimum, VVA_CV = 0V
Input P1dB	4	11		dBm	12dB to 18dB Gain
	8	13		dBm	6dB to 11dB Gain
	10.2	13		dBm	3dB to 5dB Gain
Noise Figure (Max Gain)		1.8		dB	Attenuation = Minimum, VVA_CV = 0V
Input Return Loss		-26	-20	dB	3dB to 18dB Gain
Output Return Loss		-25	-15	dB	
Power Supply					
VCTRL Voltage	0		3.3	V	
Logic High	2		5	V	
Logic Low	0		1	V	
Thermal Resistance		35.5		°C/W	85°C at 5V
Current					
Supply Current	250	275	320	mA	HG Mode
Current ¹	250	275	320	mA	LG Mode 1
Current ²	165	190	235	mA	LG Mode 2

Notes:

1. LG mode with 2nd LNA bypass VCC still applied
2. LG mode with 2nd LNA bypass VCC disabled

Truth Table

	SC_N	SC_P
High Gain	0	1
Low Gain	1	0

Typical Performance: T = 25°C, V_{DD} = 5V unless otherwise noted

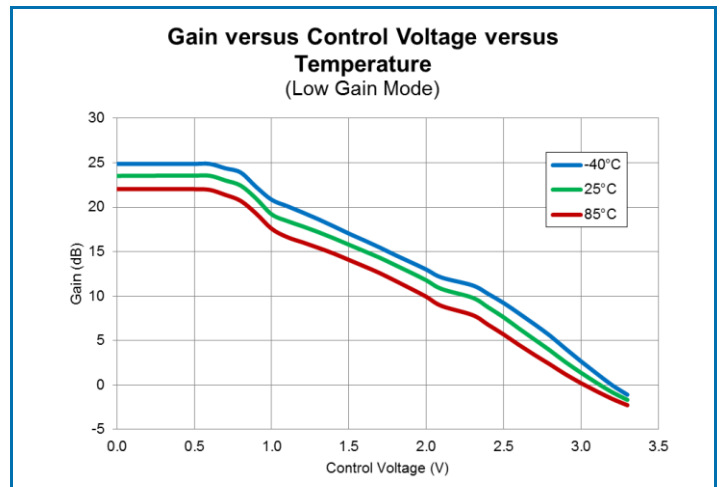
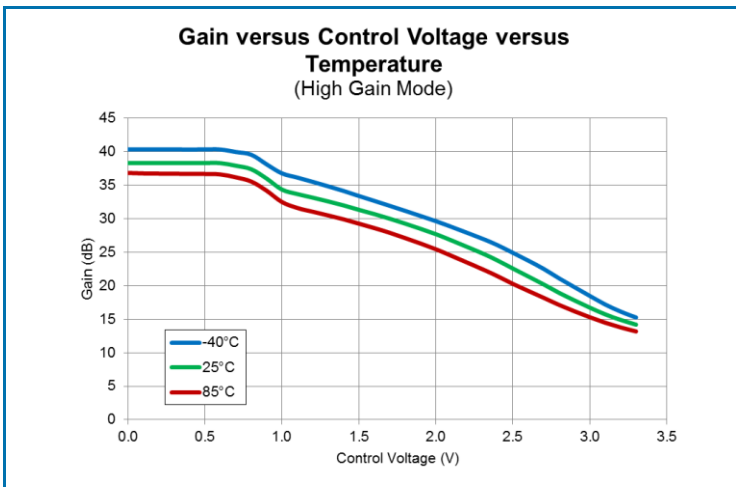
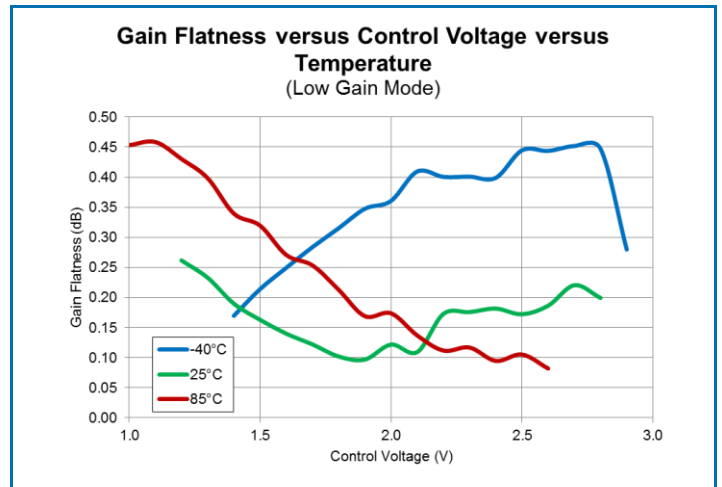
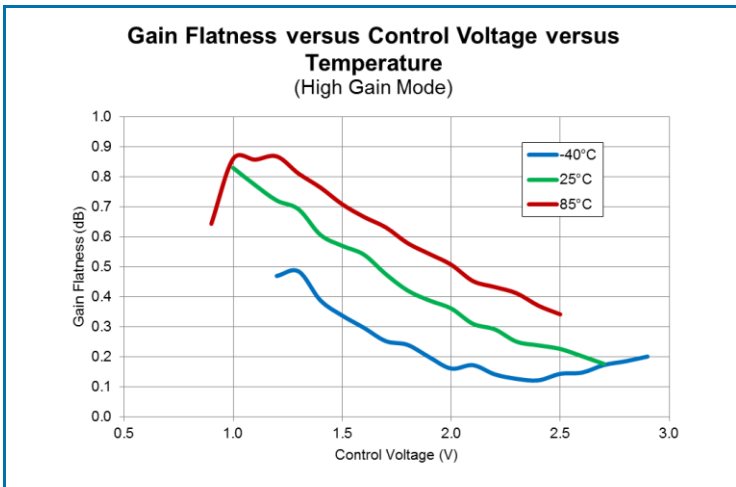
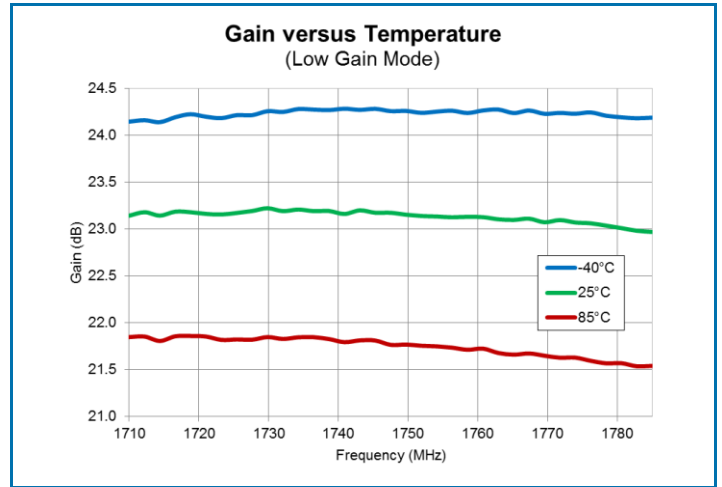
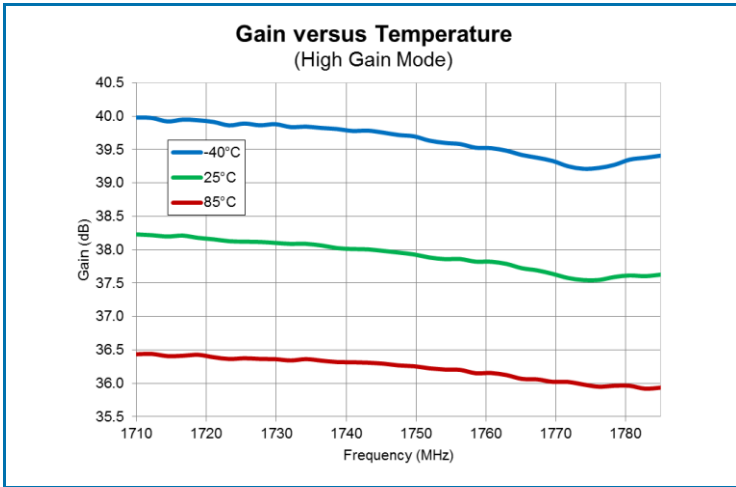

Typical Performance: T = 25°C, V_{DD} = 5V unless otherwise noted

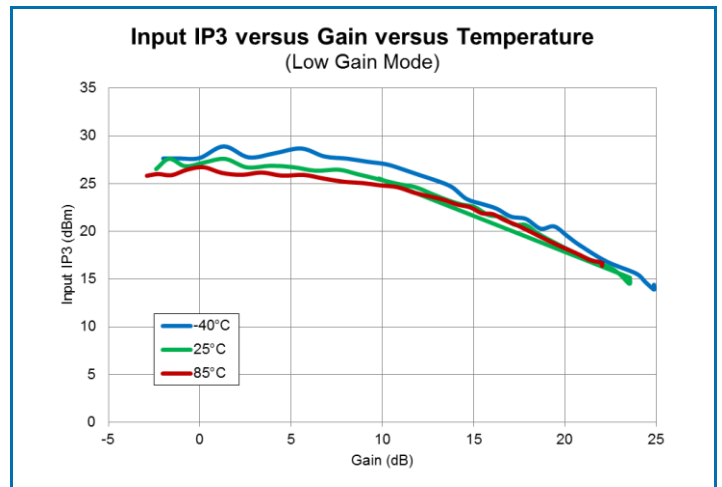
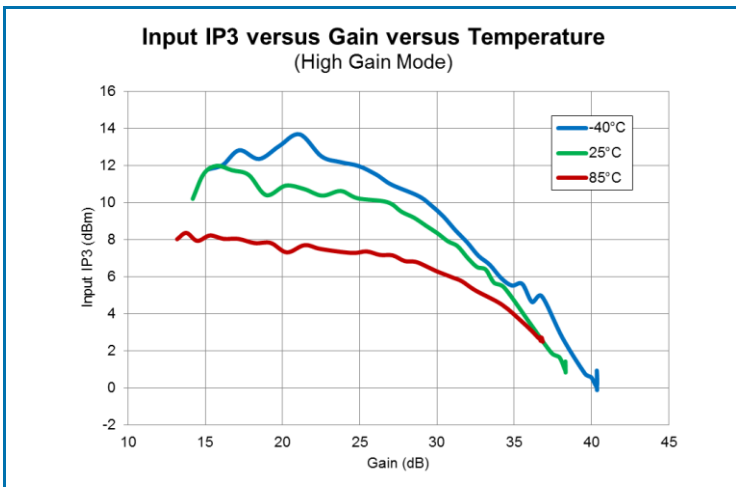
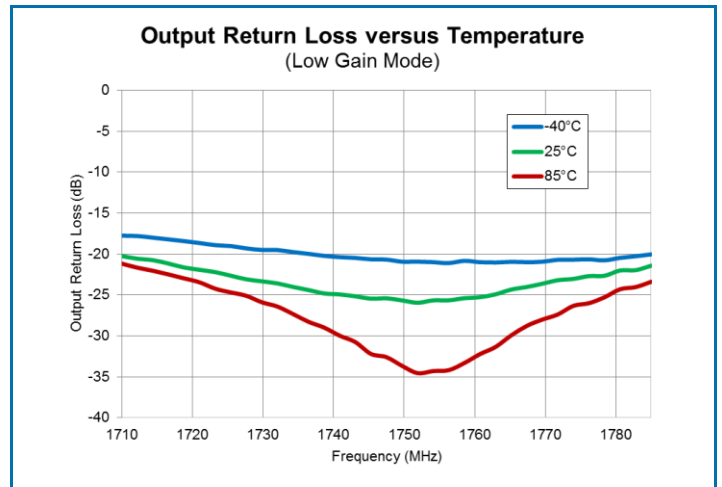
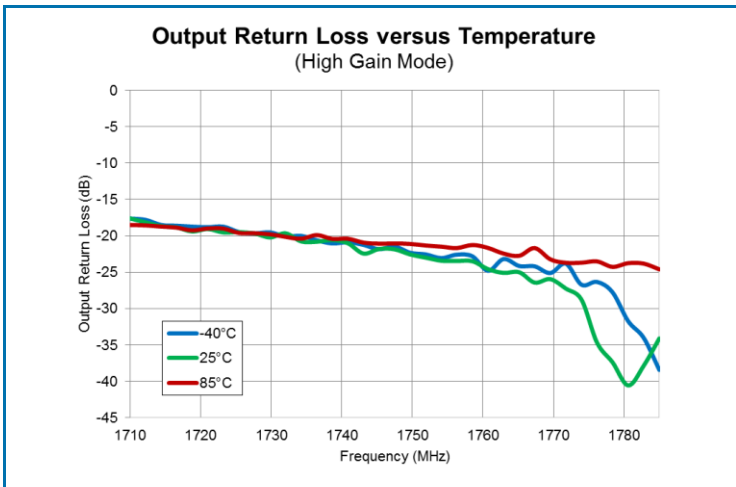
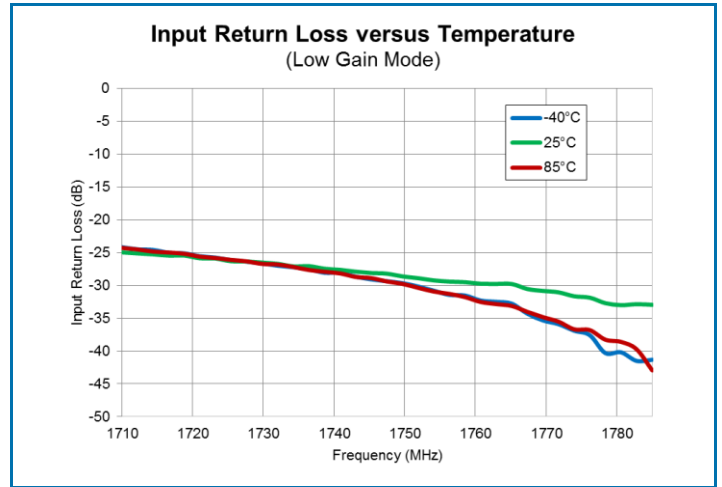
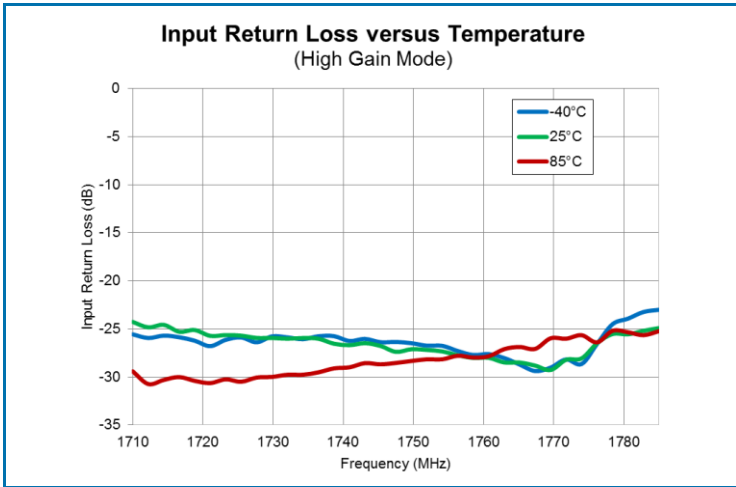

Typical Performance: T = 25°C, V_{DD} = 5V unless otherwise noted

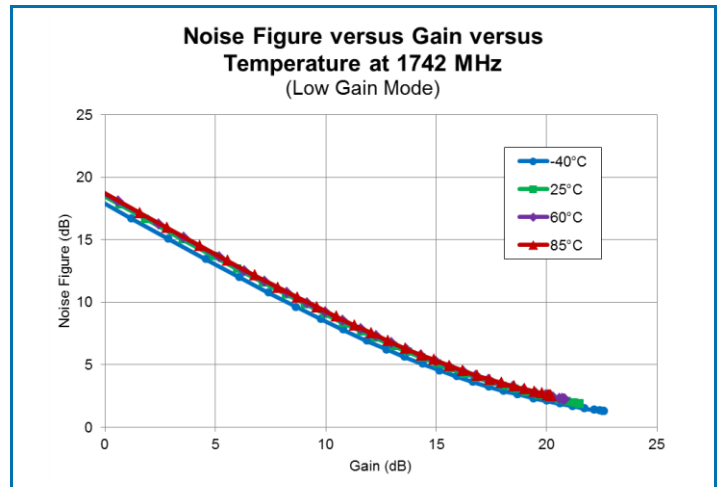
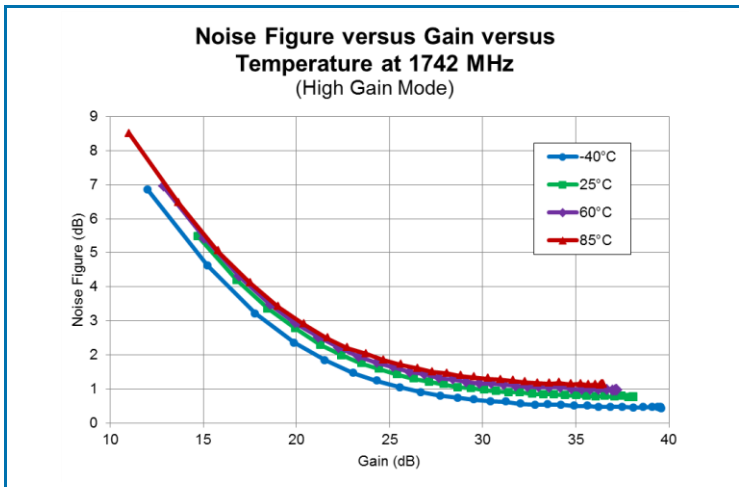
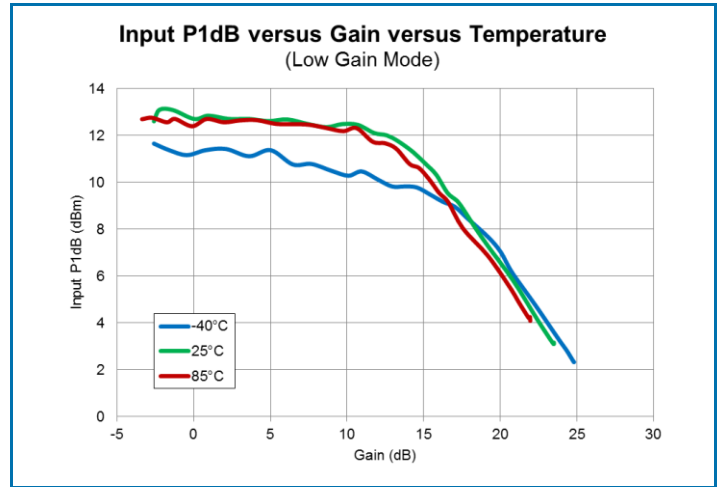
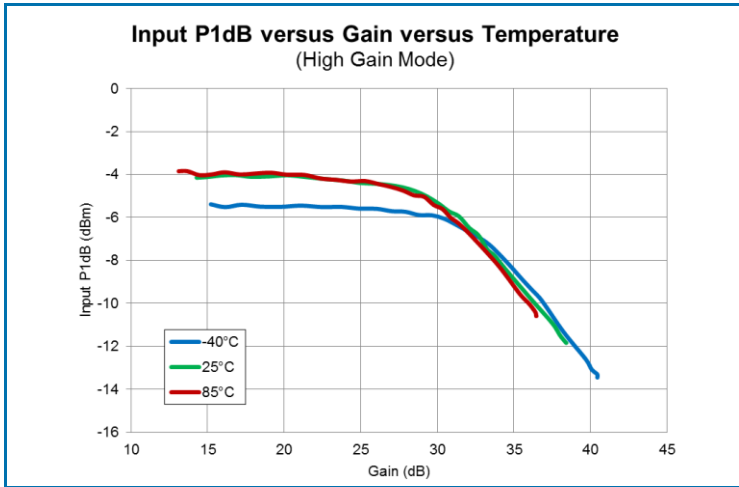

Evaluation Board Bill of Materials (BOM) 1710MHz to 1785MHz Application Circuit

Description	Reference Designator	Manufacturer	Manufacturer's P/N
Evaluation Board		DDI	RFLA1018410(E)
CAP, 0.1 μ F, 10%, 16V, X7R, 0402	C1, C3, C5-C6, C8-C9	Murata Electronics	GRM155R71C104KA88D
Do Not Place	C2, C4, C7		
CONN, SMA, END LNCH, UNIV, HYB MNT, FLT	J1-J2	Heilind Electronics	PER MAT-21-1038
RES, 0 Ω , 0402	R1-R2	Kamaya, Inc.	RMC1/165SJPTH
CONN, HDR, ST, PLRZD, 9-PIN	P1	ITW Pancon	MPSS100-9-C
RFLA1038 Module	U1	RFMD	RFLA1038

Evaluation Board Assembly Drawing

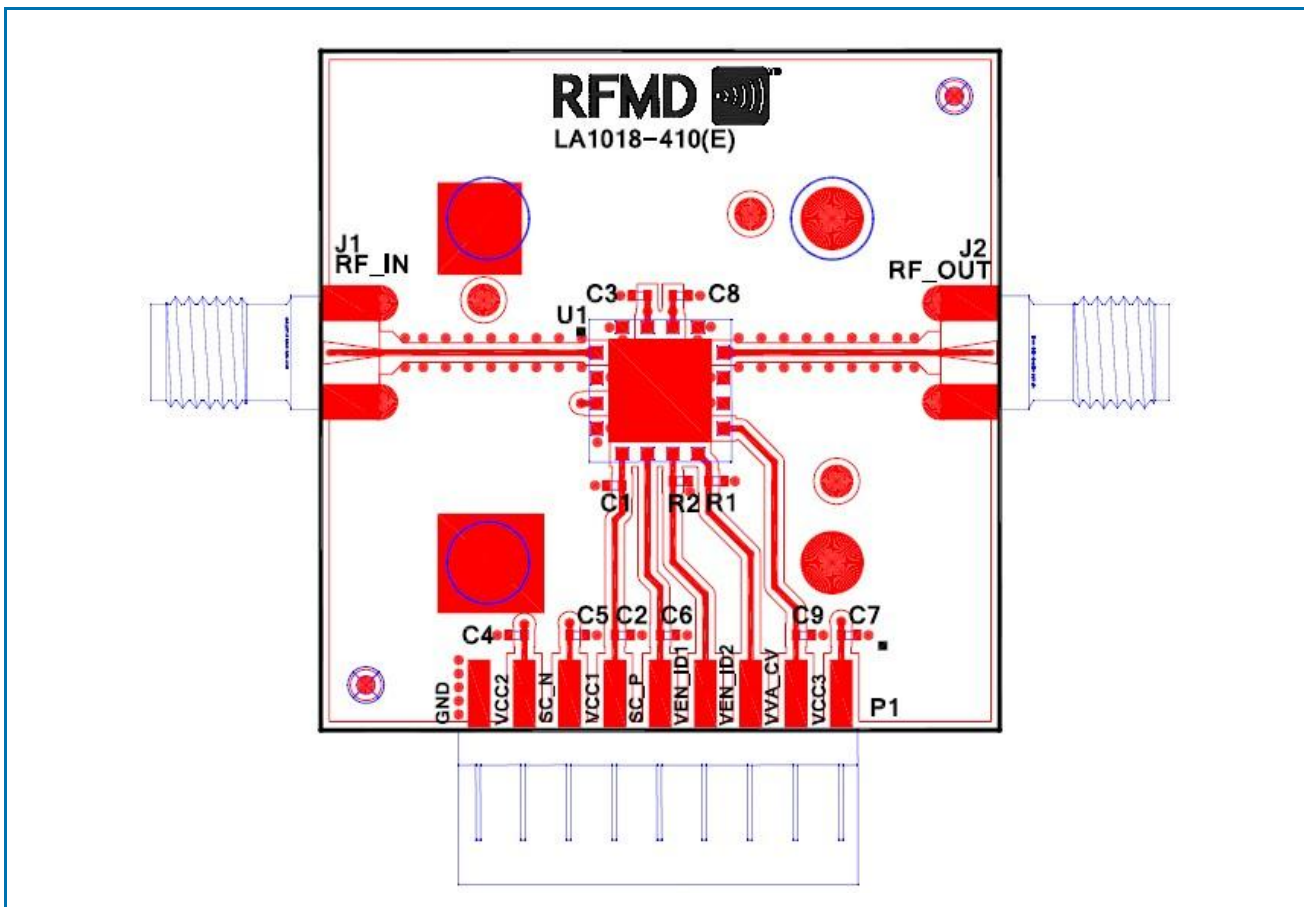

Pin Names and Descriptions

Pin	Name	Description
1	RFIN	RF Input; internally 50Ω matched and DC blocked
2	GND	Connect to low inductive path to ground
3	SCN	Switch Control Line; see truth table
4	GND	Connect to low inductive path to ground
5	VCC2	VCC Supplied; 0.1μF decoupled, supply voltage to 2 nd stage LNA; disable VCC supply in bypass mode to save DC current
6	SCP	Switch Control Line; see truth table
7	VENID1	Pin grounded in module
8	VENID2	Pin grounded in module
9	VCTRL	Voltage Variable Attenuator Control Line; max gain 0V
10	GND	Connect to low inductive path to ground
11	GND	Connect to low inductive path to ground
12	RFOUT	RF Output; internally 50Ω matched and DC blocked
13	GND	Connect to low inductive path to ground
14	VCC3	VCC Supply; 0.1μF decoupling internal; supply voltage to stage 3 amplifier
15	VCC1	VCC Supply; 0.1μF decoupling internal; supply voltage to 1 st stage amplifier
16	GND	Connect to low inductive path to ground

Package Outline Drawing (Dimensions in millimeters)

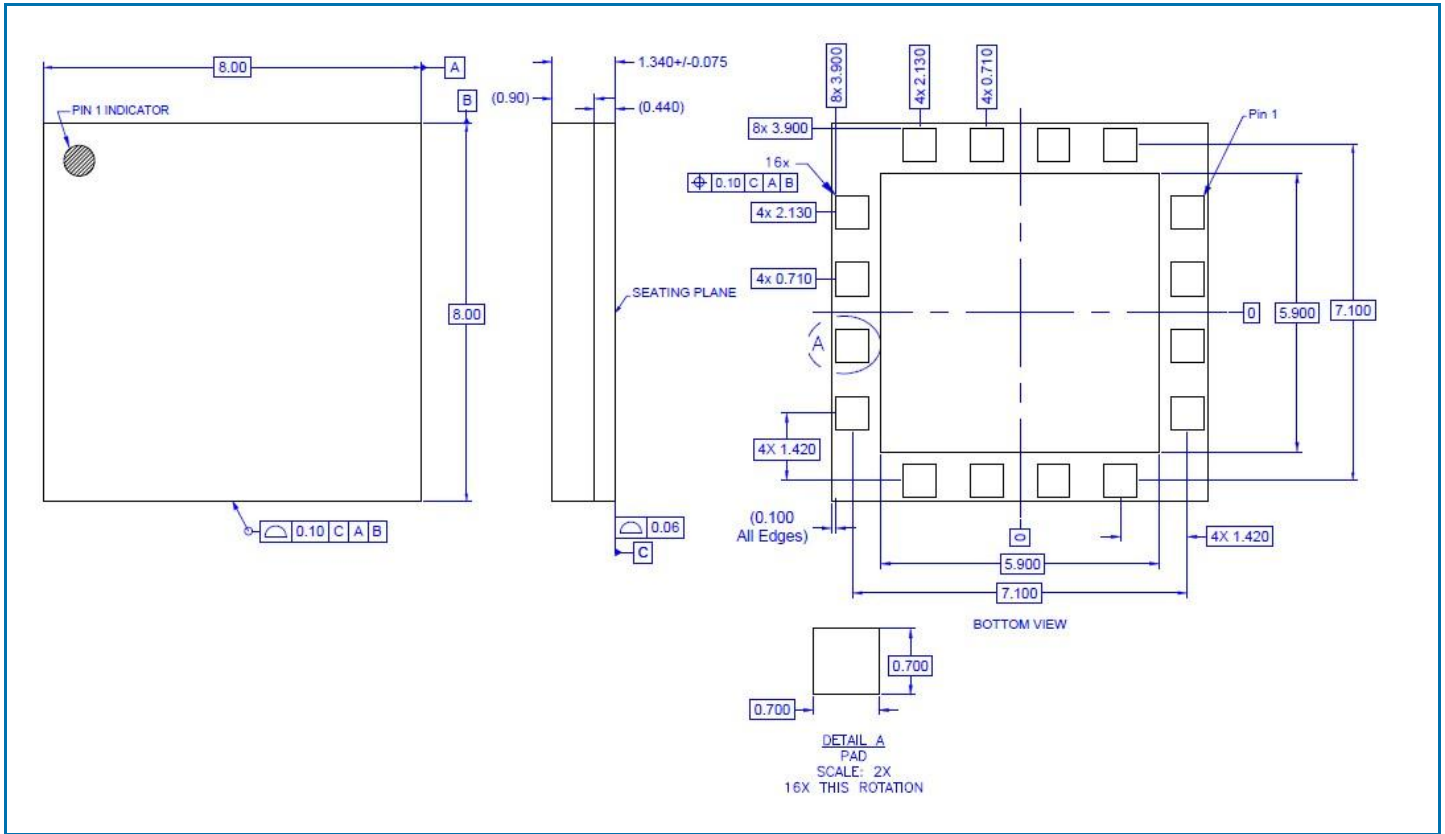

PCB Stencil Drawing (Dimensions in millimeters)

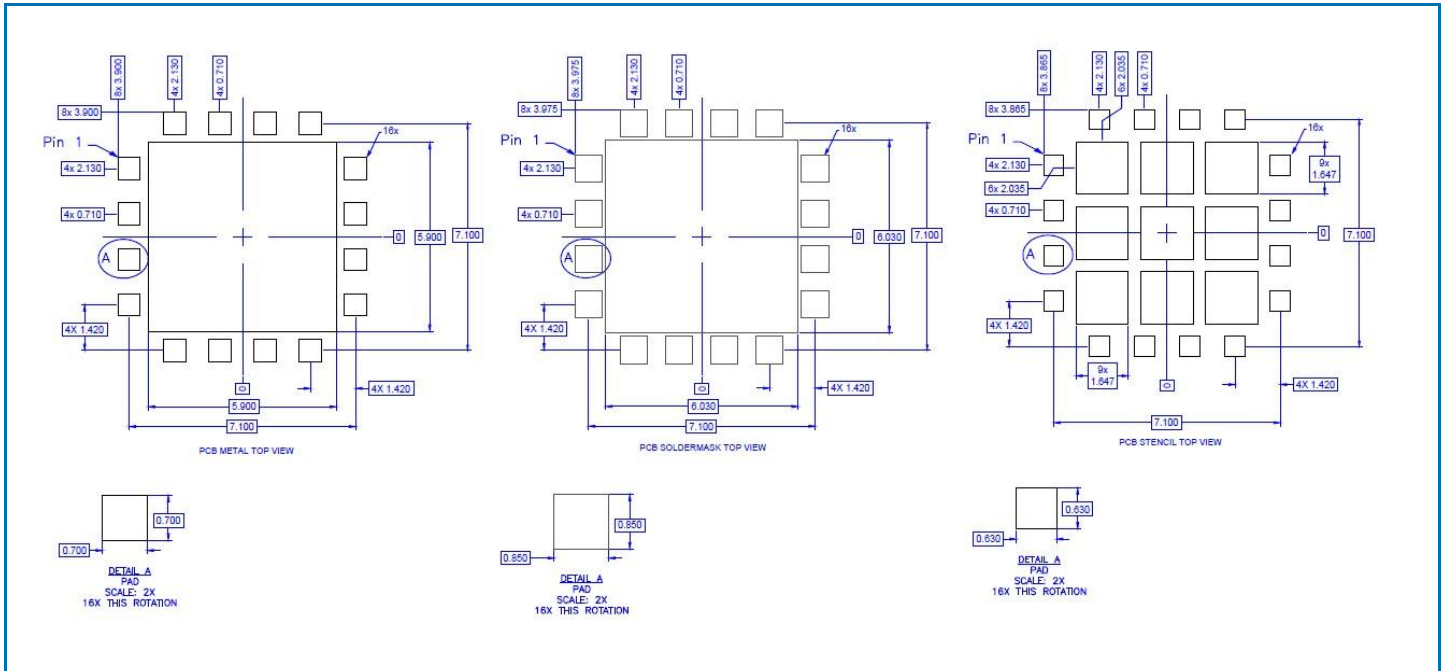

Branding Diagram

