

General Description

The RFPA2189 is a single-stage GaAs HBT power amplifier specifically designed for Wireless Infrastructure applications. It offers ultra-linear operation at a comparably low DC power making it ideal for next generation radios requiring high efficiency. Its external matching allows for use across various radio platforms within 400MHz to 2700MHz. The RFPA2189 offers low noise figure making it an excellent solution for 2nd and 3rd stage LNAs.



3 Pin SOT-89 Package

Functional Block Diagram

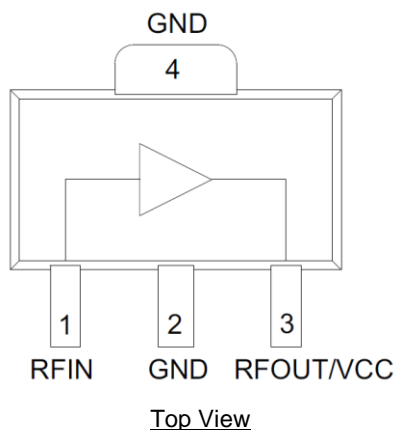

Product Features

- -60dBc ACPR at 16dBm WCDMA
- 0.5W Output Power (P1dB)
- Excellent Linearity to DC Power Ratio
- NF=3.0dB at 880MHz
- Single-Supply 5V Operation
- Class 1C (1000V) HBM ESD

Applications

- GaAs Pre-Driver for Base Station Amplifiers
- PA Stage for Commercial Wireless Infrastructure
- 2nd or 3rd Stage LNAs
- Class AB Operation for GSM, DCS, PCS, UMTS, WiMAX, LTE Transceiver Applications

Ordering Information

Part No.	Description
RFPA2189SR	7" Reel with 100 pieces
RFPA2189SQ	Sample bag with 25 pieces
RFPA2189TR7	7" Reel with 2500 pieces
RFPA2189PCK-410	869MHz to 894MHz PCBA with 5-piece sample bag
RFPA2189PCK-411	2110MHz to 2170MHz PCBA with 5-piece sample bag

Absolute Maximum Ratings

Parameter	Rating
Supply Voltage (V _{CC})	6 V
DC Supply Current (I _C)	380 mA
CW Input Power, 50 Ω output	+20 dBm
Output Load VSWR at P3dB	5:1
Operating Junction Temperature	160 °C
Storage Temperature	-55 to 150 °C

Notes:

- The maximum ratings must all be met simultaneously.
- $P_{DISS} = P_{DC} + P_{RFIN} - P_{RFOUT}$
- $T_J = T_L + P_{DISS} \cdot R_{TH}$
- Exceeding any one or a combination of the Absolute Maximum Rating conditions may cause permanent damage to the device. Extended application of Absolute Maximum Rating conditions to the device may reduce device reliability.

Recommended Operating Conditions

Parameter	Min	Typ	Max	Units
Operating Temperature Range (T _L)	-40		+105	°C

Electrical specifications are measured at specified test conditions. Specifications are not guaranteed over all recommended operating conditions.

Electrical Specifications

Parameter	Conditions	Min	Typ	Max	Units
869MHz to 894MHz					
Frequency	V _{CC} = 5.0V, I _{CQ} = 155mA EVB tuned for optimum ACPR	869	880	894	MHz
Input Power (P _{in})	Max recommended continuous input power, V _{CC} < 5.25V, Load VSWR < 2:1			+13	dBm
Gain (S ₂₁)			19.5		dB
OIP ₃	15 dBm/tone, tone spacing = 1 MHz		+43		dBm
P1dB	EVB tuned for linear operation		+27.5		dBm
Input Return Loss (S ₁₁)			13		dB
Output Return Loss (S ₂₂)			13		dB
Noise Figure			2.8		dB
WCDMA Channel Power at -55dBc ACPR	3GPP 3.5, Test Model 1, 64 DPCH		+17		dBm
UMTS 2100MHz					
Frequency	V _{CC} = 5.0V, I _{CQ} = 155mA EVB tuned for optimum ACPR	2110	2140	2170	MHz
Input Power (P _{in})	Max recommended continuous input power, V _{CC} < 5.25V, Load VSWR < 2:1			+18	dBm
Gain (S ₂₁)			14.5		dB
OIP ₃	15 dBm/tone, tone spacing = 1 MHz		+42.5		dBm
P1dB	EVB tuned for linear operation		+27		dBm
Input Return Loss (S ₁₁)			13		dB
Output Return Loss (S ₂₂)			13		dB
Noise Figure			2.8		dB
WCDMA Channel Power at -55dBc ACPR	3GPP 3.5, Test Model 1, 64 DPCH		+16.8		dBm
Power Supply					
Operating Current (Quiescent)	At V _{CC} = 5.0V		155		mA
Operating Voltage (V _{CC})	Max recommended collector voltage for continuous operation		5.0	5.25	V
Thermal Resistance (R _{TH})	At V _{CC} = 5.0V		58		°C/W

Typical Performance – 869MHz to 894MHz Application Circuit

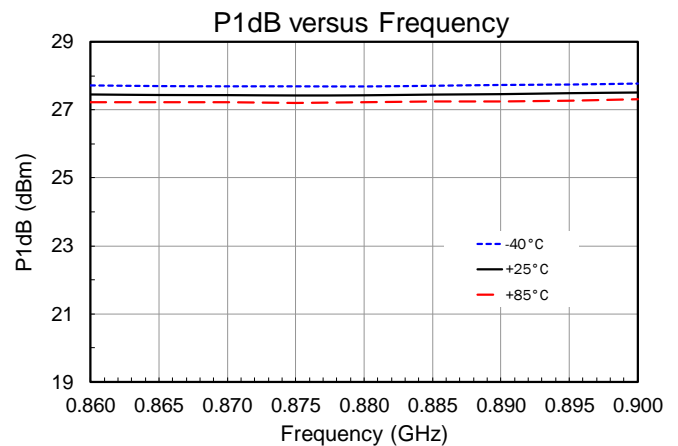
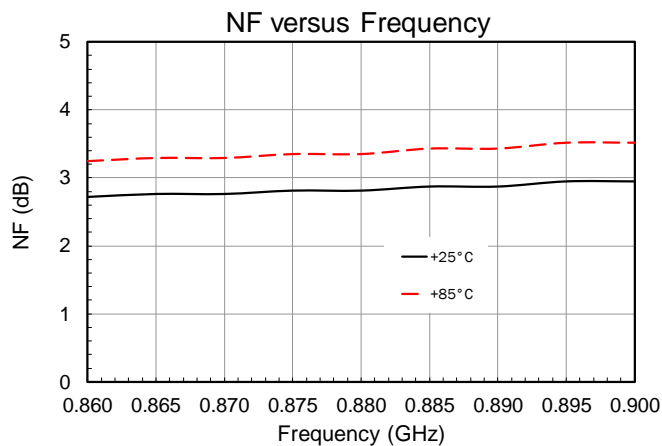
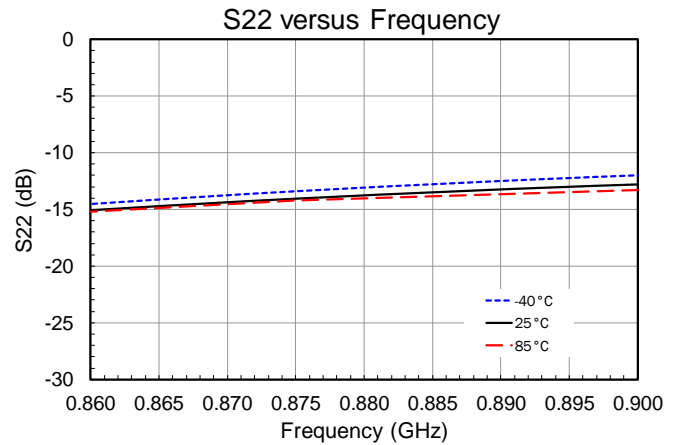
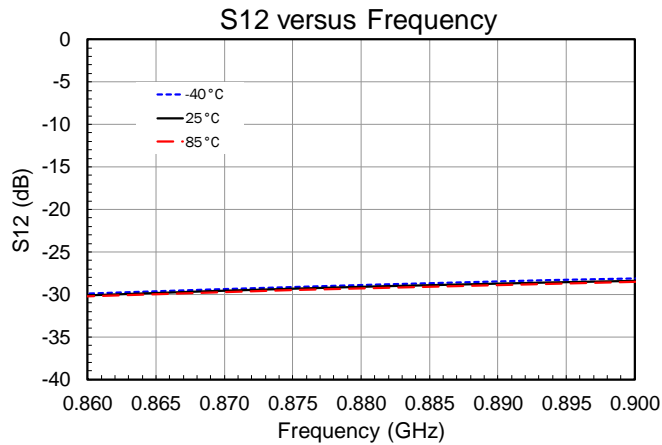
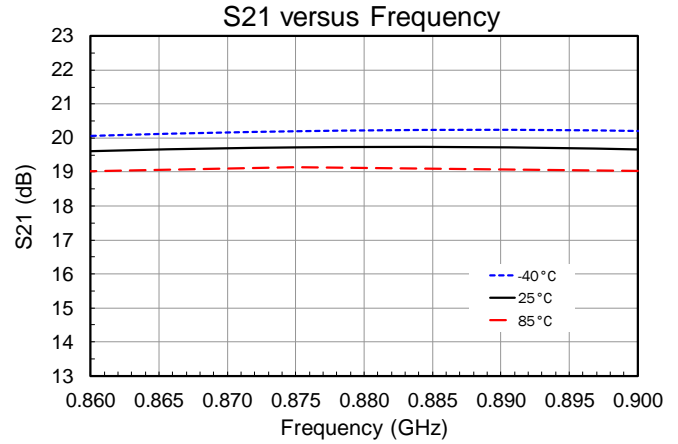
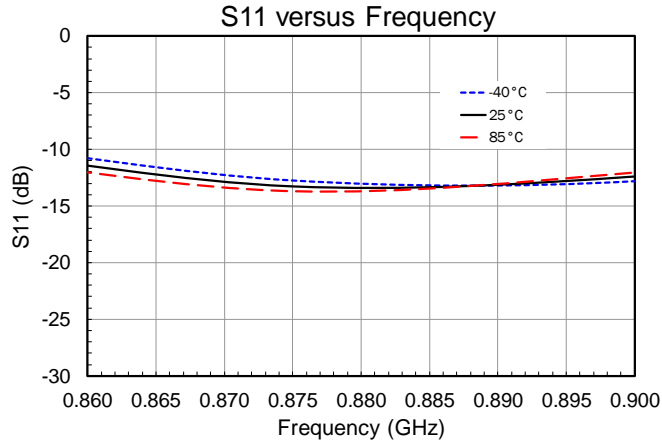

Typical Performance – 869MHz to 894MHz Application Circuit

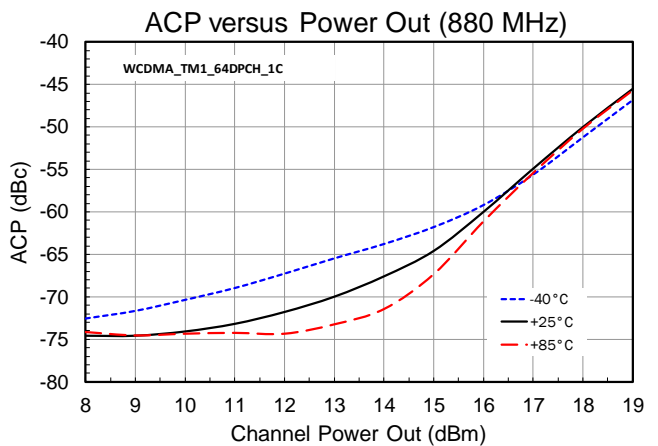
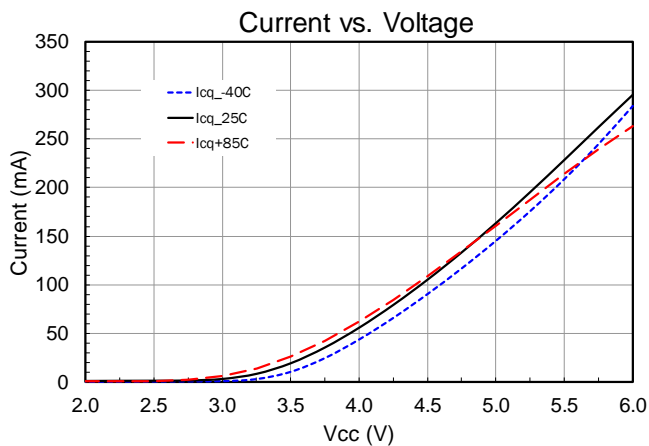
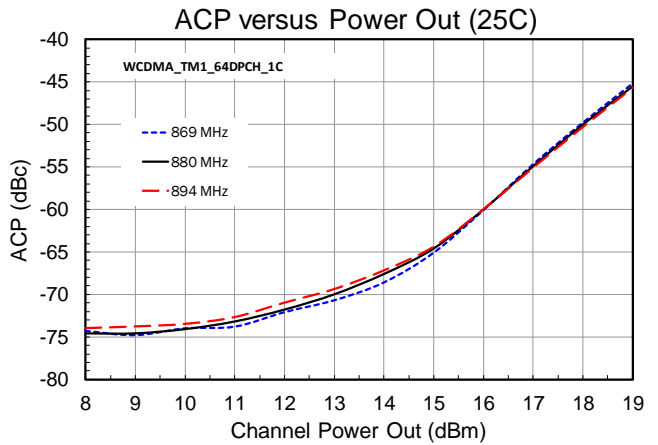
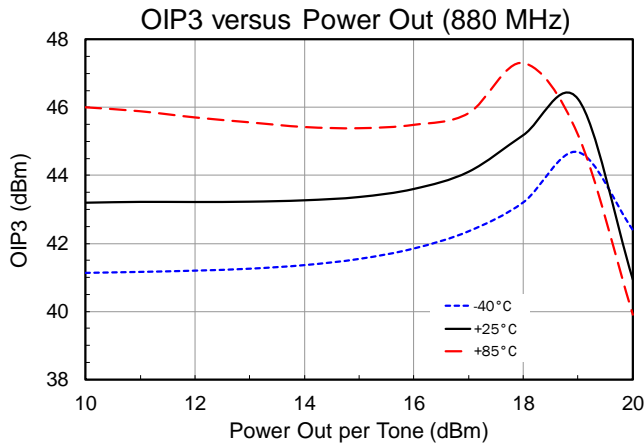
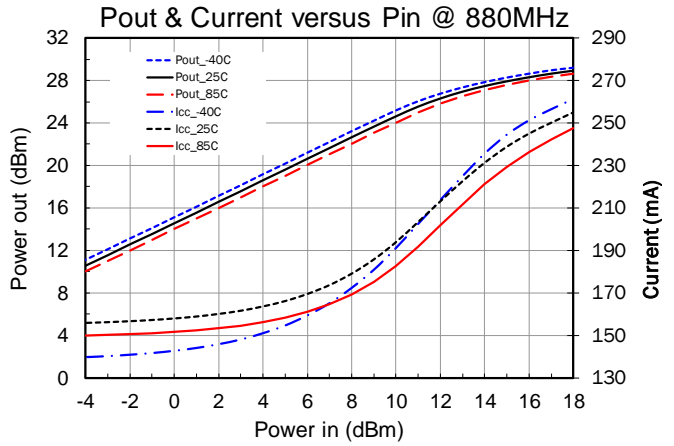
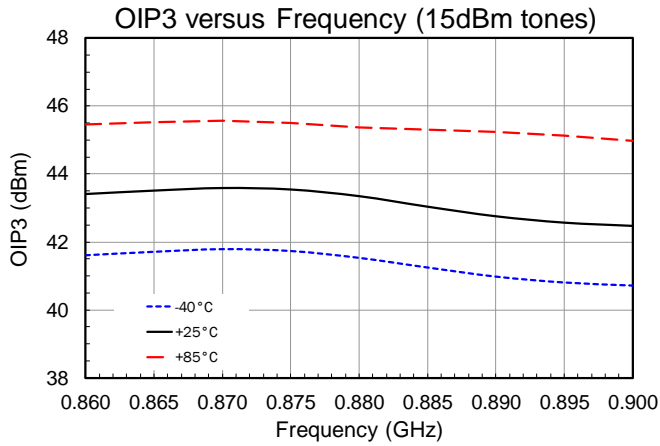

Evaluation Board Schematic – 869MHz to 894MHz Application Circuit

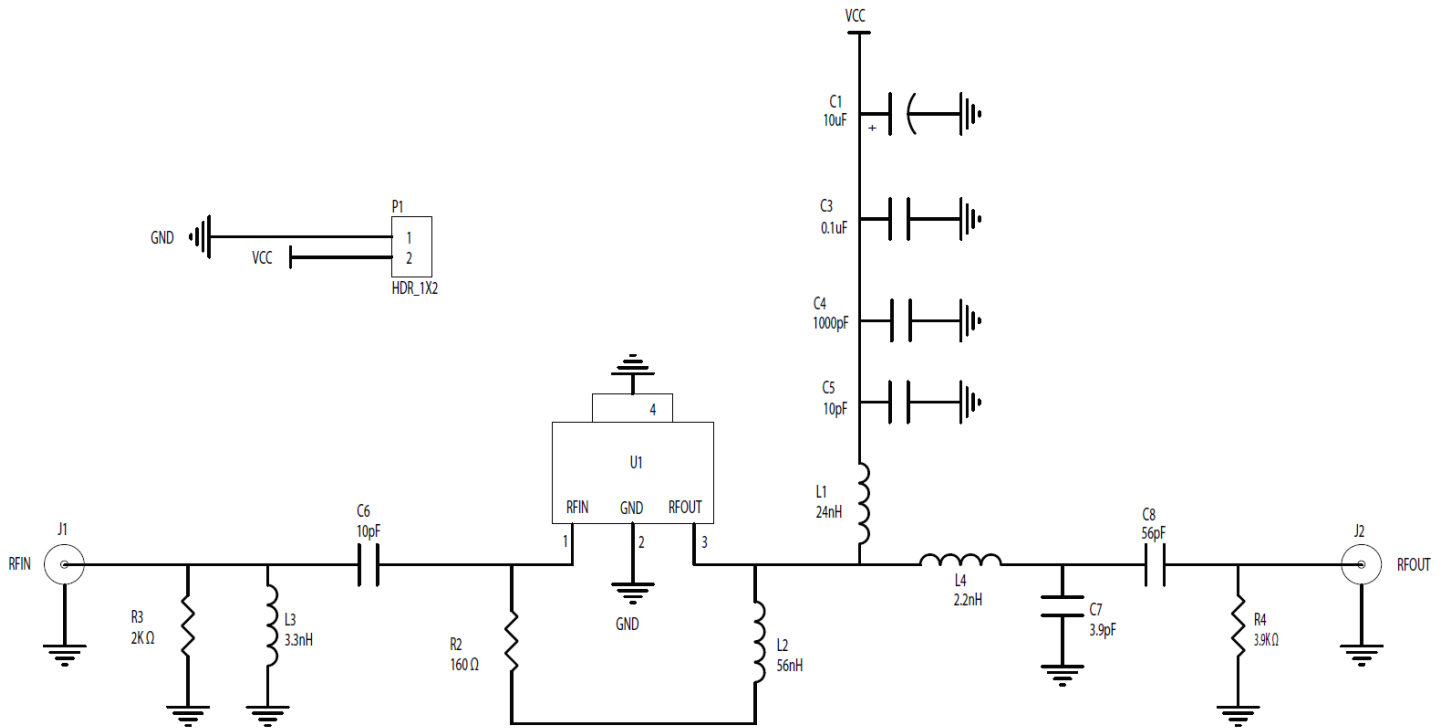

Evaluation Board Bill of Materials (BOM) – 869MHz to 894MHz Application Circuit

Reference	Value	Description	Manuf.	Part Number
		PCB PA2189410(A)		PA2189410(A)
U1		GaAs HBT Power Amplifier	Qorvo	RFPA2189
C1	10uF	CAP, 20%, 10V, TANT-A	Kemet	T491A106M010AT
C4	1000pF	CAP, 10%, 50V, X7R, 0603	Panasonic	ECJ-1VB1H102K
C3	0.1uF	CAP, 10%, 16V, X7R, 0603	Murata Electronics	GRM188R71C104KA01D
C5	10pF	CAP, 5%, 50V, C0G, 0603	Johanson Technology	500R14N100JV4
C6	10pF	CAP, 5%, 50V, C0G, 0402	Murata Electronics	GRM1555C1H100JZ01E
C7	3.9pF	CAP, +/-0.25pF, 50V, C0G, 0402	Murata Electronics	GRM1555C1H3R9CZ01E
C8	56pF	CAP, 5%, 50V, C0G, 0402	Murata Electronics	GRM1555C1H560JZ01D
J1, J2		CONN, SMA, END LNCH, MINI, FLT, 0.068"	Emerson Networks	142-0741-851
L1	24nH	IND, 5%, W/W, 0603	Coilcraft, Inc.	0603HC-24NXJLW
L2	56nH	IND, 5%, M/L, 0402	TOKO	LL1005-FHL56NJ
L3	3.3nH	IND, +/- 0.3nH, M/L, 0603	TOKO	LL1608-FSL3N3S
L4	2.2nH	IND, +/-0.3nH, M/L, 0603	TOKO	LL1608-FSL2N2S
P1		CONN, HDR, ST, PLRZD, 2-PIN, 0.100"	ITW Pancon	MPSS100-2-C
R2	160 Ω	RES, 5%, 1/16W, 0402	Kamaya, Inc	RMC1/16S-161JTH
R3	2k Ω	RES, 5%, 1/16W, 0402	Panasonic	ERJ-2GEJ202
R4	3.9k Ω	RES, 5%, 1/16W, 0402	Panasonic	ERJ-2GEJ392
R1, C2, J3, J4		DNP		

Evaluation Board Assembly Drawing – 869MHz to 894MHz Application Circuit

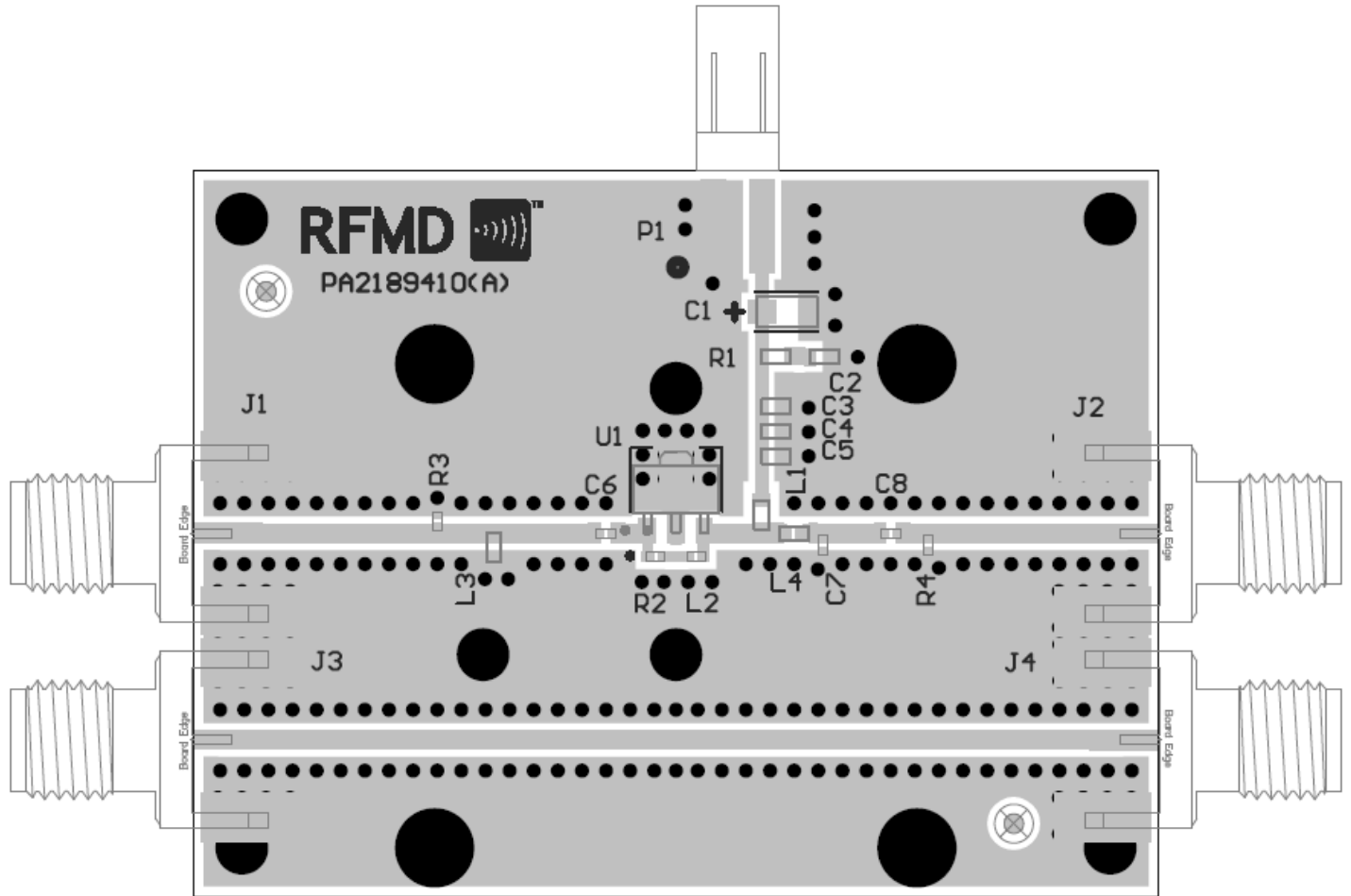

(Refer to Schematic and BOM for specific component requirements, some items in the EVB drawing are DNP)

Typical Performance – 2110MHz to 2170MHz Application Circuit

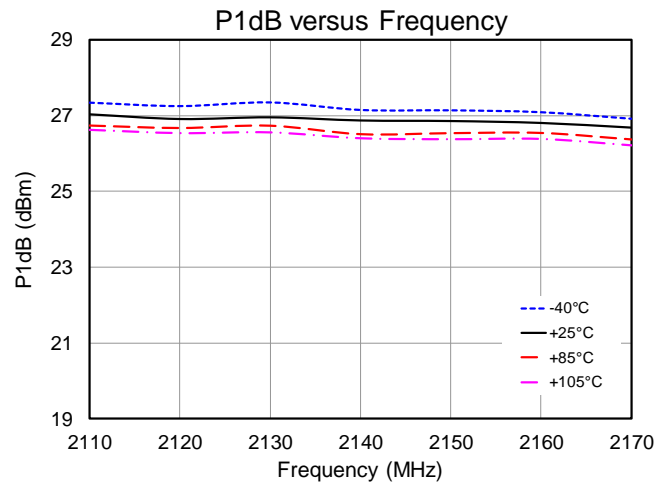
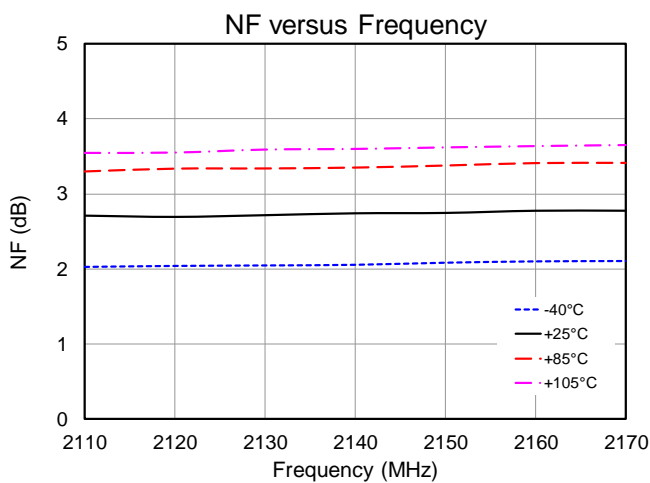
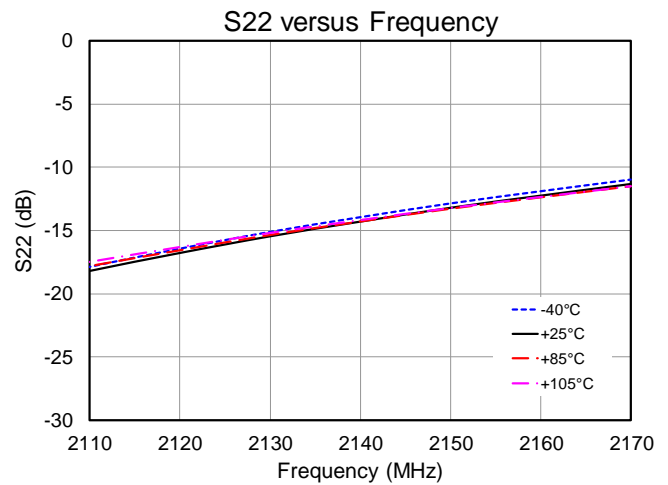
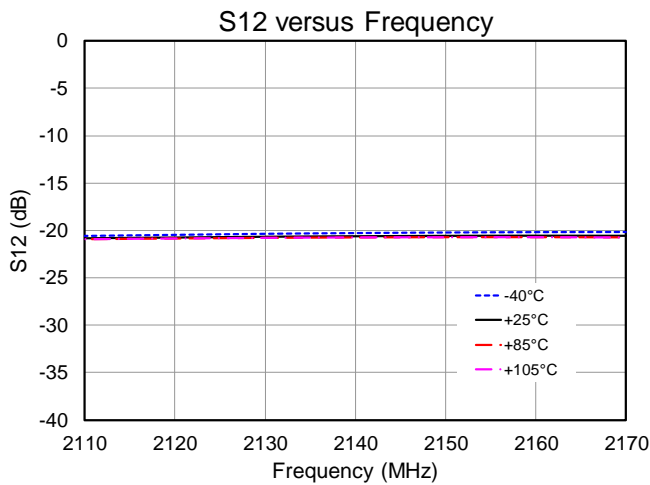
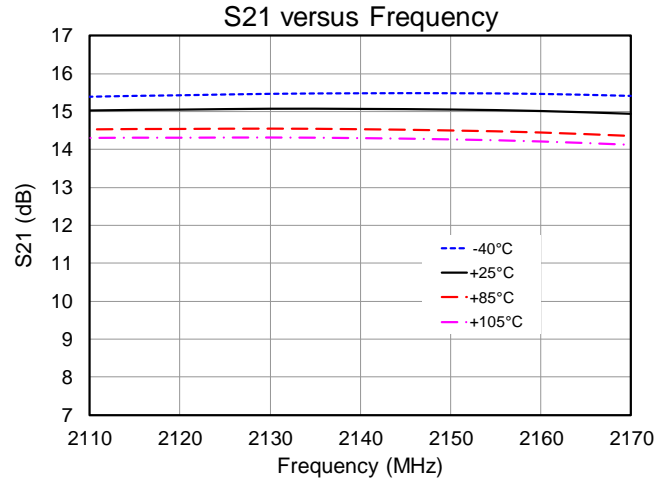
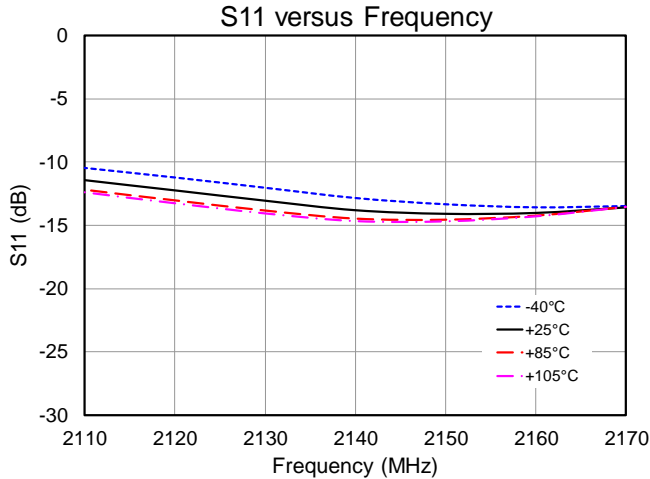

Typical Performance – 2110MHz to 2170MHz Application Circuit

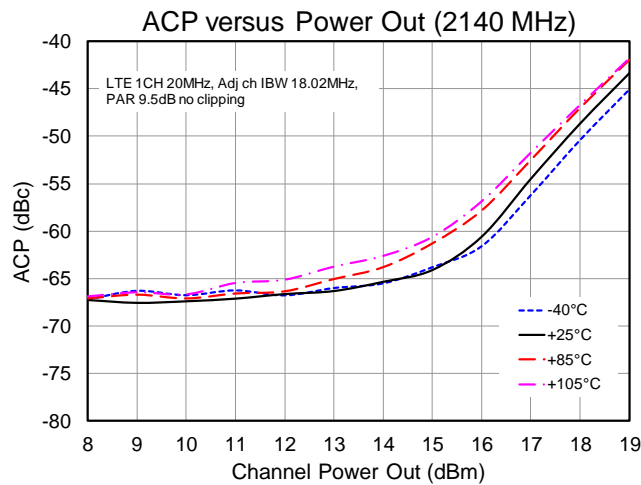
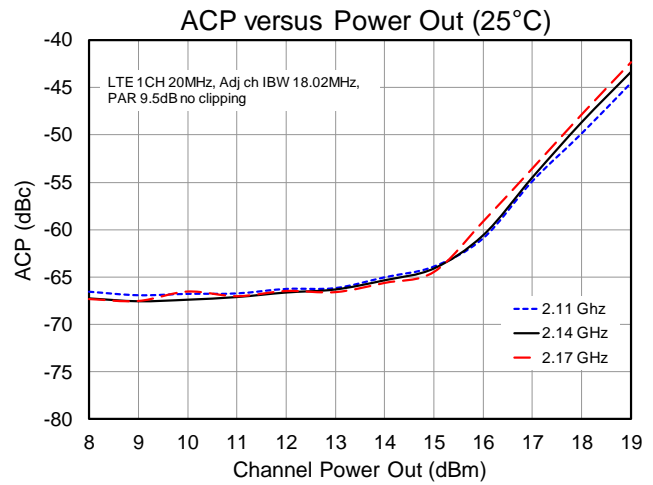
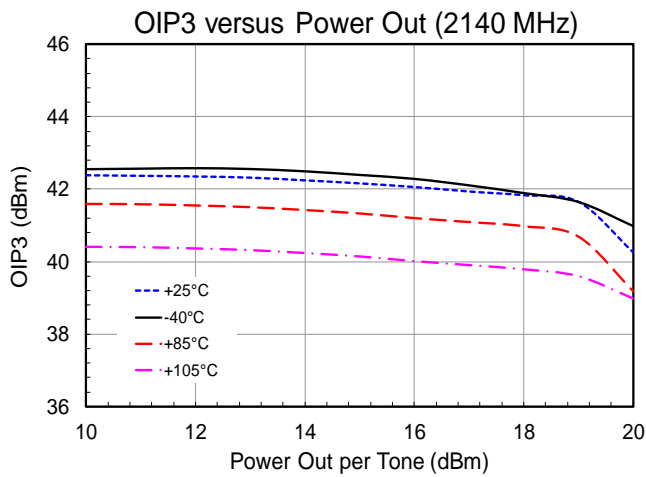
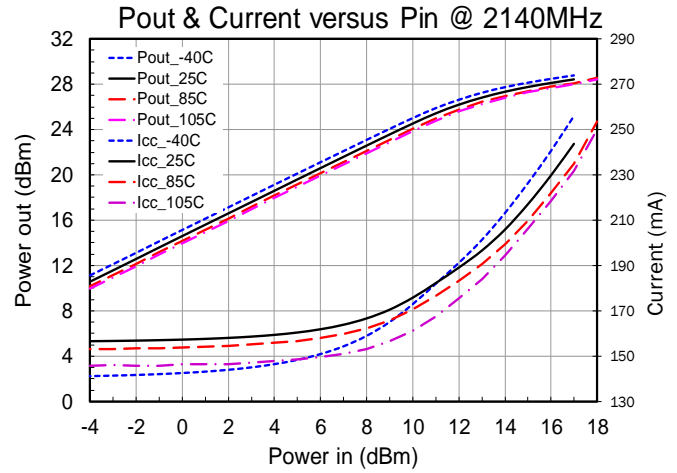
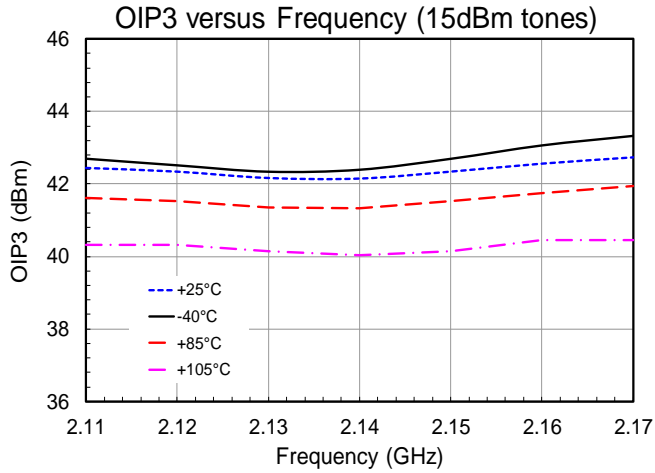

Evaluation Board Schematic – 2110MHz to 2170MHz Application Circuit

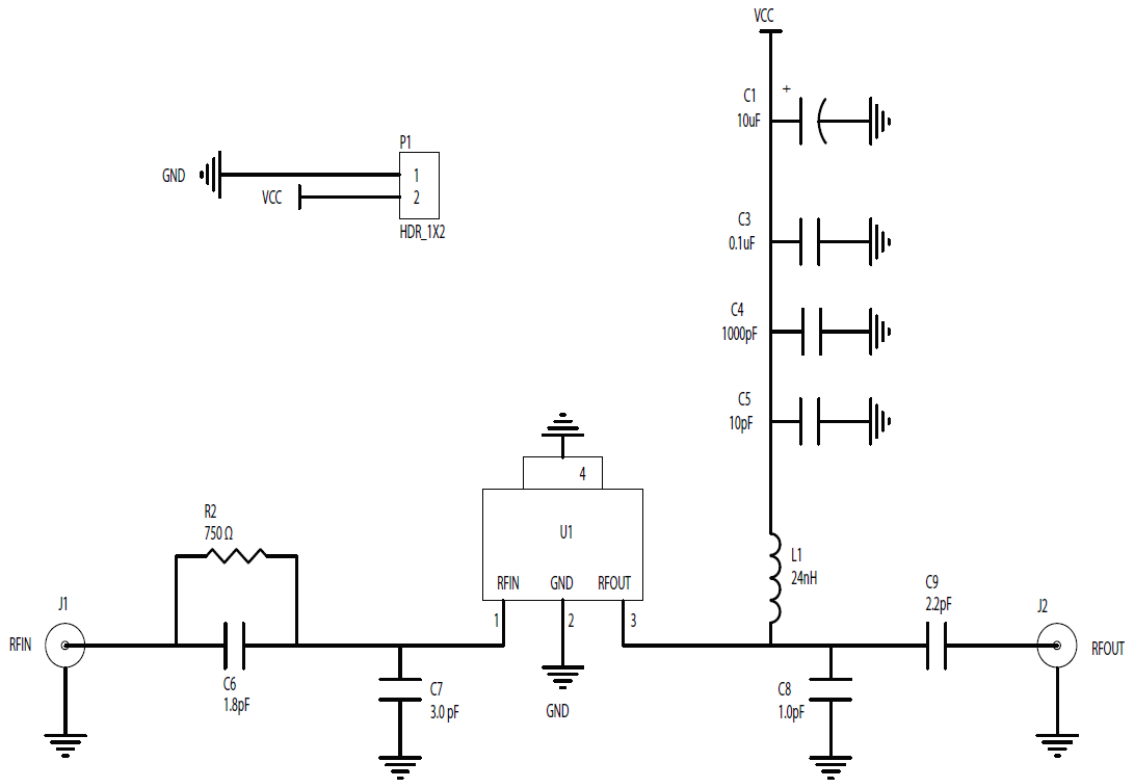

Evaluation Board Bill of Materials – 2110MHz to 2170MHz Application Circuit

Reference	Value	Description	Manuf.	Part Number
		PCB PA2189410(A)		PA2189411(A)
U1		GaAs HBT Power Amplifier	Qorvo	RFPA2189
C1	10uF	CAP, 20%, 10V, TANT-A	Kemet	T491A106M010AT
C4	1000pF	CAP, 10%, 50V, X7R, 0603	Panasonic	ECJ-1VB1H102K
C3	0.1uF	CAP, 10%, 16V, X7R, 0603	Murata Electronics	GRM188R71C104KA01D
C5	10pF	CAP, 5%, 50V, C0G, 0603	Johanson Technology	500R14N100JV4
C6	1.8pF	CAP, +/-0.1pF, 50V, C0G, 0402	Murata Electronics	GRM1555C1H1R8BZ01E
C7	3pF	CAP, +/-0.1pF, 50V, C0G, 0402	Murata Electronics	GRM1555C1H3R0BZ01E
C8	1pF	CAP, +/-0.1pF, 50V, HI-Q, 0402	Johanson Technology	500R07S1R0BV4TD
C9	2.2pF	CAP, +/-0.1pF, 50V, HI-Q, 0402	Johanson Technology	500R07S2R2BV4TD
J1, J2		CONN, SMA, END LNCH, MINI, FLT, 0.068"	Emerson Networks	142-0741-851
L1	24nH	IND, 5%, W/W, 0603	Coilcraft, Inc.	0603HC-24NXJLW
P1		CONN, HDR, ST, PLRZD, 2-PIN, 0.100"	ITW Pancon	MPSS100-2-C
R2	750 Ω	RES, 1%, 1/16W, 0402	Panasonic	ERJ-2RKF7500X
R1, C2, J3, J4		DNP		

Evaluation Board Assembly Drawing – 2110MHz to 2170MHz Application Circuit

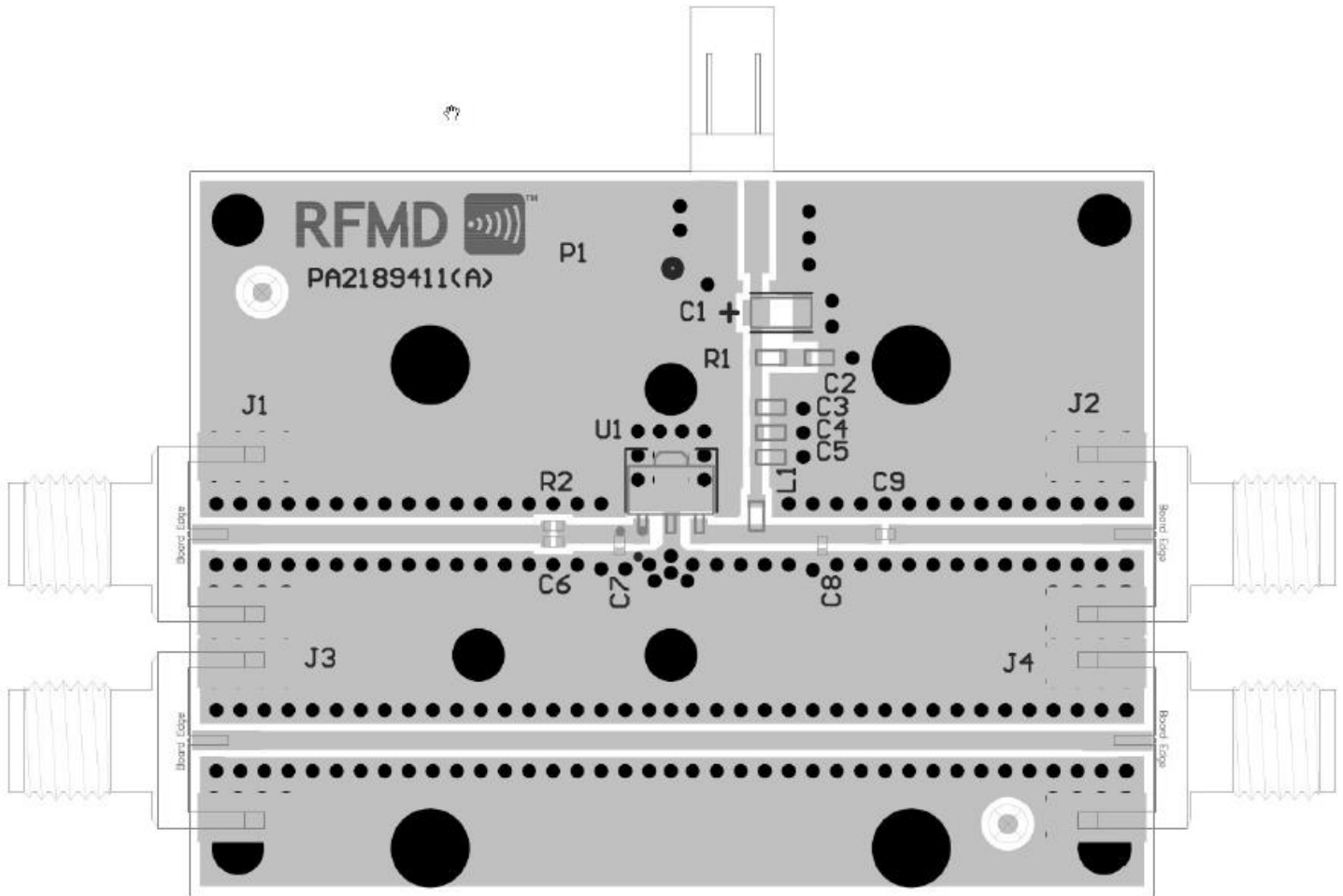

(Refer to Schematic and BOM for specific component requirements, some items in the EVB drawing are DNP)

Pin Names and Description

Pin No.	Label	Description
1	RF IN	RF Input. External DC Block is required.
2	GND	DC and RF Ground
3	RF OUT/V _{CC}	RF Output. Device Collector
4	GND	DC and RF Ground. Must be soldered to EVB ground plane over a bed of vias for thermal and RF performance.

Package Marking

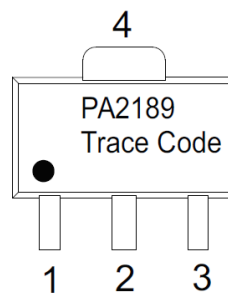

Trace Code to be assigned by the assembly SubCon.

PCB Mounting Pattern

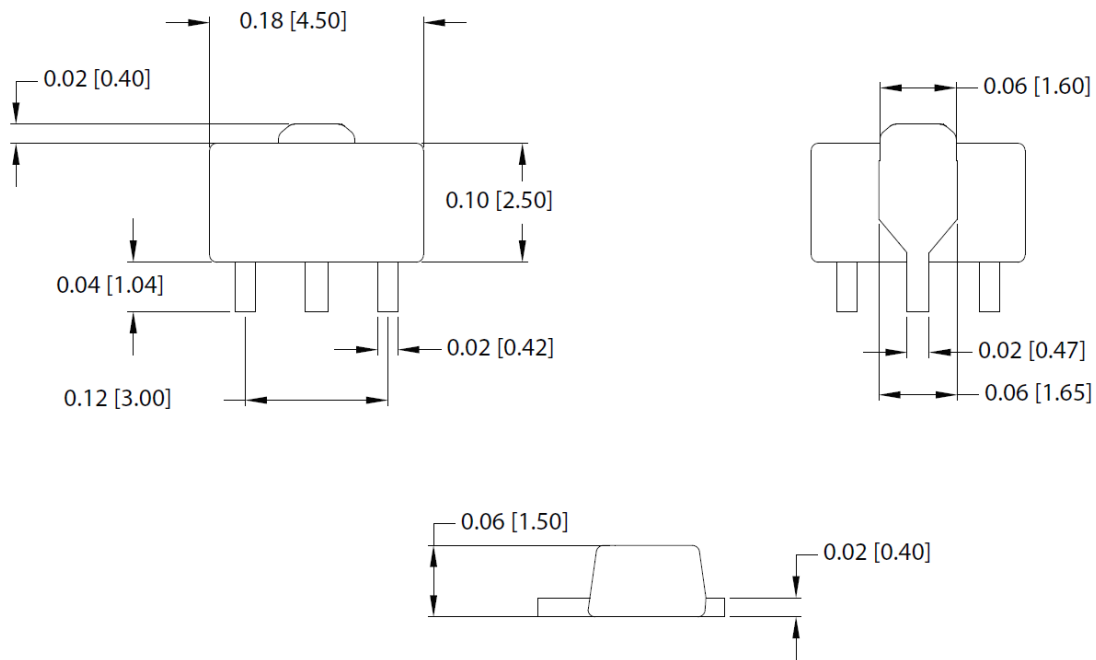

Notes:

1. All dimensions are in millimeters. Angles are in degrees.
2. Refer to drawing posted at www.rfmd.com for tolerances.

Handling Precautions

Parameter	Rating	Standard
ESD – Human Body Model (HBM)	Class 1C	ESDA / JEDEC JS-001-2014
MSL – Moisture Sensitivity Level	Level 2	IPC/JEDEC J-STD-020



Caution!
ESD-Sensitive Device

Solderability

Compatible with lead-free (260°C max. reflow temp.) soldering process.
 Solder profiles available upon request.

Contact plating: NiPdAu

RoHS Compliance

This part is compliant with 2011/65/EU RoHS directive (Restrictions on the Use of Certain Hazardous Substances in Electrical and Electronic Equipment) as amended by Directive 2015/863/EU.

This product also has the following attributes:

- Lead Free
- Halogen Free (Chlorine, Bromine)
- Antimony Free
- TBBP-A (C₁₅H₁₂Br₄O₂) Free
- PFOS Free
- SVHC Free



Contact Information

For the latest specifications, additional product information, worldwide sales and distribution locations:

Web: www.qorvo.com

Tel: 1-844-890-8163

Email: customer.support@qorvo.com

For technical questions and application information: **Email:** appsupport@qorvo.com

Important Notice

The information contained herein is believed to be reliable; however, Qorvo makes no warranties regarding the information contained herein and assumes no responsibility or liability whatsoever for the use of the information contained herein. All information contained herein is subject to change without notice. Customers should obtain and verify the latest relevant information before placing orders for Qorvo products. The information contained herein or any use of such information does not grant, explicitly or implicitly, to any party any patent rights, licenses, or any other intellectual property rights, whether with regard to such information itself or anything described by such information. **THIS INFORMATION DOES NOT CONSTITUTE A WARRANTY WITH RESPECT TO THE PRODUCTS DESCRIBED HEREIN, AND QORVO HEREBY DISCLAIMS ANY AND ALL WARRANTIES WITH RESPECT TO SUCH PRODUCTS WHETHER EXPRESS OR IMPLIED BY LAW, COURSE OF DEALING, COURSE OF PERFORMANCE, USAGE OF TRADE OR OTHERWISE, INCLUDING THE IMPLIED WARRANTIES OF MERCHANTABILITY AND FITNESS FOR A PARTICULAR PURPOSE.**

Without limiting the generality of the foregoing, Qorvo products are not warranted or authorized for use as critical components in medical, life-saving, or life-sustaining applications, or other applications where a failure would reasonably be expected to cause severe personal injury or death.

Copyright 2017 © Qorvo, Inc. | Qorvo is a registered trademark of Qorvo, Inc.