

# RFPA5512

## WiFi Integrated PA Module 4.9GHz to 5.85GHz

The RFPA5512 is a three-stage power amplifier (PA) designed for 802.11a/n/ac applications. The integrated input and output 50Ω match greatly reduces the layout area, bill of materials and manufacturability cost in the customer application. The RFPA5512 is manufactured on an advanced InGaP heterojunction bipolar transistor (HBT) process and is capable of achieving linear powers up to 23dBm with an EVM <1.8% while maintaining excellent power added efficiency. The device is provided in a 4.0mm x 4.0mm x 0.9mm QFN package that meets or exceeds the power requirements of IEEE802.11a/n/ac WiFi RF systems.

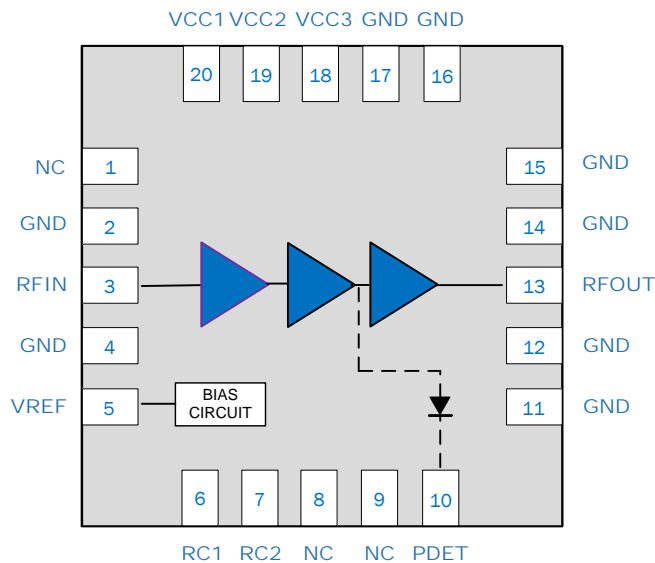

Functional Block Diagram

### Ordering Information

RFPA5512SB	Standard 5-piece Sample Bag
RFPA5512SQ	Standard 25-piece Sample Bag
RFPA5512SR	Standard 100-piece Reel
RFPA5512TR13	Standard 2500-piece Reel
RFPA5512PCK-410	Fully Assembled Eval Board w/5-piece bag



Package: QFN, 20-pin,  
4.0mm x 4.0mm x 0.9mm

### Features

- $P_{OUT} = 23\text{dBm}$ , 5V, 11ac, 80MHz MCS9 @ 1.8% EVM
- $P_{out} = 25\text{dBm}$ , 5V, 11n, 20/40 MHz, MCS7 @ 3%
- Typical Gain = 33dB
- High PAE
- Input and Output Matched to 50Ω
- Integrated Power Detector, Harmonic filter, and notch filter

### Applications

- Customer Premise Equipment (CPE)
- Wireless Access Points, Gateways
- Routers
- Set-Top Box Applications
- Picocell/Femtocell

## Absolute Maximum Ratings

Parameter	Rating	Unit
DC Supply Voltage	-0.5 to +6	V <sub>DC</sub>
DC Supply Current	1000	mA
Operating Temperature Range	-40 to +85	°C
Storage Temperature	-40 to +150	°C
Maximum TX Input Power into 50Ω for 11a/n/ac (No Damage). *R1=0Ω	+10	dBm
Maximum TX Input Power 10:1 VSWR for 11a/n/ac (No Damage). *R1=15Ω	+15	dBm
Moisture Sensitivity Level (260°C JEDEC J-STD-020)	MSL2	

\*Note: For R1 placement please refer to the applications schematic



Caution! ESD sensitive device.



RFMD Green: RoHS status based on EU Directive 2011/65/EU (at time of this document revision), halogen free per IEC 61249-2-21, < 1000ppm each of antimony trioxide in polymeric materials and red phosphorus as a flame retardant, and <2% antimony in solder.

Exceeding any one or a combination of the Absolute Maximum Rating conditions may cause permanent damage to the device. Extended application of Absolute Maximum Rating conditions to the device may reduce device reliability. Specified typical performance or functional operation of the device under Absolute Maximum Rating conditions is not implied. This is an InGaP PA designed for high duty cycle applications with T<sub>j</sub>>100°C.

## Nominal Operating Parameters

Parameter	Specification			Unit	Condition
	Min	Typ	Max		
<b>Compliance</b>					<b>IEEE802.11a/n/ac</b>
Operating Frequency	5.180		5.925	GHz	
Extended Operating Frequency	4.900		5.180	GHz	
Power Supply V <sub>CC</sub>	4.75	5.00	5.25	V	
Power Supply V <sub>REF</sub>	2.85	2.90	2.95	V	
					<b>T= +25°C, V<sub>CC</sub>=5.0V, V<sub>REF</sub> = 2.90V, Over Operating Frequency Range, Unless Otherwise Noted</b>
IEEE802.11ac 80MHz Output Power	22	23		dBm	MCS9, 256QAM
IEEE802.11ac 80MHz EVM		1.5	1.8	%	
IEEE802.11ac 80MHz EVM		-36.5	-35	dB	
IEEE802.11n 20/40MHz Output Power	23.5	25		dBm	MCS7, 64QAM
IEEE802.11n 40MHz EVM		2.5	3	%	
IEEE802.11n 40MHz EVM		-32.0	-30.5	dB	
Large Signal Gain	31	33		dB	
Gain Variation over Temp	-2.0		+2.0	dB	Over Any 100MHz Frequency band
Margin to Spectral Mask		5	0	dB	P <sub>OUT</sub> =25dBm; MCS0 80MHz
		5	0	dB	P <sub>OUT</sub> =26dBm; MCS0 40MHz
		5	0	dB	P <sub>OUT</sub> =27dBm; MCS0 20MHz, 11a 6Mbps
Operating Current		275	325	mA	P <sub>OUT</sub> =23dBm
		375	420	mA	P <sub>OUT</sub> =27dBm
Quiescent Current		140		mA	
V <sub>REF</sub> Current		12		mA	
Leakage Current		100	250	nA	RF OFF; V <sub>REF</sub> = 0V
Second Harmonic		-45	-40	dBm/MHz	P <sub>OUT</sub> = 27dB Over Operating Frequency band.
Third Harmonic		-50	-45	dBm/MHz	
OOB Rejection		-5		dB	Gain (S21)@ 3.3 – 3.8GHz
		7		dB	Gain ( S21)@ 7.0 GHz

Parameter	Specification			Unit	Condition
	Min	Typ	Max		
					<b>T= +25°C, V<sub>CC</sub>=5.0V, V<sub>REF</sub> = 2.90V, Over Operating Frequency Range, Unless Otherwise Noted</b>
Input Return Loss		15		dB	
Output Return Loss		12		dB	
Power Detector Range		0.25		V	P <sub>OUT</sub> = 0dBm, RF=OFF
		0.65		V	P <sub>OUT</sub> = 23dBm
		0.88		V	P <sub>OUT</sub> = 27dBm
<b>General Specifications</b>					
PA Stability Output Power Range in to 4:1 VSWR			27	dBm	CW signal. No spurious above -41.25dBm/MHz for non-harmonic related signals.
Output P1dB		33		dBm	CW signal
Ramp ON/OFF time		200		nS	10-90% / 90-10% of gain
Thermal Resistance*		35		°C/W	100% Duty Cycle, P <sub>OUT</sub> = 27dBm
ESD HBM	500			V	EIA/JESD22-114A; All pins
ESD CDM	300			V	JESD22-C101C; All pins

Timing Diagram

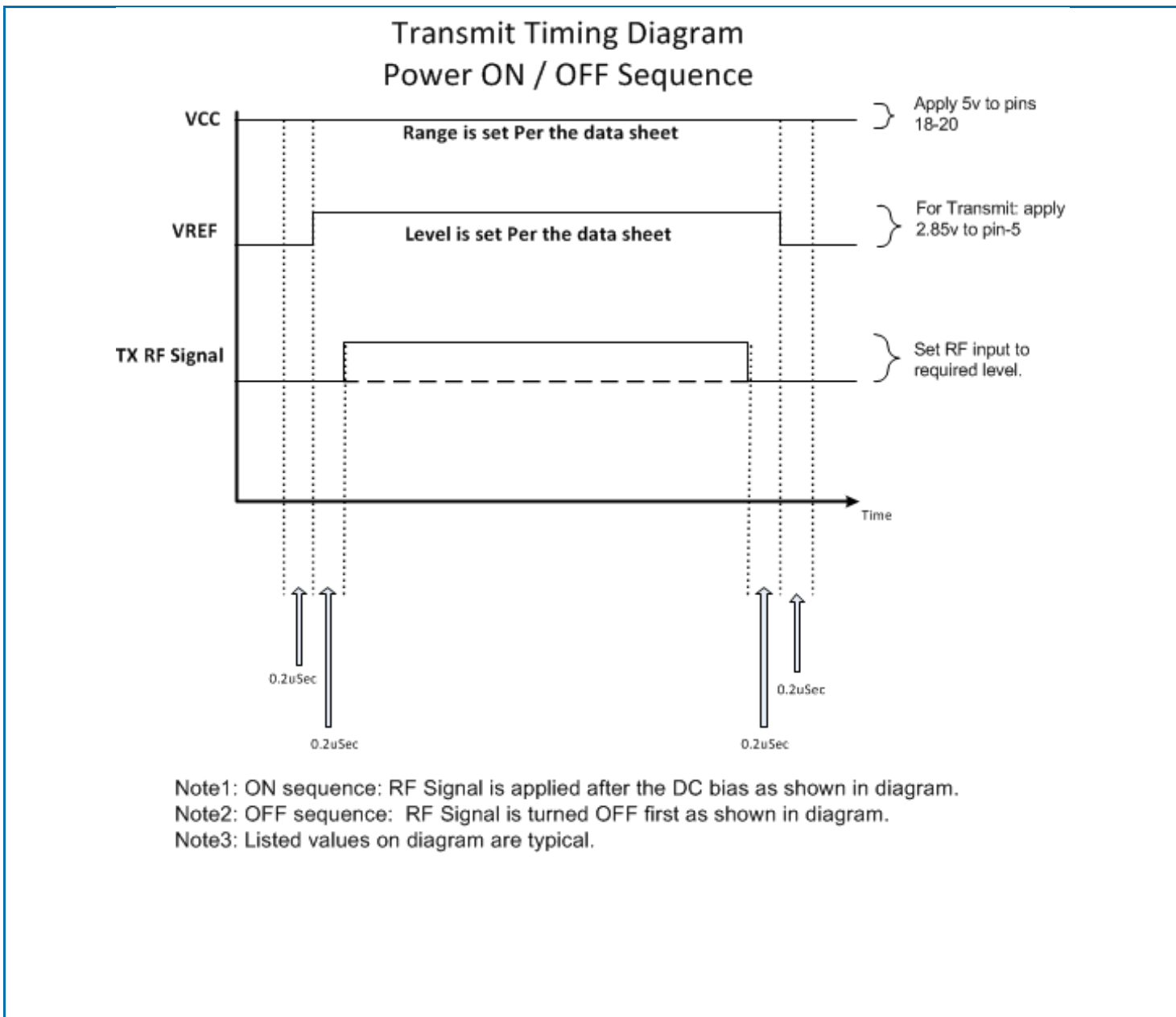

Evaluation Board Schematic

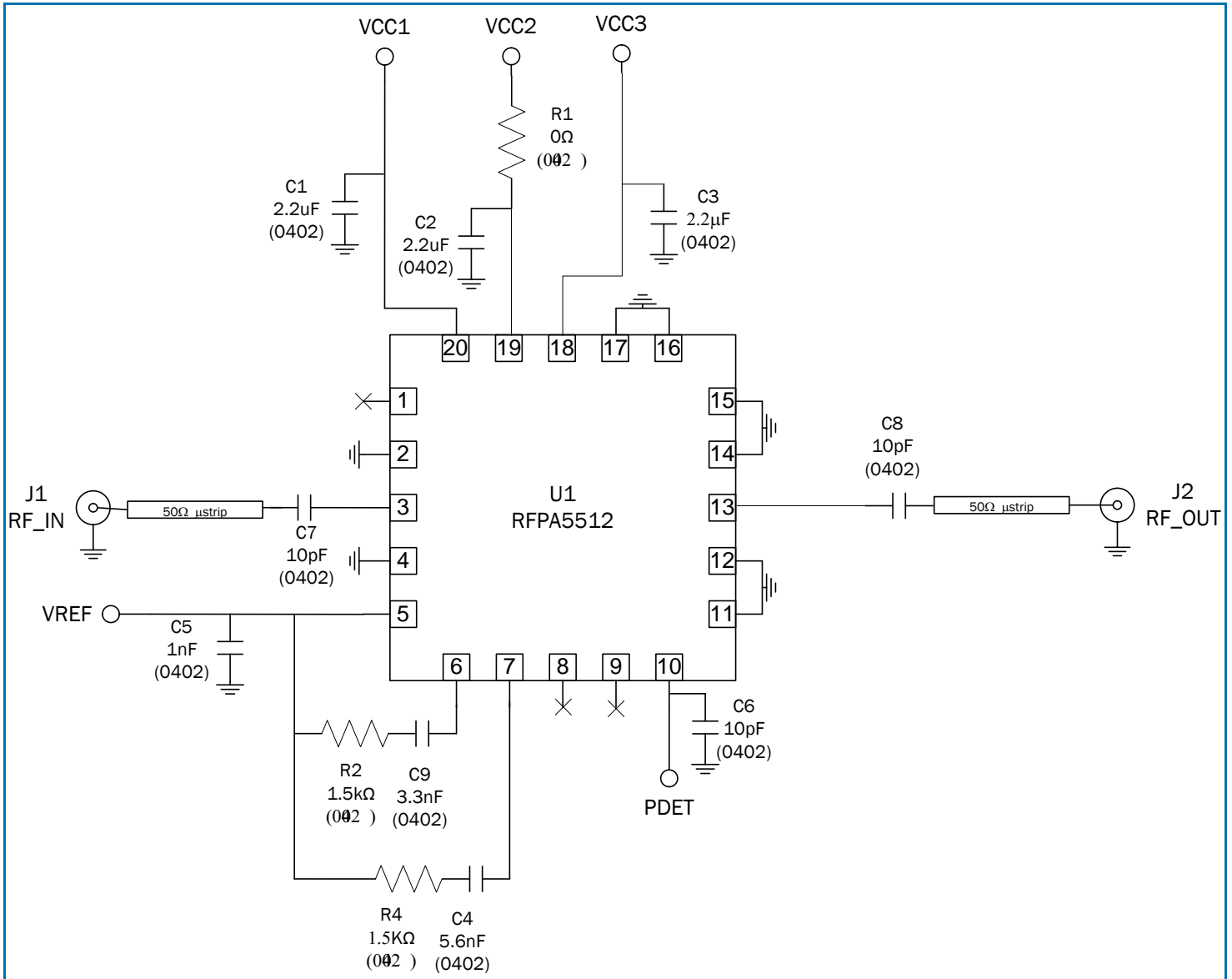

### Pin Out

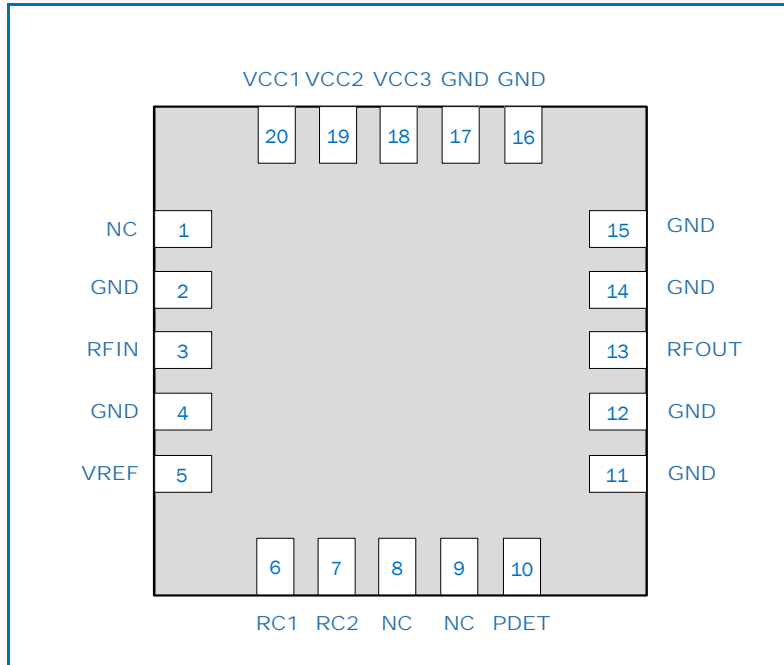

### Package Drawing (dimensions in mm)

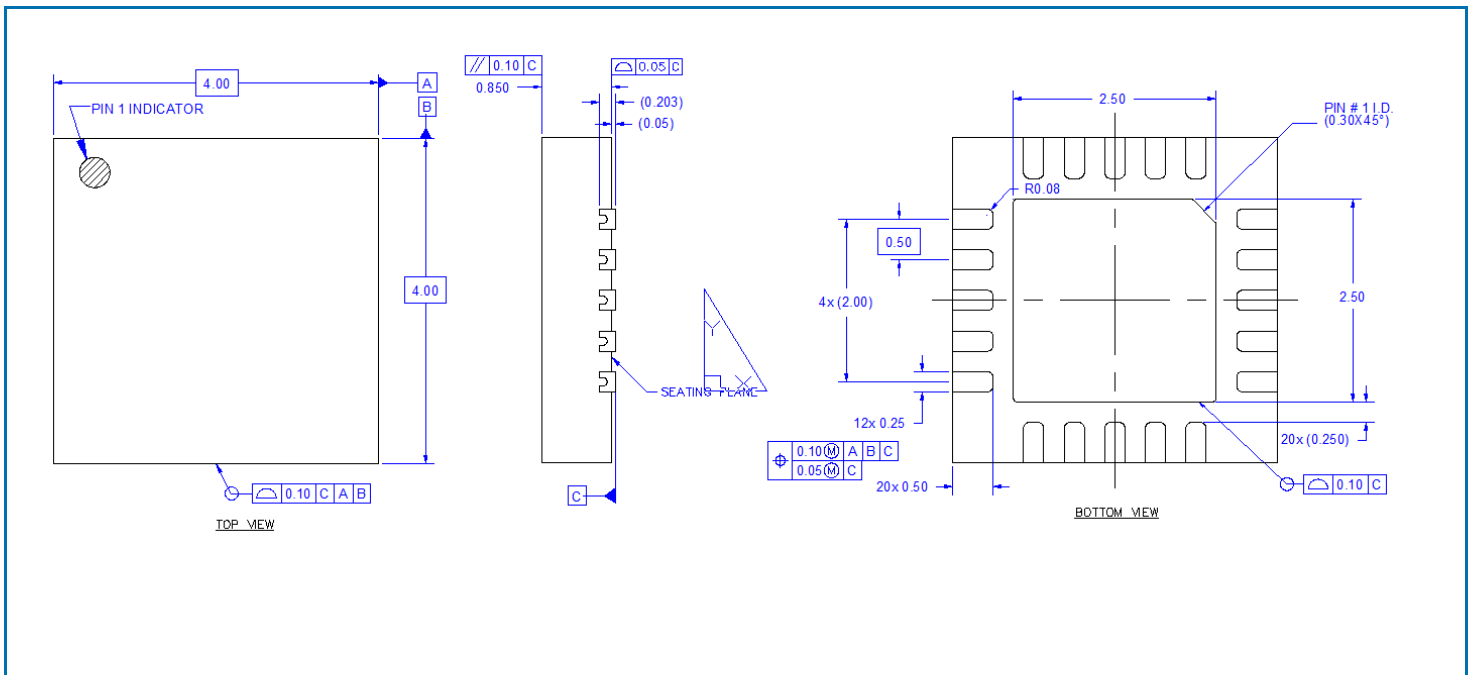

PCB Patterns (dimensions in mm)

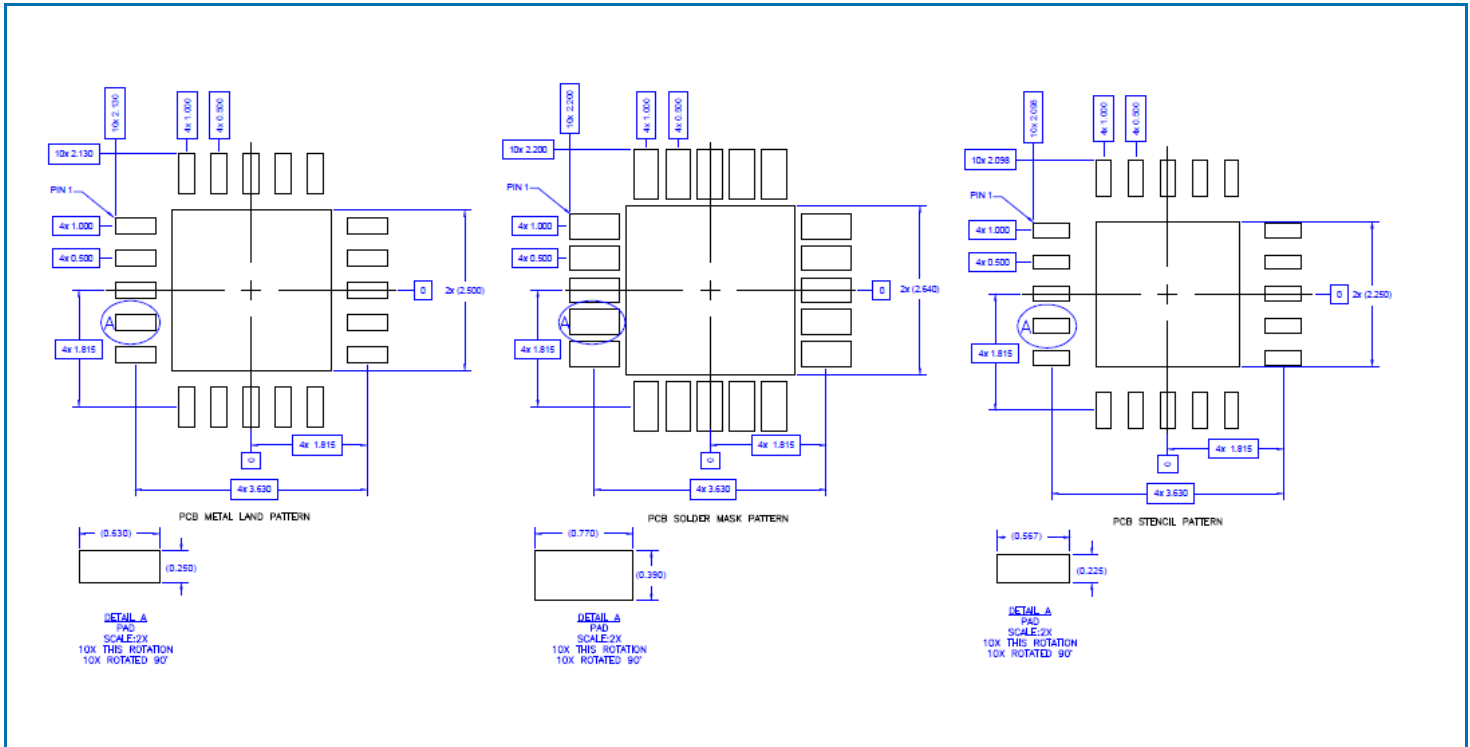

## Pin Names and Descriptions

Pin	Name	Description
1	NC	Not connected internally. It may be left floating or connected to ground.
2	GND	Ground connection. This pin is not connected internally and can be left floating or connected to ground.
3	RFIN	RF input, internally matched to 50Ω and DC shorted. External DC blocking capacitor required.
4	GND	Ground connection. This pin is not connected internally and can be left floating or connected to ground.
5	VREF	Input bias voltage. This pin requires a regulated supply to maintain nominal bias current.
6	RC1	Tuning RC pin 1. See EVB schematic for details.
7	RC2	Tuning RC pin 2. See EVB schematic for details.
8	NC	Not connected internally. It may be left floating or connected to ground.
9	NC	Not connected internally. It may be left floating or connected to ground.
10	PDET	Power detector. Provides an output voltage proportional to the RF output power level.
11	GND	Ground connection. This pin is not connected internally and can be left floating or connected to ground.
12	GND	Ground connection. This pin is not connected internally and can be left floating or connected to ground.
13	RFOUT	RF output, internally matched to 50Ω and DC shorted. External DC blocking capacitor required.
14	GND	Ground connection. This pin is not connected internally and can be left floating or connected to ground.
15	GND	Ground connection. This pin is not connected internally and can be left floating or connected to ground.
16	GND	Ground connection. This pin is not connected internally and can be left floating or connected to ground.
17	GND	Ground connection. This pin is not connected internally and can be left floating or connected to ground.
18	VCC3	Third stage supply voltage
19	VCC2	Second stage supply voltage.
20	VCC1	First stage supply voltage.
Pkg Base	GND	Ground connection. The back side of the package should be connected to the ground plan though as short of a connection as possible. PCB vias under the device are recommended.