



RAYSTAR

曜凌光電股份有限公司

住址: 42878 台中市大雅区科雅路 25 號 5F WEB: <http://www.Raystar-Optronics.com>
5F., No.25, Keya Rd., Daya Dist., Taichung E-mail: sales@raystar-optronics.com
City 428, Taiwan Tel:886-4-2565-0761 Fax : 886-4-2565-0760

RG12864C1-FHW-V

SPECIFICATION

CUSTOMER:

APPROVED BY	
PCB VERSION	
DATE	

FOR CUSTOMER USE ONLY

SALES BY	APPROVED BY	CHECKED BY	PREPARED BY

ISSUED DATE:

Contents

	Page
1. Revision History	3
2. General Specification	4
3. Module Classification Information	5
4. Interface Pin Function	6
5. Outline dimension & Block Diagram	7
6. Display Control Instruction	8
7. Timing Characteristics	31
8. Optical Characteristics	34
9. Absolute Maximum Ratings	35
10. Electrical Characteristics	35
11. Backlight Information	36
12. Reliability	37
13. Inspection specification	38
14. Precautions in use of LCD Modules	42
15. Material List of Components for RoHs	43
16. Recommendable storage	43

1. Revision History

DATE	VERSION	REVISED PAGE NO.	Note
2010/1/14	1		First issue
2012/10/16	2	36	Modify Backlight Information
		35	Modify Electrical Characteristics

RAYSTAR OPTRONICS

2. General Specification

The Features of the Module is description as follow:

- Module dimension: 78.0 x 70.0 x 14.3 (max.) mm³
- View area: 62.0 x 44.0 mm²
- Active area: 56.3 x 38.38 mm²
- Number of Dots: 128 x 64
- Dot size: 0.42 x 0.58 mm²
- Dot pitch: 0.44 x 0.60 mm²
- LCD type: FSTN Positive Transflective
- Duty: 1/64
- View direction: 6 o'clock
- Backlight Type: LED White

RAYSTAR OPTRONICS

3. Module Coding System

R	G	12864	C1	-	F	H	W	-	V
1	2	3	4	-	5	6	7	-	8

Item	Description		
1	R : Raystar Optronics Inc.		
2	Display	C : Character Type, G : Graphic Type	
3	Number of dots : 128x64 Dots		
4	Serials code		
5	LCD	P : TN Positive, Gray	
		N : TN Negative,	
		G : STN Positive, Gray	
		Y : STN Positive, Yellow Green	
		B : STN Negative, Blue	
		F : FSTN Positive	
		T : FSTN Negative	
6	Polarizer Type, Temperature range, View direction	A : Reflective, N.T, 6:00	K : Transflective, W.T,12:00
		D : Reflective, N.T, 12:00	1 : Transflective, U.T,6:00
		G : Reflective, W. T, 6:00	4 : Transflective, U.T.12:00
		J : Reflective, W. T, 12:00	C : Transmissive, N.T,6:00
		0 : Reflective, U. T, 6:00	F : Transmissive, N.T,12:00
		3 : Reflective, U. T, 12:00	I : Transmissive, W. T, 6:00
		B : Transflective, N.T,6:00	L : Transmissive, W.T,12:00
		E : Transflective, N.T.12:00	2 : Transmissive, U. T, 6:00
		H:Transflective, W.T,6:00	5 : Transmissive, U.T,12:00
7	Backlight	N : Without backlight	Y : LED, Yellow Green
		P : EL, Blue green	A : LED, Amber
		T : EL, Green	W : LED, White
		D : EL, White	H : LED, High light White
		F : CCFL, White	G : LED, Green
8	Special code	V: Build in Negative Voltage	

4. Interface Pin Function

Pin No.	Symbol	Level	Description
1	V _{EE}		Negative Voltage Output
2	V _{SS}		GND
3	V _{DD}		Power supply
4	V _O		Power supply for LCD driver
5	WR	L	Data write. Write data into RA6963 when WR = L
6	RD	L	Data read. Read data from RA6963 when RD = L
7	CE	L	L : Chip enable
8	C/D	H/L	WR=L , C/D=H : Command Write C/D=L: Data write RD=L , C/D=H : Status Read C/D=L: Data read
9	RESET	H/L	H : Normal ; L : Initialize RA6963
10	DB0	H/L	Data bus line
11	DB1	H/L	Data bus line
12	DB2	H/L	Data bus line
13	DB3	H/L	Data bus line
14	DB4	H/L	Data bus line
15	DB5	H/L	Data bus line
16	DB6	H/L	Data bus line
17	DB7	H/L	Data bus line
18	FS	H/L	Pins for selection of font ; H : 6 * 8 , L : 8 * 8
19	K		Power supply for LED B/L-
20	A		Power supply for LED B/L+

5. Outline Dimension & Block Diagram

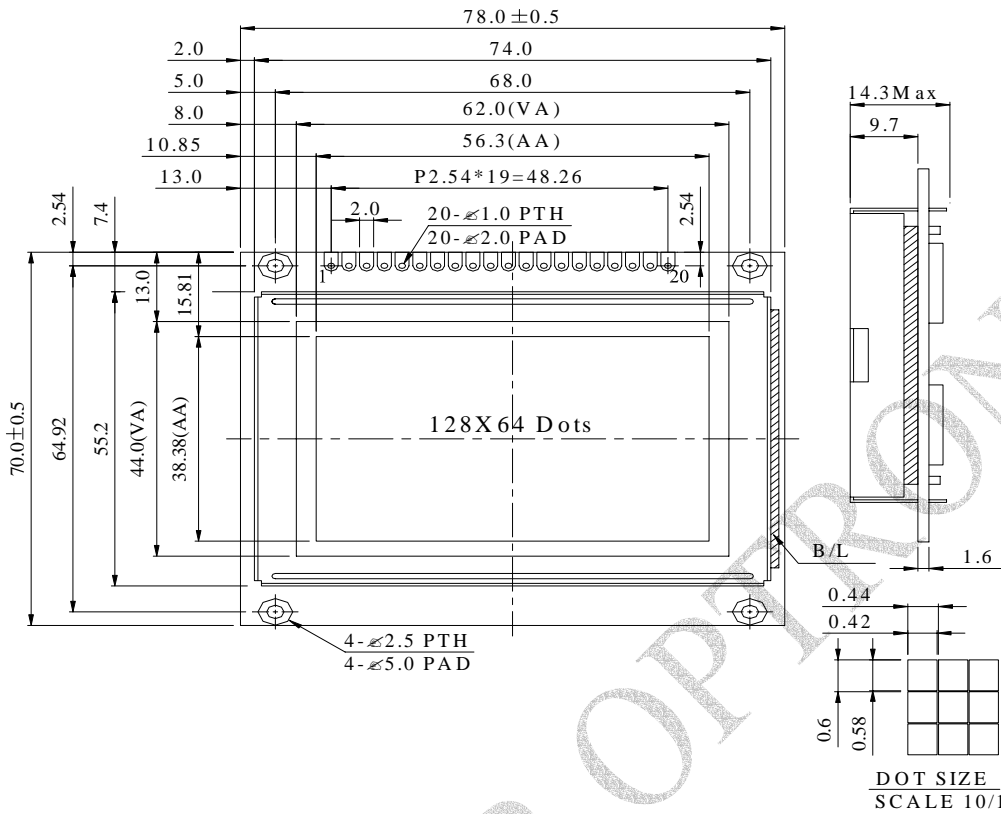

PIN NO.	SYMBOL
1	VEE
2	V _{SS}
3	V _{DD}
4	V _O
5	WR
6	RD
7	CE
8	CD
9	RESET
10	DB0
11	DB1
12	DB2
13	DB3
14	DB4
15	DB5
16	DB6
17	DB7
18	FS
19	K
20	A

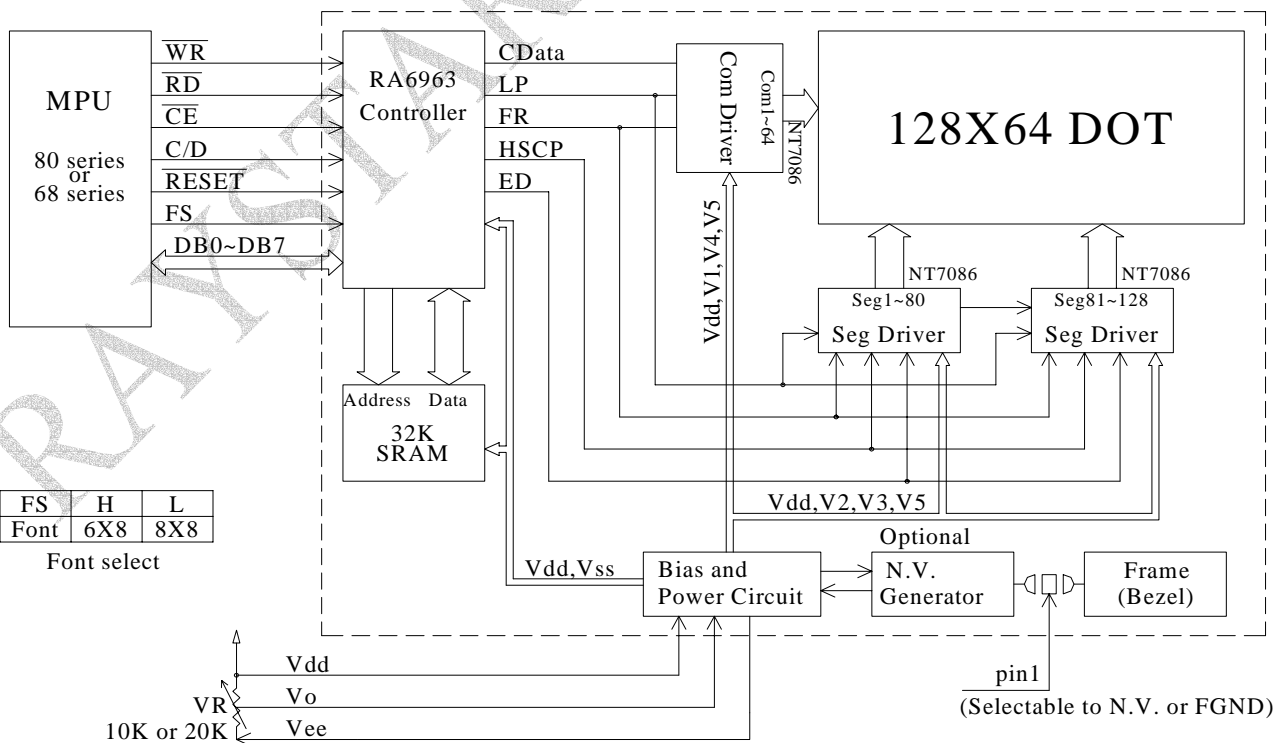

FS	H	L
Font	6X8	8X8

Font select

External contrast adjustment.

6. Display Control Instruction

6.1 Communications with MPU

•Status Read

A status check must be performed before data is read or written.

Status Check

The Status of RA6963 can be read from the data lines.

\overline{RD}	\overline{WR}	\overline{CS}	C/\overline{D}	SD[7:0]
L	H	L	H	Status Word

The RA6963 status word format is as follows:

MSB				LSB			
SD7	SD6	SD5	SD4	SD3	SD2	SD1	SD0
STA7	STA6	STA5	STA4	STA3	STA2	STA1	STA0

STA0	Check command execution capability	0: Disable 1: Enable
STA1	Check data read/write capability	0: Disable 1: Enable
STA2	Check Auto mode data read capability	0: Disable 1: Enable
STA3	Check Auto mode data write capability	0: Disable 1: Enable
STA4	Not used	
STA5	Check controller operation capability	0: Disable 1: Enable
STA6	Error flag. Used for Screen copy commands.	0: No error 1: Error
STA7	Check the blink condition	0: Display off 1: Normal display

Note 1: It is necessary to check STA0 and STA1 at the same time.

There is a possibility of erroneous operation due to a hardware interrupt.

Note 2: For most modes STA0 /STA1 are used as a status check.

Note 3: STA2 and STA3 are valid in Auto mode; STA0 and STA1 are invalid.

Status Checking Flow

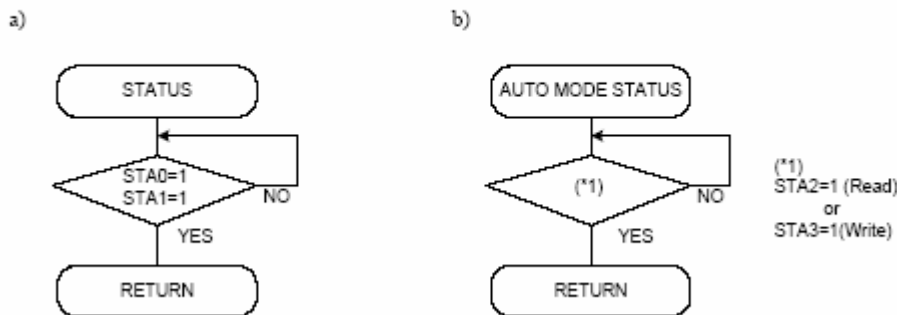

Note 4: When using the MSB=0 command, a Status Read must be performed.

If a status check is not carried out, the RA6963 cannot operate normally, even after a delay time.

The hardware interrupt occurs during the address calculation period (at the end of each line).

If a MSB=0 command is sent to the RA6963 during this period, the RA6963 enters Wait status.

If a status check is not carried out in this state before the next command is sent, there is the possibility that command or data will not be received.

• **Setting Data**

When using the RA6963, first set the data, then set the command.

Procedure for Sending a Command

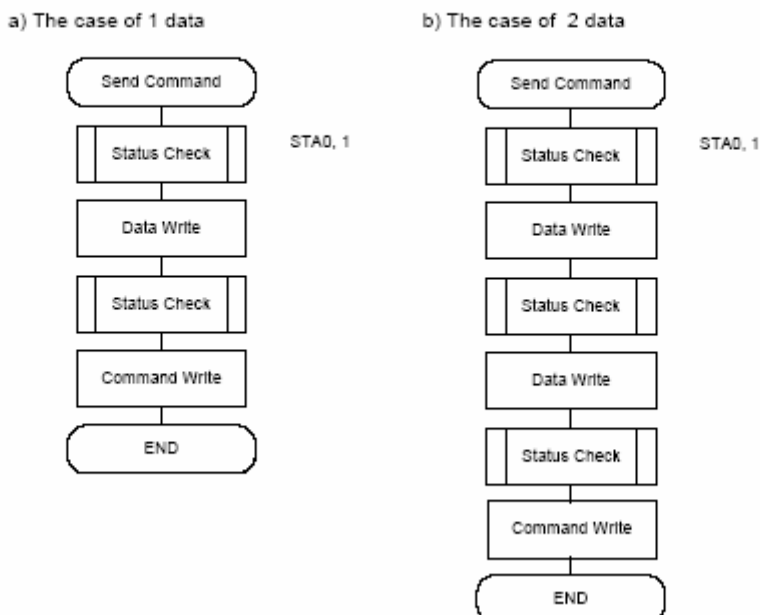

Note: When sending more than two data, the last datum (or last two data) is valid.

• Command Definitions

Command	Code	D1	D2	Function
Registers Setting	00100001	X address	Y address	Set cursor pointer
	00100010	Data	00h	Set Offset Register
	00100100	Low address	High address	Set Address pointer
Set Control Word	01000000	Low address	High address	Set Text Home Address
	01000001	Columns	00h	Set Text Area
	01000010	Low address	High address	Set Graphic Home Address
	01000011	Columns	00h	Set Graphic Area
Mode Set	1000X000	--	--	OR mode
	1000X001	--	--	EXOR mode
	1000X011	--	--	AND mode
	1000X100	--	--	Text Attribute mode
	1000XXX	--	--	Internal CG ROM mode
	10001XXX	--	--	External CG RAM mode
Display Mode	10010000	--	--	Display off
	1001XX10	--	--	Cursor on, blink off
	1001XX11	--	--	Cursor on, blink on
	100101XX	--	--	Text on, graphic off
	100110XX	--	--	Text off, graphic on
	100111XX	--	--	Text on, graphic on
Cursor Pattern Select	10100000	--	--	1-line cursor
	10100001	--	--	2-line cursor
	10100010	--	--	3-line cursor
	10100011	--	--	4-line cursor
	10100100	--	--	5-line cursor
	10100101	--	--	6-line cursor
	10100110	--	--	7-line cursor
	10100111	--	--	8-line cursor
Data Read/Write	11000000	Data	--	Data Write and Increment ADP
	11000001	--	--	Data Read and Increment ADP
	11000010	Data	--	Data Write and Decrement ADP
	11000011	--	--	Data Read and Decrement ADP
	11000100	Data	--	Data Write and Non-variable ADP
	11000101	--	--	Data Read and Non-variable ADP
Data auto Read/Write	10110000	--	--	Set Data Auto Write
	10110001	--	--	Set Data Auto Read
	10110010	--	--	Auto Reset
Screen Peek	11100000	--	--	Screen Peek
Screen Copy	11101000	--	--	Screen Copy
Bit Set/Reset	11110XXX	--	--	Bit Reset
	11111XXX	--	--	Bit Set
	1111X000	--	--	Bit 0 (LSB)
	1111X001	--	--	Bit 1
	1111X010	--	--	Bit 2
	1111X011	--	--	Bit 3
	1111X100	--	--	Bit 4
	1111X101	--	--	Bit 5
	1111X110	--	--	Bit 6
	1111X111	--	--	Bit 7 (MSB)

Screen Reverse	11010000	Data	Data (Don't care) (Note)	Whole screen reverse Data Bit 0 0 : Normal 1 : Reverse
Blink Time	01010000	Data	Data (Don't care) (Note)	If Frame = 60Hz Data Bit 2:0 000 : 0.066s 001 : 0.25s 010 : 0.5s (Default) 011 : 0.75s 100 : 1s 101 : 1.25s 110 : 1.5s 111 : 2s
Cursor Auto Moving	01100000	Data	Data (Don't care) (Note)	Data Bit 0 0 : Disable.(Default) 1 : Enable.
CGROM Font Select	01110000	Data	Data (Don't care) (Note)	Data Bit 1:0 00 : Do not care.(Default) 01 : Do not care. 10 : CGROM Font-01. 11 : CGROM Font-02.

Note : In these functions, it must be sent two data before sending the command, but the contents of the second datum (D2) can be any values.

6.2 Setting Registers

Code	Hex.	Function	D1	D2
00100001	21h	Set Cursor Pointer	X-Adrs	Y-Adrs
00100010	22h	Set Offset Register	Data	00h
00100100	24h	Set Address Pointer	Low Adrs	High Adrs

• Set Cursor Pointer

The X-Adrs and Y-Adrs specify the position of the cursor. The cursor position can only be moved by this command. Data read /write from the MPU never changes the cursor pointer. X-Adrs and Y-Adrs are specified as follows.

X-Adrs 00h to 4Fh (lower 7 bits are valid)
Y-Adrs 00h to 1Fh (lower 5 bits are valid)

a) Single-Scan
X-Adrs 00h to 4Fh

Y-Adrs 00h to 0Fh

b) Dual-Scan
X-Adrs 00h to 4Fh

Y-Adrs 00h to 0Fh
Upper Screen
Y-Adrs 10h to 1Fh
Lower Screen

• **Set Offset Register**

The offset register is used to determine the external character generator RAM area. The RA6963 has a 16-bit address bus as follows:

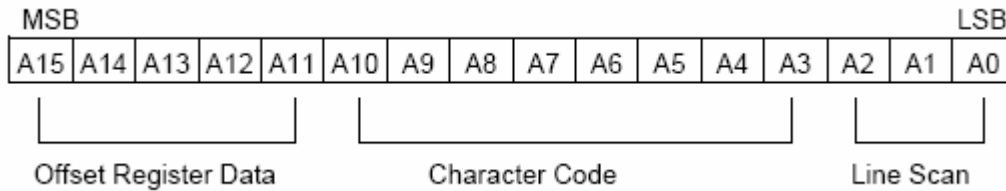

RA6963 assign External character generator, when character code set 80h to FFh in using Internal character generator. Character code 00h to 80h assign External character generator, when External generator mode

The senior five bits define the start address in external memory of the CG RAM area. The next eight bits represent the character code of the character. In internal CG ROM mode, character Codes 00h to 7Fh represent the predefined “internal” CG ROM characters, and codes 80h to FFh Represent the user’s own “external” characters. In external CG RAM mode, all 256 codes from 00h to FFh can be used to represent the user’s own characters. The three least significant bits indicate one of the eight rows of eight dots that define the character’s shape.

The Relationship between Display RAM Address and Offset Register

Offset Register Data	CG RAM hex. Address (Start to End)
00000	0000 to 07FFh
00001	0800 to 0FFFh
00010	1000 to 17FFh
11100	E000 to E7FFh
11101	E800 to EFFFh
11110	F000 to F7FFh
11111	F800 to FFFFh

(Example 1)

Offset Register

02h

Character Code

80h

Character Generator RAM Start Address

0001

0100

0000

0000

1

4

0

0

h

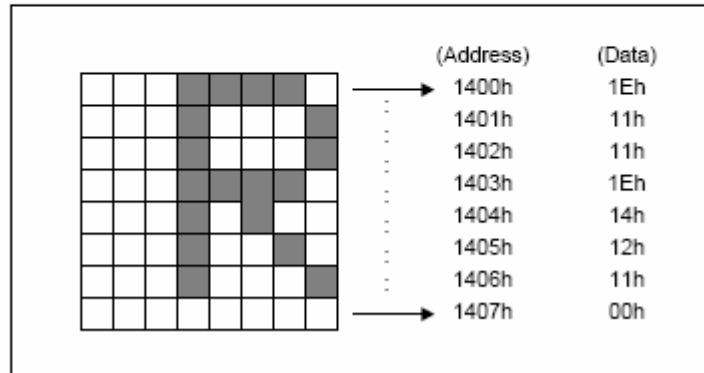

RAYSTAR OPTRO

(Example 2) The relationship between Display RAM data and display characters

	(RAM Data)	(Character)
AB γ DE ζ GH	21h	A
:	22h	B
:	83h	11h
:	24h	D
:	25h	E
:	86h	14h
	27h	G
Display Character	28h	H

The “γ” and “ζ” are displayed by character generator RAM.

• **Set Address Pointer**

The Set Address Pointer command is used to indicate the start address for writing to (or reading from) External RAM.

The Flowchart for Set Address Pointer Command

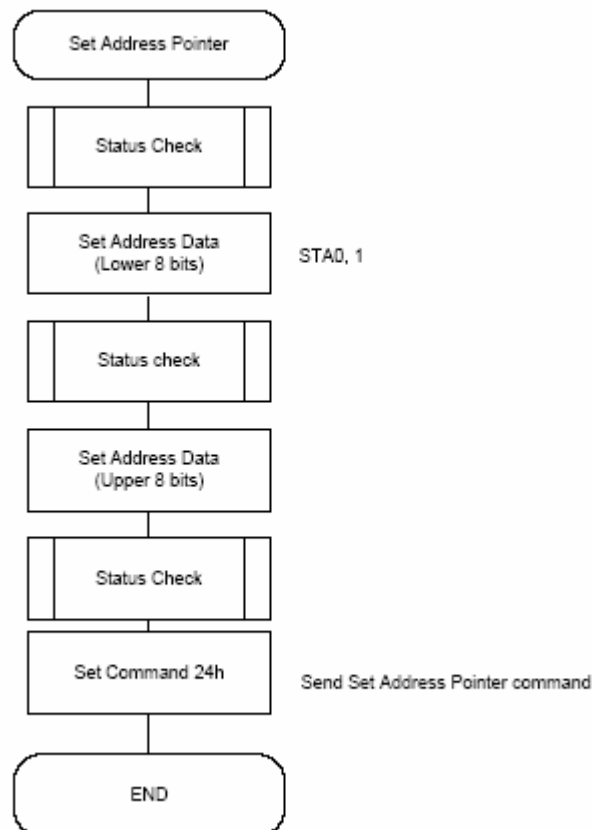

6.3 Set Control Word

Code	Hex.	Function	D1	D2
01000000	40h	Set Text Home Address	Low Address	High Address
01000001	41h	Set Text Area	Columns	00h
01000010	42h	Set Graphic Home Address	Low Address	High Address
01000011	43h	Set Graphic Area	Columns	00h

The home address and column size are defined by this command.

• Set Text Home Address

The starting address in the external display RAM for text display is defined by this command. The text home address indicates the leftmost and uppermost position.

The Relationship between Display RAM Address and Display Position

TH	TH + CL
TH + TA	TH + TA + CL
(TH + TA) + TA	TH + 2TA + CL
(TH + 2TA) + TA	TH + 3TA + CL
⋮	⋮	⋮
⋮	⋮	⋮
⋮	⋮	⋮
⋮	⋮	⋮
TH + (n-1) TA	TH + (n-1) TA + CL

TH: Text home address

TA: Text area number (columns)

CL: Columns are fixed by hardware (pin-programmable).

(Example)

Text Home Address : 0000h
 Text Area : 0020h
 MD2=H, MD3=H : 32 Columns
 $\overline{\text{DUAL}} = \text{H}$, MDS=L, MD0=L, MD1=H : 4 Lines

0000h	0001h	001Eh	001Fh
0020h	0021h	003Eh	002Fh
0040h	0041h	005Eh	005Fh
0060h	0061h	007Eh	007Fh

Set Graphic Home Address

The starting address of the external display RAM used for graphic display is defined by this Command. The graphic home address indicates the leftmost and uppermost position.

The Relationship between External Display RAM Address and Display Position

GH	GH + CL
GH + GA	GH + GA + CL
(GH + GA) + GA	GH + 2GA + CL
(GH + 2GA) + GA	GH + 3GA + CL
:	:	:
:	:	:
:	:	:
:	:	:
GH + (n-1) GA	GH + (n-1) GA + CL

GH: Graphic Home Address
 GA: Graphic Area Number (columns)
 CL: Columns are fixed by hardware (pin-programmable).

(Example)

Graphic Home Address : 0000h
 Graphic Area : 0020h
 MD2=H, MD3=H : 32 columns
DUAL =H, MDS=L, MD0=H, MD1=H : 2 lines

0000h	0001h	001Eh	001Fh
0020h	0021h	003Eh	003Fh
0040h	0041h	005Eh	005Fh
0060h	0061h	007Eh	007Fh
0080h	0081h	009Eh	009Fh
00A0h	00A1h	00BEh	00BFh
00C0h	00C1h	00DEh	00DFh
00E0h	00E1h	00FEh	00FFh
0100h	0101h	011Eh	011Fh
0120h	0121h	013Eh	013Fh
0140h	0141h	015Eh	015Fh
0160h	0161h	017Eh	017Fh
0180h	0181h	019Eh	019Fh
01A0h	01A1h	01BEh	01BFh
01C0h	01C1h	01DEh	01DFh
01E0h	01E1h	01FEh	01FFh

• **Set Text Area**

The display columns are defined by the hardware setting. This command can be used adjust the columns of the display.

(Example)

LCD Size : 20 columns, 4 lines
 Text Home Address : 0000h
 Text Area : 0014h
 MD2=H, MD3=H : 32 columns
 $\overline{\text{DUAL}} = \text{H}$, MDS =L, MD0= L, MD1=H : 4 lines

0000	0001	0013	0014	001F
0014	0015	0027	0028	0033
0028	0029	003B	003C	0047
003C	003D	004F	0050	005B

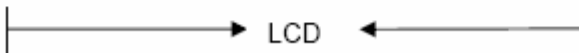

• **Set Graphic Area**

The display columns are defined by the hardware setting. This command can be used to adjust the columns of the graphic display.

(Example)

LCD Size : 20 columns, 2 lines
 Graphic Home Address : 0000h
 Graphic Area : 0014h
 MD2=H, MD3=H : 32 columns
 $\overline{\text{DUAL}} = \text{H}$, MDS=L MD0=H, MD1=H : 2 lines

0000	0001	0013	0014	001F
0014	0015	0027	0028	0033
0028	0029	003B	003C	0047
003C	003D	004F	0050	005B
0050	0051	0063	0064	006F
0064	0065	0077	0078	0083
0078	0079	008B	008C	0097
008C	008D	009F	00A0	00AB
00A0	00A1	00B3	00B4	00BF
00B4	00B5	00C7	00C8	00D3
00C8	00C9	00DB	00DC	00E7
00DC	00DD	00EF	00F0	00FD
00F0	00F1	0103	0104	011F
0104	0105	0127	0128	0123
0128	0129	013B	013C	0147
013C	013D	014F	0150	015B

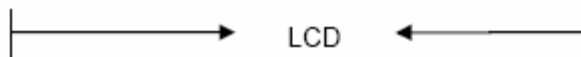

If the graphic area setting is set to match the desired number of columns on the LCD, the addressing scheme will be automatically modified so that the start address of each line equals the end address of the previous line +1.

RAYSTAR OPT

6.4 Mode Set

Code	Function	Operand
1000X000	OR Mode	—
1000X001	EXOR Mode	—
1000X011	AND Mode	—
1000X100	Text Attribute Mode	—
10000XXX	Internal Character Generator Mode	—
10001XXX	External Character Generator Mode	—

X: Invalid

The display mode is defined by this command. The display mode does not change until the next command is sent. The logical OR, EXOR, AND of text or graphic display can be displayed.

In internal Character Generator mode, character codes 00h to 7Fh are assigned to the built-in Character generator ROM. The character codes 80h to FFh are automatically assigned to the external character generator RAM.

(Example)

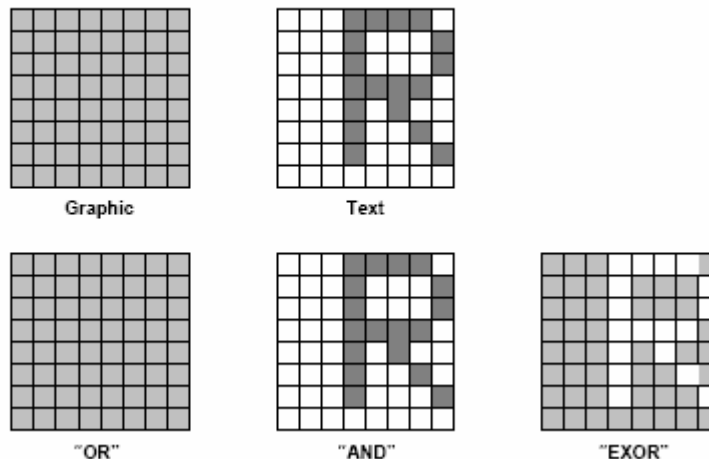

Note: Attribute functions can only be applied to text display, since the attribute data is placed in the graphic RAM area.

Attribute Function

The attribute operations are Reverse display, Character blink, bold and Inhibit. The attribute data is written into the graphic area, which was defined by the Set Control word command. Only text display is possible in Attribute Function mode; graphic display is automatically disabled. However, the Display Mode command must be used to turn both Text and Graphic on that in order to for the Attribute function available.

The attribute data for each character in the text area is written to the same address in the graphic area. The Attribute function is defined as follows.

Attribute RAM 1byte

X	X	X	X	d3	d2	d1	d0
---	---	---	---	----	----	----	----

X: Invalid

< Table 6-15 >

d3	d2	d1	d0	Function
0	0	0	0	Normal Display
0	1	0	1	Reverse Display
0	0	1	1	Inhibit Display
1	0	0	0	Blink of Normal Display
1	1	0	1	Blink of Reverse Display
1	0	1	1	Blink of Inhibit Display
0	1	1	1	Bold Display
1	1	1	1	Blink of Bold Display

6.5 Display Mode

Code	Function	Operand
10010000	Display off	—
1001XX10	Cursor on, Blink off	—
1001XX11	Cursor on, Blink on	—
100101XX	Text on, Graphic off	—
100110XX	Text off, Graphic on	—
100111XX	Text on, Graphic on	—

X: Invalid

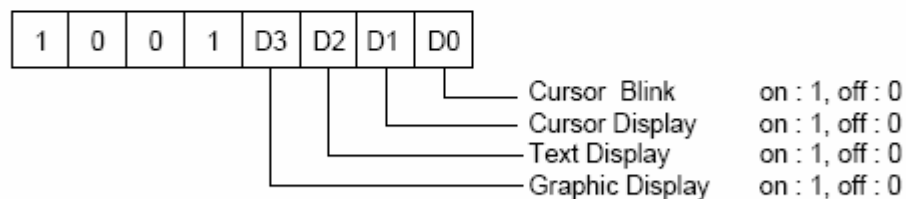

Note: It is necessary to turn on "Text Display" and "Graphic Display" in the following cases.

- a) Combination of text /graphic display
- b) Attribute function

6.6 Cursor Pattern Select

Code	Function	Operand
10100000	1-line cursor	—
10100001	2-line cursor	—
10100010	3-line cursor	—
10100011	4-line cursor	—
10100100	5-line cursor	—
10100101	6-line cursor	—
10100110	7-line cursor	—
10100111	8-line cursor	—

When cursor display is ON, this command selects the cursor pattern in the range 1 line to 8 lines. The cursor address is defined by the Cursor pointer Set command.

6.7 Data Auto Read/Write

Code	Hex.	Function	Operand
10110000	B0h	Set Data Auto Write	—
10110001	B1h	Set Data Auto Read	—
10110010	B2h	Auto Reset	—

This command is convenient for sending a full screen of data from the external display RAM. After Setting Auto mode, a Data Write (or Read) command does not need sent between each datum. A Data Auto Write (or Read) command must be sent after a Set Address Pointer command. After this Command, the address pointer is automatically incremented by 1 after each datum. In Auto mode, the RA6963 cannot accept any other commands.

The Auto Reset command must be sent to the RA6963 after all data has been sent, to clear Auto Mode.

Note: A Status Check for Auto Mode STA2, STA3 should be checked between sending of each datum. Auto Reset should be performed after checking STA3=1 (STA2=1). Refer to the following flowchart.

a) Auto Read mode

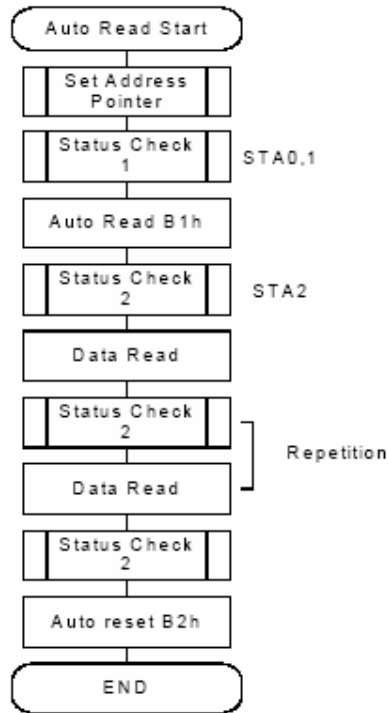

b) Auto Write mode

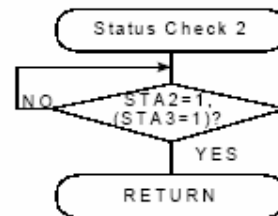
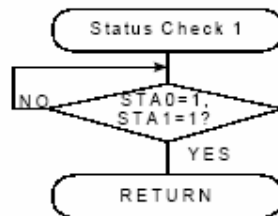
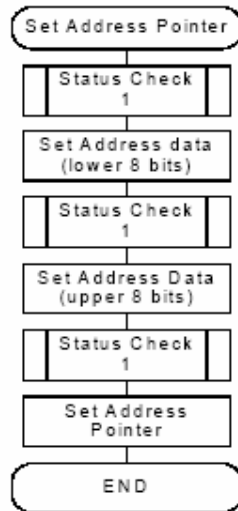
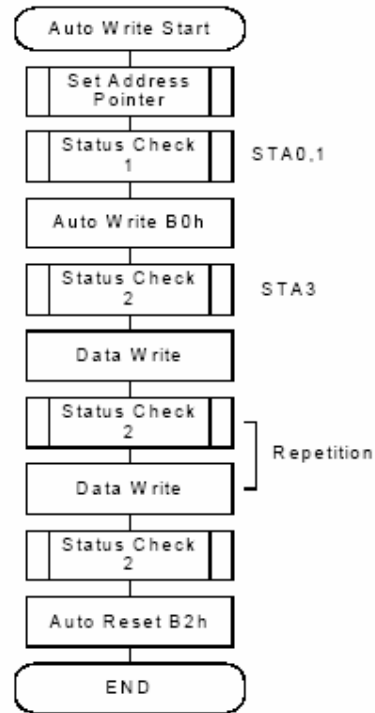

RA

6.8 Data Read/Write

Code	Hex.	Function	Operand
11000000	C0h	Data Write and Increment ADP	Data
11000001	C1h	Data Read and Increment ADP	—
11000010	C2h	Data Write and Decrement ADP	Data
11000011	C3h	Data Write and Decrement ADP	—
11000100	C4h	Data Write and Non-variable ADP	Data
11000101	C5h	Data Read and Non-variable ADP	—

This command is used for writing data from the MPU to external display RAM, and reading data from external display RAM. Data Write / Data Read should be executed after setting address using Set Address Pointer command, The address pointer can be automatically incremented or decremented using this command.

Note: This command is necessary for each 1-byte datum.

Refer to the following flowchart.

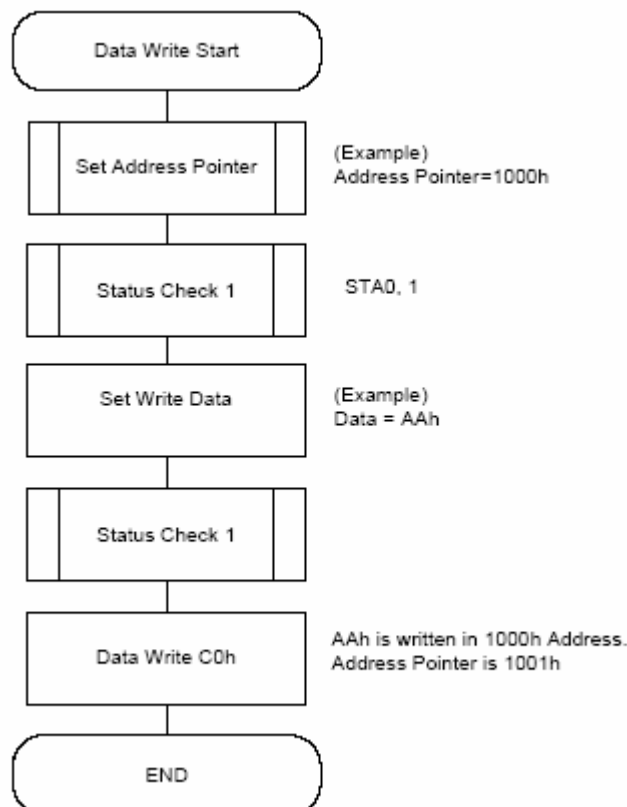

6.9 Screen Peek

Code	Hex.	Function	Operand
11100000	E0h	Screen Peek	—

This command is used to transfer 1 byte of displayed data to the data stack; this byte can be read from the MPU by data access. The logical combination of text and graphic display data on the LCD screen can be read by this command.

The status (STA6) should be checked just after the Screen Peek command. If the address Determined by the Set Address Pointer command is not in the graphic area, this command is ignored and a status flag (STA6) is set.

Refer to the following flowchart.

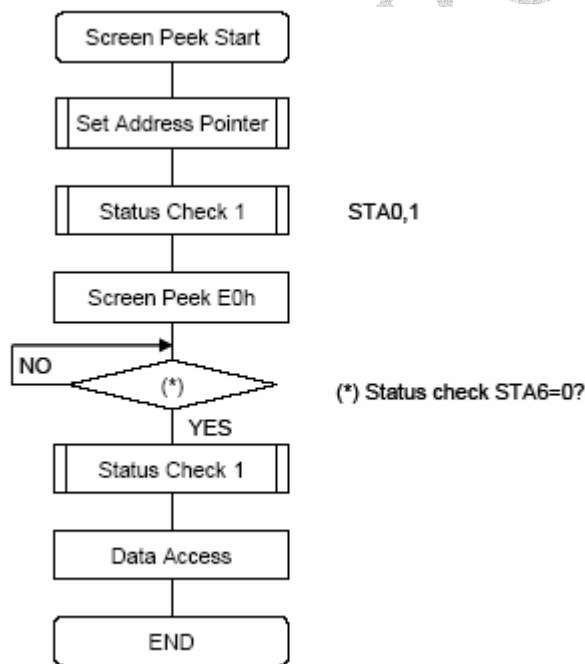

Note: This command is available when hardware column number and software column number are the same. Hardware column number is related to MD2 and MD3 setting. Software column number is related to Set Text Area and Set Graphic Area command.

6--10 Screen Copy

Code	Hex.	Function	Operand
11101000	E8h	Screen Copy	-

This command copies a single raster line of data to the graphic area.

The start point must be set using the Set Address Pointer command.

Note 1: If the attribute function is being used, this command is not available. (With Attribute data is graphic area data.)

Note 2: With Dual-Scan, this command cannot be used (because the RA6963 cannot separate the upper screen data and lower screen data).

Refer to the following flowchart.

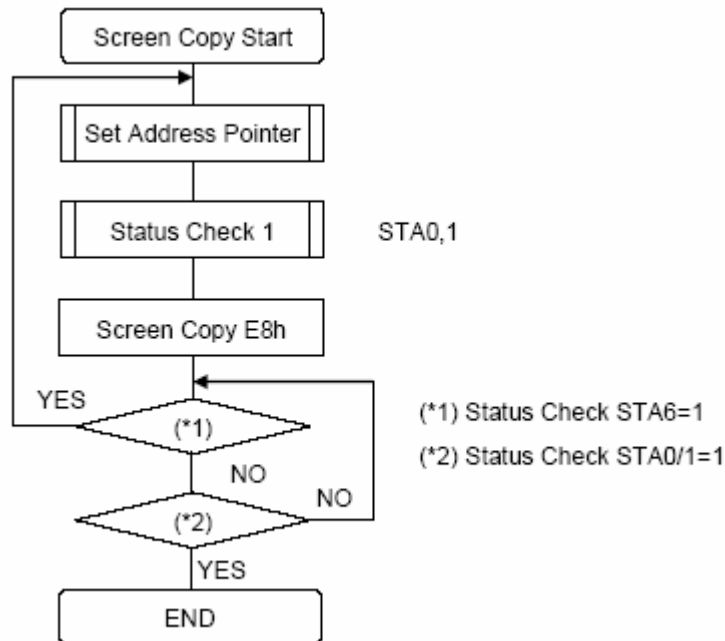

Note: This command is available when hardware column number is the same. Hardware column number is related to MD2 and MD3 setting. Software column number is related to Set Text Area and Set Graphic Area command.

6-11 Bit Set/Reset

Code	Function	Operand
11110XXX	Bit Reset	—
11111XXX	Bit Set	—
1111X000	Bit 0 (LSB)	—
1111X001	Bit 1	—
1111X010	Bit 2	—
1111X011	Bit 3	—
1111X100	Bit 4	—
1111X101	Bit 5	—
1111X110	Bit 6	—
1111X111	Bit 7 (MSB)	—

X: Invalid

This command used to set or reset a bit of the byte specified by the address pointer.

Only one bit can be set / reset at time.

Refer to following flowchart.

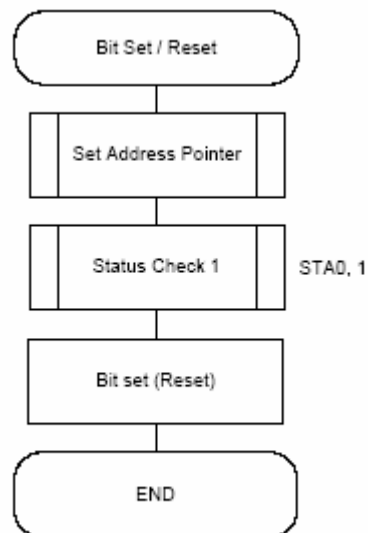

6-12 Screen Reverse

Code	Hex.	Function	D1	D2
11010000	D0h	Enable/Disable the whole screen reversing	Data	-

Screen Reverse Selection (D1)

Bit7	Bit6	Bit5	Bit4	Bit3	Bit2	Bit1	Bit0
x	x	x	x	x	x	x	0/1

Bit0 = 0 : Normally display.

Bit0 = 1 : Reverse the whole screen.

This command (D0h) is used to reverse the displayed data of the whole screen. When this function is enabled, the displayed data on the LCD are reversed to show reversing pattern.

6-13 Blink Time

Code	Hex.	Function	D1	D2
01010000	50h	Adjust the blink time for the blink functions of the RA6963	Data (Bit2~Bit0)	Do not care (Note)

Note : In this function, it must be sent two data before sending the command, but the contents of the second datum (D2) can be any values.

Blink Time Selection (D1)

Bit 2	Bit 1	Bit 0	Blink Time(If $f_R=60\text{Hz}$)
0	0	0	0.066 sec.
0	0	1	0.25 sec.
0	1	0	0.5 sec.
0	1	1	0.75 sec.
1	0	0	1 sec.
1	0	1	1.25 sec.
1	1	0	1.5 sec.
1	1	1	2 sec.

The blink time of the blink functions are adjusted by this command (50h). For example, if the frequency of the frame equals 60Hz, the blink time can be adjusted from 0.066 second to 2 second by using software selections. The selections are listed in the Table 6-26.

6-14 Cursor Auto Moving

Code	Hex.	Function	D1	D2
01100000	60h	Enable/Disable the automatic cursor movement	Data (Bit0)	Do not care (Note)

Note : In this function, it must be sent two data before sending the command, but the contents of the second datum (D2) can be any values.

Cursor Auto Moving Selection (D1)

Bit7	Bit6	Bit5	Bit4	Bit3	Bit2	Bit1	Bit0
x	x	x	x	x	x	x	0/1

Bit0 = 0 : Disable.

Bit0 = 1 : Enable.

The RA6963 provides a unique function for the automatic cursor movement. After writing (reading) each displayed datum, the cursor pointer is automatically increased/decreased by one in the Cursor Auto-Moving mode.

6-15 CGROM Font Select

Code	Hex.	Function	D1	D2
01110000	70h	Change the Character Font Map	Data (Bit1~Bit0)	Do not care (Note)

Note : In this function, it must be sent two data before sending the command, but the contents of the second datum (D2) can be any values.

CGROM Font Selection (D1)

Bit 1	Bit 0	CGROM Font
0	0	Do not care(Default)
0	1	Do not care
1	0	CGROM Font-01.
1	1	CGROM Font-02.

This command (70h) is a convenient function for selecting the Character Font Map. The user can get more built-in characters from CGROM Font-01 or CGROM Font-02, which is determined by software selections. The selections are listed in the Table 6-30.

6-16 Character Font Map

CGROM Font - 01

LSB \ MSB	0	1	2	3	4	5	6	7	8	9	A	B	C	D	E	F
0		!	"	#	\$	%	&	'	()	*	+	,	-	.	/
1	0	1	2	3	4	5	6	7	8	9	:	;	<	=	>	?
2	0	A	B	C	D	E	F	G	H	I	J	K	L	M	N	O
3	P	Q	R	S	T	U	U	W	X	Y	Z	[\]	^	_
4		a	b	c	d	e	f	g	h	i	j	k	l	m	n	o
5	p	q	r	s	t	u	v	w	x	y	z	{		}	~	
6	0	ü	ë	ä	ä	ä	ä	ö	ë	ë	ë	ï	ï	ï	ä	ä
7	ë	æ	æ	ö	ö	ö	ö	ü	ö	ü	ø	ø	¥	¥	¥	¥

CGROM Font - 02

LSB \ MSB	0	1	2	3	4	5	6	7	8	9	A	B	C	D	E	F
0		!	"	#	\$	%	&	'	()	*	+	,	-	.	/
1	0	1	2	3	4	5	6	7	8	9	:	;	<	=	>	?
2	0	A	B	C	D	E	F	G	H	I	J	K	L	M	N	O
3	P	Q	R	S	T	U	U	W	X	Y	Z	[\]	^	_
4	千	万	月	キ	キ	■	ヲ	アイ	ウ	エ	オ	カ	ユ	ヨ	ツ	
5	一	ア	イ	ウ	エ	オ	カ	キ	ク	ケ	コ	サ	シ	ス	セ	ソ
6	タ	チ	ツ	テ	ト	ナ	ニ	ヌ	ネ	ノ	ハ	ヒ	フ	ヘ	ホ	マ
7	ミ	ム	メ	モ	カ	ユ	ヨ	ラ	リ	ル	レ	ロ	ワ	ン	ッ	□

The RA6963 has two part number - RA6963L2NA and RA6963L2NB. The RA6963L2NA is compatible to T6963C(code 0101) and the default font is Figure 6-13 as above. The RA6963L2NB is compatible to T6963C(code 0201) and the default font is Figure 6-14 as above.

Although RA6963 provide a extra internal command for MCU to select both font of above, but you do not need to change the software to select the font that if you chose the right part number.

6-17 RA6963 vs. T6963C

Item	Description	RAiO RA6963	Toshiba T6963C	Note
1	CGROM Font Select	Yes	--	RA6963 provides two CGROMs – Font-01 and Font-02
2	Blink Time Selection	Yes	--	RA6963 provides eight selections for blinking.
3	Cursor Auto Move	Yes	--	
4	Whole Screen Reverse	Yes	--	
5	Bold Text and Blink	Yes	--	RA6963 provides Bold Text feature.
6	Package	LQFP- 67Pin	LQFP- 67Pin	

RAYSTAR OPTRO™

7. Timing Characteristics

MPU Interface Timing

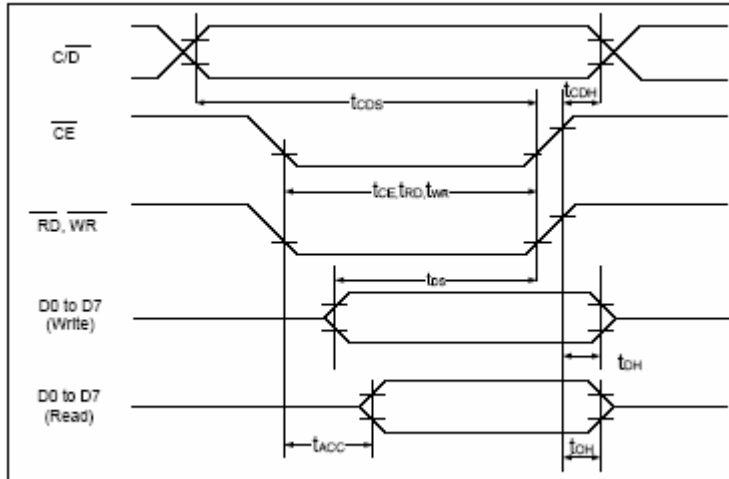

($V_{DD}=+5V\pm 5\%$, $GND=0V$, $T_a = -20$ to $+70^\circ C$)

Item	Symbol	Test Conditions	Min.	Max.	Unit
$\overline{C/D}$ Set Up Time	t_{CDS}	--	100	--	ns
$\overline{C/D}$ Hold Time	t_{CDH}	--	10	--	ns
\overline{CE} , \overline{RD} , \overline{WR} Pulse Width	t_{CE} , t_{RD} , t_{WR}	--	80	--	ns
Data Set Up Time	t_{DS}	--	80	--	ns
Data Hold Time	t_{DH}	--	40	--	ns
Access Time	t_{ACC}	--	--	150	ns
Output Hold Time	t_{OH}	--	10	50	ns

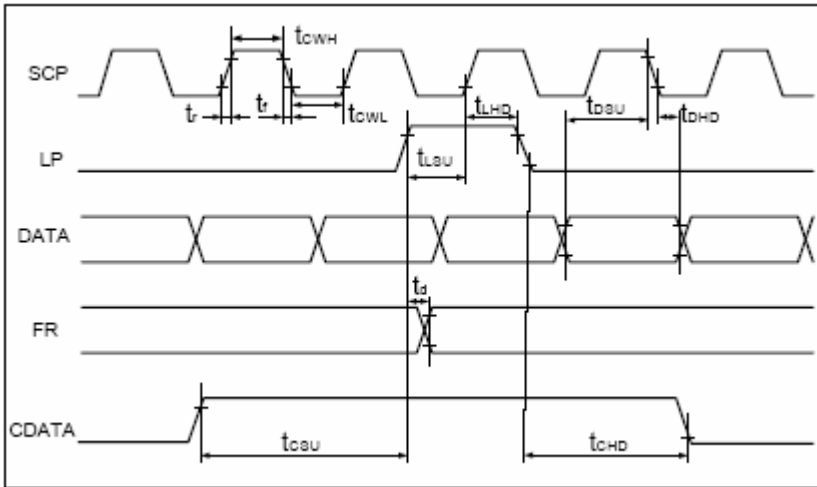
Driver Interface Timing

(VDD=+5V±5%,GND=0V,Ta= -20 to +70°C)

Item	Symbol	Test Conditions	Min.	Max.	Unit
Operating Frequency	f_{SCP}	Ta = -20~70°C	--	9	MHz
SCP Pulse Width	t_{CWH}, t_{CWL}	--	150	--	ns
SCP Rise/Fall Time	t_r, t_f	--	--	30	ns
LP Setup Time	t_{LSU}	--	150	290	ns
LP Hold Time	t_{LHD}	--	5	40	ns
Data Setup Time	t_{DSU}	--	170	--	ns
Data Hold Time	t_{DHD}	--	80	--	ns
FR Delay Time	t_d	--	0	90	ns
CDATA Setup Time	t_{CSU}	--	450	850	ns
CDATA Hold Time	t_{CHD}	--	450	950	ns

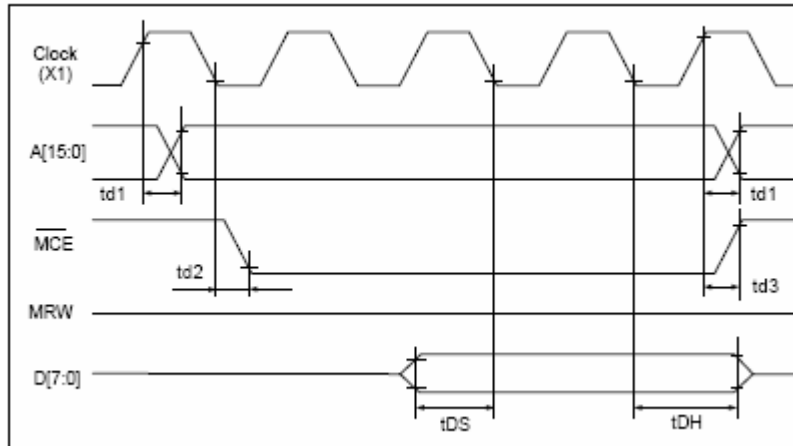
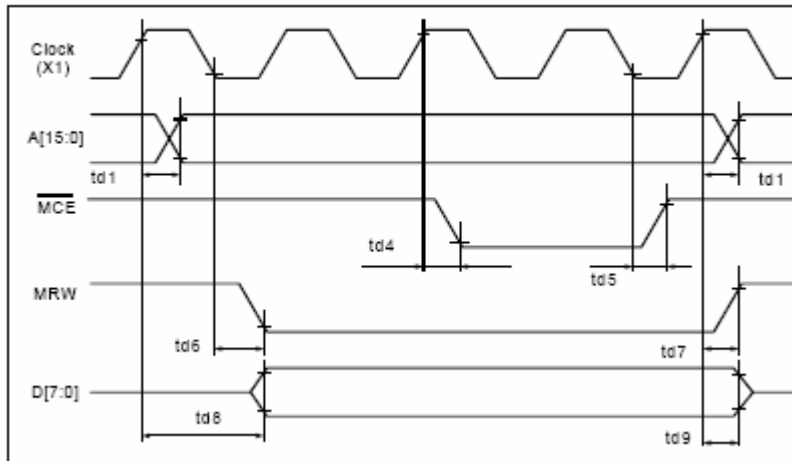
External Memory Interface
External RAM Read

External RAM Write

(VDD=+5V±5%, GND=0V, Ta= -20 to +70°C)

Item	Symbol	Test Conditions	Min.	Max.	Unit
Address Delay Time	t_{d1}	--	--	250	ns
$\overline{\text{MCE}}$ Fall Delay Time(Read)	t_{d2}	--	--	180	ns
$\overline{\text{MCE}}$ Rise Delay Time(Read)	t_{d3}	--	--	180	ns
Data Setup Time	t_{DS}	--	--	--	ns
Data Hold Time	t_{DH}	--	--	--	ns
$\overline{\text{MCE}}$ Fall Delay Time(Write)	t_{d4}	--	--	200	ns
$\overline{\text{MCE}}$ Rise Delay Time(Write)	t_{d5}	--	--	200	ns
MRW Fall Delay Time	t_{d6}	--	--	180	ns
MRW Rise Delay Time	t_{d7}	--	--	180	ns
Data Stable Time	t_{d8}	--	--	450	ns
Data Hold Time	t_{d9}	--	--	200	ns

8. Optical Characteristics

ITEM	SYMBOL	CONDITION	MIN.	TYP.	MAX.	UNIT
View Angle	(V) θ	$CR \geq 2$	30	—	60	deg
	(H) ϕ	$CR \geq 2$	-45	—	45	deg
Contrast Ratio	CR	—	—	5	—	—
Response Time	T rise	—	—	200	300	ms
	T fall	—	—	200	300	ms

8.1 Definitions

View Angles

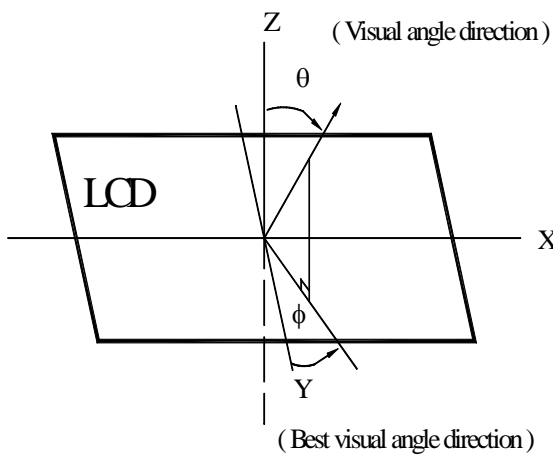

Contrast Ratio

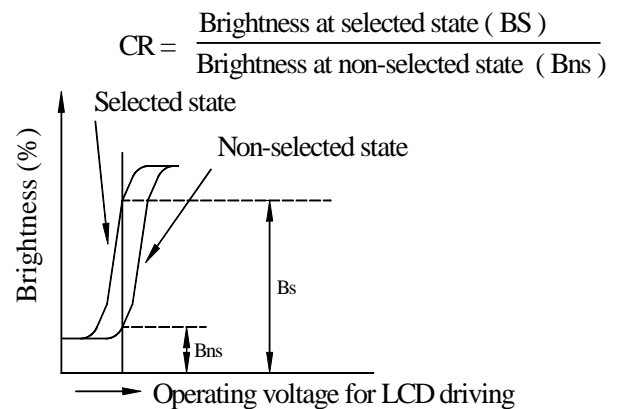

Response Time

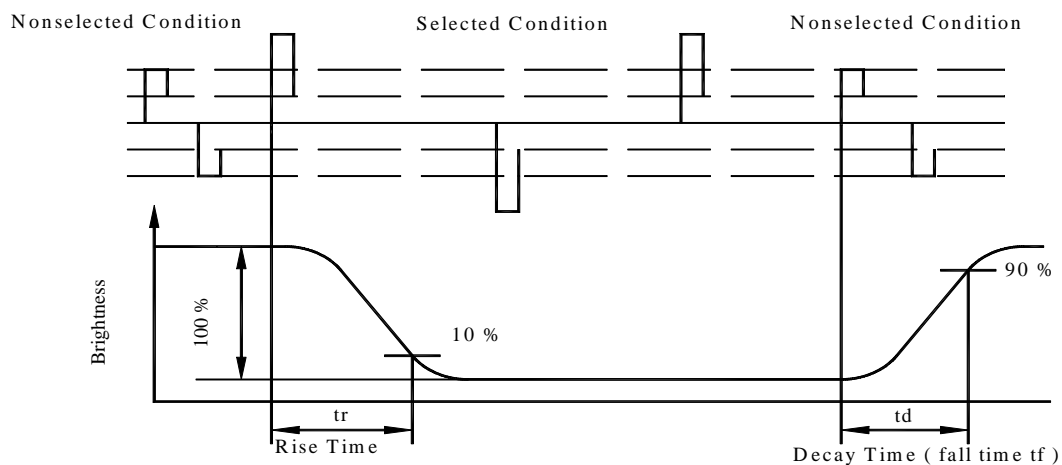

9. Absolute Maximum Ratings

Item	Symbol	Min	Typ	Max	Unit
Operating Temperature	T_{OP}	-20	—	+70	°C
Storage Temperature	T_{ST}	-30	—	+80	°C
Input Voltage	V_I	V_{SS}	—	V_{DD}	V
Supply Voltage For Logic	$V_{DD}-V_{SS}$	-0.3	—	+7	V
Supply Voltage For LCD	$V_{DD}-V_0$	0	—	15	V

10. Electrical Characteristics

Item	Symbol	Condition	Min	Typ	Max	Unit
Supply Voltage For Logic	$V_{DD}-V_{SS}$	—	3.0	—	5.5	V
Supply Voltage For LCD	$V_{DD}-V_0$	$T_a=-20^{\circ}\text{C}$	—	—	9.8	V
		$T_a=25^{\circ}\text{C}$	—	8.5	—	V
		$T_a=+70^{\circ}\text{C}$	7.6	—	—	V
Input High Volt.	V_{IH}	—	$0.8V_{DD}$	—	V_{DD}	V
Input Low Volt.	V_{IL}	—	0	—	$0.2 V_{DD}$	V
Output High Volt.	V_{OH}	—	$V_{DD}-0.3$	—	V_{DD}	V
Output Low Volt.	V_{OL}	—	0	—	0.3	V
Supply Current	I_{DD}	—	11	12	13	mA

11. Backlight Information

Specification

PARAMETER	SYMBOL	MIN	TYP	MAX	UNIT	TEST CONDITION
Supply Current	I _{LED}	—	64	80	mA	V=3.5V
Supply Voltage	V	3.4	3.5	3.6	V	—
Reverse Voltage	V _R	—	—	8	V	—
Luminous Intensity	I _V	460	580	—	CD/M ²	I _{LED} =64mA
Life Time		—	50K	—	Hr.	I _{LED} ≤ 64mA
Color		White				

Note: The LED of B/L is drive by current only, drive voltage is for reference only. drive voltage can make driving current under safety area (current between minimum and maximum).

2. Drive from pin19, pin20

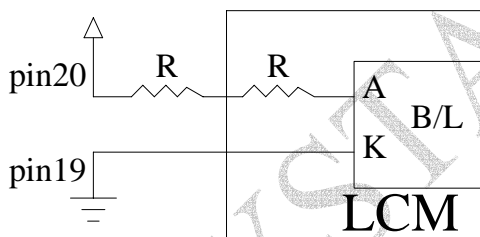

12. Reliability

Content of Reliability Test (wide temperature, -20°C~70°C)

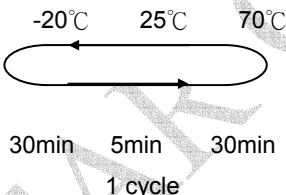
Environmental Test			
Test Item	Content of Test	Test Condition	Note
High Temperature storage	Endurance test applying the high storage temperature for a long time.	80°C 200hrs	2
Low Temperature storage	Endurance test applying the low storage temperature for a long time.	-30°C 200hrs	1,2
High Temperature Operation	Endurance test applying the electric stress (Voltage & Current) and the thermal stress to the element for a long time.	70°C 200hrs	—
Low Temperature Operation	Endurance test applying the electric stress under low temperature for a long time.	-20°C 200hrs	1
High Temperature/ Humidity Operation	The module should be allowed to stand at 60°C,90%RH max For 96hrs under no-load condition excluding the polarizer, Then taking it out and drying it at normal temperature.	60°C,90%RH 96hrs	1,2
Thermal shock resistance	The sample should be allowed stand the following 10 cycles of operation 	-20°C/70°C 10 cycles	—
Vibration test	Endurance test applying the vibration during transportation and using.	Total fixed amplitude : 15mm Vibration Frequency : 10~55Hz One cycle 60 seconds to 3 directions of X,Y,Z for Each 15 minutes	3
Static electricity test	Endurance test applying the electric stress to the terminal.	VS=800V,RS=1.5kΩ CS=100pF 1 time	—

Note1: No dew condensation to be observed.

Note2: The function test shall be conducted after 4 hours storage at the normal Temperature and humidity after remove from the test chamber.

Note3: The packing have to including into the vibration testing.

13. Inspection specification

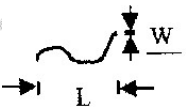
NO	Item	Criterion	AQL												
01	Electrical Testing	1.1 Missing vertical, horizontal segment, segment contrast defect. 1.2 Missing character, dot or icon. 1.3 Display malfunction. 1.4 No function or no display. 1.5 Current consumption exceeds product specifications. 1.6 LCD viewing angle defect. 1.7 Mixed product types. 1.8 Contrast defect.	0.65												
02	Black or white spots on LCD (display only)	2.1 White and black spots on display $\leq 0.25\text{mm}$, no more than three white or black spots present. 2.2 Densely spaced: No more than two spots or lines within 3mm	2.5												
03	LCD black spots, white spots, contamination (non-display)	3.1 Round type : As following drawing $\Phi = (x + y) / 2$	2.5												
		3.2 Line type : (As following drawing)  <table border="1"> <thead> <tr> <th>Length</th> <th>Width</th> <th>Acceptable QTY</th> </tr> </thead> <tbody> <tr> <td>---</td> <td>$W \leq 0.02$</td> <td>Accept no dense</td> </tr> <tr> <td>$L \leq 3.0$</td> <td>$0.02 < W \leq 0.03$</td> <td rowspan="2">2</td> </tr> <tr> <td>$L \leq 2.5$</td> <td>$0.03 < W \leq 0.05$</td> </tr> <tr> <td>---</td> <td>$0.05 < W$</td> <td>As round type</td> </tr> </tbody> </table>	Length	Width	Acceptable QTY	---	$W \leq 0.02$	Accept no dense	$L \leq 3.0$	$0.02 < W \leq 0.03$	2	$L \leq 2.5$	$0.03 < W \leq 0.05$	---	$0.05 < W$
Length	Width	Acceptable QTY													
---	$W \leq 0.02$	Accept no dense													
$L \leq 3.0$	$0.02 < W \leq 0.03$	2													
$L \leq 2.5$	$0.03 < W \leq 0.05$														
---	$0.05 < W$	As round type													
04	Polarizer bubbles	If bubbles are visible, judge using black spot specifications, not easy to find, must check in specify direction. <table border="1"> <thead> <tr> <th>Size Φ</th> <th>Acceptable QTY</th> </tr> </thead> <tbody> <tr> <td>$\Phi \leq 0.20$</td> <td>Accept no dense</td> </tr> <tr> <td>$0.20 < \Phi \leq 0.50$</td> <td>3</td> </tr> <tr> <td>$0.50 < \Phi \leq 1.00$</td> <td>2</td> </tr> <tr> <td>$1.00 < \Phi$</td> <td>0</td> </tr> <tr> <td>Total QTY</td> <td>3</td> </tr> </tbody> </table>	Size Φ	Acceptable QTY	$\Phi \leq 0.20$	Accept no dense	$0.20 < \Phi \leq 0.50$	3	$0.50 < \Phi \leq 1.00$	2	$1.00 < \Phi$	0	Total QTY	3	2.5
Size Φ	Acceptable QTY														
$\Phi \leq 0.20$	Accept no dense														
$0.20 < \Phi \leq 0.50$	3														
$0.50 < \Phi \leq 1.00$	2														
$1.00 < \Phi$	0														
Total QTY	3														

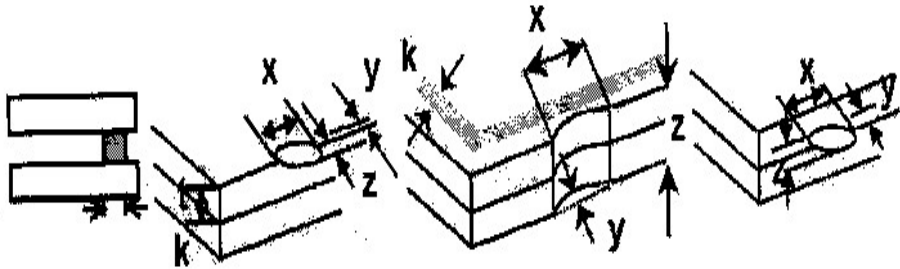
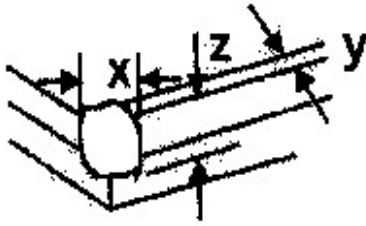
NO	Item	Criterion	AQL																		
05	Scratches	Follow NO.3 LCD black spots, white spots, contamination																			
06	Chipped glass	<p>Symbols Define: x: Chip length y: Chip width z: Chip thickness k: Seal width t: Glass thickness a: LCD side length L: Electrode pad length:</p> <p>6.1 General glass chip : 6.1.1 Chip on panel surface and crack between panels:</p>  <table border="1" data-bbox="443 1034 1353 1191"> <thead> <tr> <th>z: Chip thickness</th> <th>y: Chip width</th> <th>x: Chip length</th> </tr> </thead> <tbody> <tr> <td>$Z \leq 1/2t$</td> <td>Not over viewing area</td> <td>$x \leq 1/8a$</td> </tr> <tr> <td>$1/2t < z \leq 2t$</td> <td>Not exceed 1/3k</td> <td>$x \leq 1/8a$</td> </tr> </tbody> </table> <p>⊙ If there are 2 or more chips, x is total length of each chip.</p> <p>6.1.2 Corner crack:</p>  <table border="1" data-bbox="443 1568 1353 1724"> <thead> <tr> <th>z: Chip thickness</th> <th>y: Chip width</th> <th>x: Chip length</th> </tr> </thead> <tbody> <tr> <td>$Z \leq 1/2t$</td> <td>Not over viewing area</td> <td>$x \leq 1/8a$</td> </tr> <tr> <td>$1/2t < z \leq 2t$</td> <td>Not exceed 1/3k</td> <td>$x \leq 1/8a$</td> </tr> </tbody> </table> <p>⊙ If there are 2 or more chips, x is the total length of each chip.</p>	z: Chip thickness	y: Chip width	x: Chip length	$Z \leq 1/2t$	Not over viewing area	$x \leq 1/8a$	$1/2t < z \leq 2t$	Not exceed 1/3k	$x \leq 1/8a$	z: Chip thickness	y: Chip width	x: Chip length	$Z \leq 1/2t$	Not over viewing area	$x \leq 1/8a$	$1/2t < z \leq 2t$	Not exceed 1/3k	$x \leq 1/8a$	2.5
z: Chip thickness	y: Chip width	x: Chip length																			
$Z \leq 1/2t$	Not over viewing area	$x \leq 1/8a$																			
$1/2t < z \leq 2t$	Not exceed 1/3k	$x \leq 1/8a$																			
z: Chip thickness	y: Chip width	x: Chip length																			
$Z \leq 1/2t$	Not over viewing area	$x \leq 1/8a$																			
$1/2t < z \leq 2t$	Not exceed 1/3k	$x \leq 1/8a$																			

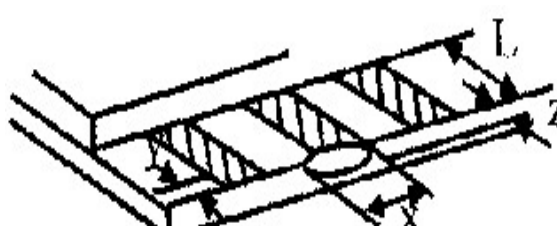
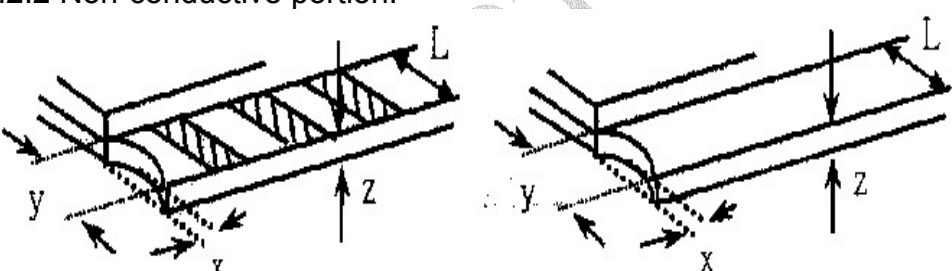
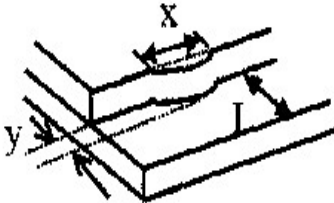
NO	Item	Criterion	AQL																
06	Glass crack	<p>Symbols :</p> <p>x: Chip length y: Chip width z: Chip thickness k: Seal width t: Glass thickness a: LCD side length L: Electrode pad length</p> <p>6.2 Protrusion over terminal :</p> <p>6.2.1 Chip on electrode pad :</p>  <table border="1" data-bbox="343 918 1252 996"> <tr> <td>y: Chip width</td> <td>x: Chip length</td> <td>z: Chip thickness</td> </tr> <tr> <td>$y \leq 0.5\text{mm}$</td> <td>$x \leq 1/8a$</td> <td>$0 < z \leq t$</td> </tr> </table> <p>6.2.2 Non-conductive portion:</p>  <table border="1" data-bbox="414 1321 1252 1444"> <tr> <td>y: Chip width</td> <td>x: Chip length</td> <td>z: Chip thickness</td> </tr> <tr> <td>$y \leq L$</td> <td>$x \leq 1/8a$</td> <td>$0 < z \leq t$</td> </tr> </table> <ul style="list-style-type: none"> ⊙ If the chipped area touches the ITO terminal, over 2/3 of the ITO must remain and be inspected according to electrode terminal specifications. ⊙ If the product will be heat sealed by the customer, the alignment mark not be damaged. <p>6.2.3 Substrate protuberance and internal crack.</p>  <table border="1" data-bbox="750 1691 1260 1769"> <tr> <td>y: width</td> <td>x: length</td> </tr> <tr> <td>$y \leq 1/3L$</td> <td>$x \leq a$</td> </tr> </table>	y: Chip width	x: Chip length	z: Chip thickness	$y \leq 0.5\text{mm}$	$x \leq 1/8a$	$0 < z \leq t$	y: Chip width	x: Chip length	z: Chip thickness	$y \leq L$	$x \leq 1/8a$	$0 < z \leq t$	y: width	x: length	$y \leq 1/3L$	$x \leq a$	2.5
y: Chip width	x: Chip length	z: Chip thickness																	
$y \leq 0.5\text{mm}$	$x \leq 1/8a$	$0 < z \leq t$																	
y: Chip width	x: Chip length	z: Chip thickness																	
$y \leq L$	$x \leq 1/8a$	$0 < z \leq t$																	
y: width	x: length																		
$y \leq 1/3L$	$x \leq a$																		

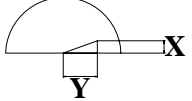
NO	Item	Criterion	AQL
07	Cracked glass	The LCD with extensive crack is not acceptable.	2.5
08	Backlight elements	8.1 Illumination source flickers when lit. 8.2 Spots or scratched that appear when lit must be judged. Using LCD spot, lines and contamination standards. 8.3 Backlight doesn't light or color wrong.	0.65 2.5 0.65
09	Bezel	9.1 Bezel may not have rust, be deformed or have fingerprints, stains or other contamination. 9.2 Bezel must comply with job specifications.	2.5 0.65
10	PCB · COB	10.1 COB seal may not have pinholes larger than 0.2mm or contamination. 10.2 COB seal surface may not have pinholes through to the IC. 10.3 The height of the COB should not exceed the height indicated in the assembly diagram. 10.4 There may not be more than 2mm of sealant outside the seal area on the PCB. And there should be no more than three places. 10.5 No oxidation or contamination PCB terminals. 10.6 Parts on PCB must be the same as on the production characteristic chart. There should be no wrong parts, missing parts or excess parts. 10.7 The jumper on the PCB should conform to the product characteristic chart. 10.8 If solder gets on bezel tab pads, LED pad, zebra pad or screw hold pad, make sure it is smoothed down. 10.9 The Scraping testing standard for Copper Coating of PCB  $X * Y \leq 2\text{mm}^2$	2.5 2.5 0.65 2.5 2.5 0.65 0.65 2.5 2.5
11	Soldering	11.1 No un-melted solder paste may be present on the PCB. 11.2 No cold solder joints, missing solder connections, oxidation or icicle. 11.3 No residue or solder balls on PCB. 11.4 No short circuits in components on PCB.	2.5 2.5 2.5 0.65

NO	Item	Criterion	AQL
12	General appearance	12.1 No oxidation, contamination, curves or, bends on interface Pin (OLB) of TCP.	2.5
		12.2 No cracks on interface pin (OLB) of TCP.	0.65
		12.3 No contamination, solder residue or solder balls on product.	2.5
		12.4 The IC on the TCP may not be damaged, circuits.	2.5
		12.5 The uppermost edge of the protective strip on the interface pin must be present or look as if it cause the interface pin to sever.	2.5
		12.6 The residual rosin or tin oil of soldering (component or chip component) is not burned into brown or black color.	2.5
		12.7 Sealant on top of the ITO circuit has not hardened.	0.65
		12.8 Pin type must match type in specification sheet.	0.65
		12.9 LCD pin loose or missing pins.	0.65
		12.10 Product packaging must the same as specified on packaging specification sheet.	0.65
		12.11 Product dimension and structure must conform to product specification sheet.	0.65

14. Precautions in use of LCD Modules

- (1) Avoid applying excessive shocks to the module or making any alterations or modifications to it.
- (2) Don't make extra holes on the printed circuit board, modify its shape or change the components of LCD module.
- (3) Don't disassemble the LCM.
- (4) Don't operate it above the absolute maximum rating.
- (5) Don't drop, bend or twist LCM.
- (6) Soldering: only to the I/O terminals.
- (7) Storage: please storage in anti-static electricity container and clean environment.
- (8) Raystar have the right to change the passive components
(Resistors, capacitors and other passive components will have different appearance and color caused by the different supplier.)
- (9) Raystar have the right to change the PCB Rev.

15. Material List of Components for RoHs

1. RAYSTAR Optronics Co., Ltd. hereby declares that all of or part of products, including, but not limited to, the LCM, accessories or packages, manufactured and/or delivered to your company (including your subsidiaries and affiliated company) directly or indirectly by our company (including our subsidiaries or affiliated companies) do not intentionally contain any of the substances listed in all applicable EU directives and regulations, including the following substances.

Exhibit A : The Harmful Material List

Material	(Cd)	(Pb)	(Hg)	(Cr6+)	PBBs	PBDEs
Limited Value	100 ppm	1000 ppm	1000 ppm	1000 ppm	1000 ppm	1000 ppm
Above limited value is set up according to RoHS.						

2. Process for RoHS requirement :

- (1) Use the Sn/Ag/Cu soldering surface ; the surface of Pb-free solder is rougher than we used before.
- (2) Heat-resistance temp. :
 Reflow : 250°C ,30 seconds Max. ;
 Connector soldering wave or hand soldering : 320°C , 10 seconds max.
- (3) Temp. curve of reflow, max. Temp. : 235±5°C ;
 Recommended customer's soldering temp. of connector : 280°C , 3 seconds.

16. Recommendable storage

1. Place the panel or module in the temperature 25°C±5°C and the humidity below 65% RH
2. Do not place the module near organics solvents or corrosive gases.
3. Do not crush, shake, or jolt the module

LCM Sample Estimate Feedback Sheet

Module Number : _____

1 、 Panel Specification :

1. Panel Type :	<input type="checkbox"/> Pass	<input type="checkbox"/> NG , _____
2. View Direction :	<input type="checkbox"/> Pass	<input type="checkbox"/> NG , _____
3. Numbers of Dots :	<input type="checkbox"/> Pass	<input type="checkbox"/> NG , _____
4. View Area :	<input type="checkbox"/> Pass	<input type="checkbox"/> NG , _____
5. Active Area :	<input type="checkbox"/> Pass	<input type="checkbox"/> NG , _____
6. Operating Temperature :	<input type="checkbox"/> Pass	<input type="checkbox"/> NG , _____
7. Storage Temperature :	<input type="checkbox"/> Pass	<input type="checkbox"/> NG , _____
8. Others :	_____	

2 、 Mechanical Specification :

1. PCB Size :	<input type="checkbox"/> Pass	<input type="checkbox"/> NG , _____
2. Frame Size :	<input type="checkbox"/> Pass	<input type="checkbox"/> NG , _____
3. Material of Frame :	<input type="checkbox"/> Pass	<input type="checkbox"/> NG , _____
4. Connector Position :	<input type="checkbox"/> Pass	<input type="checkbox"/> NG , _____
5. Fix Hole Position :	<input type="checkbox"/> Pass	<input type="checkbox"/> NG , _____
6. Backlight Position :	<input type="checkbox"/> Pass	<input type="checkbox"/> NG , _____
7. Thickness of PCB :	<input type="checkbox"/> Pass	<input type="checkbox"/> NG , _____
8. Height of Frame to PCB :	<input type="checkbox"/> Pass	<input type="checkbox"/> NG , _____
9. Height of Module :	<input type="checkbox"/> Pass	<input type="checkbox"/> NG , _____
10. Others :	<input type="checkbox"/> Pass	<input type="checkbox"/> NG , _____

3 、 Relative Hole Size :

1. Pitch of Connector :	<input type="checkbox"/> Pass	<input type="checkbox"/> NG , _____
2. Hole size of Connector :	<input type="checkbox"/> Pass	<input type="checkbox"/> NG , _____
3. Mounting Hole size :	<input type="checkbox"/> Pass	<input type="checkbox"/> NG , _____
4. Mounting Hole Type :	<input type="checkbox"/> Pass	<input type="checkbox"/> NG , _____
5. Others :	<input type="checkbox"/> Pass	<input type="checkbox"/> NG , _____

4 、 Backlight Specification :

1. B/L Type :	<input type="checkbox"/> Pass	<input type="checkbox"/> NG , _____
2. B/L Color :	<input type="checkbox"/> Pass	<input type="checkbox"/> NG , _____
3. B/L Driving Voltage (Reference for LED Type) :	<input type="checkbox"/> Pass	<input type="checkbox"/> NG , _____
4. B/L Driving Current :	<input type="checkbox"/> Pass	<input type="checkbox"/> NG , _____
5. Brightness of B/L :	<input type="checkbox"/> Pass	<input type="checkbox"/> NG , _____
6. B/L Solder Method :	<input type="checkbox"/> Pass	<input type="checkbox"/> NG , _____
7. Others :	<input type="checkbox"/> Pass	<input type="checkbox"/> NG , _____

>> Go to page 2 <<

Module Number : _____		
5 · <u>Electronic Characteristics of Module :</u>		
1.Input Voltage :	<input type="checkbox"/> Pass	<input type="checkbox"/> NG , _____
2.Supply Current :	<input type="checkbox"/> Pass	<input type="checkbox"/> NG , _____
3.Driving Voltage for LCD :	<input type="checkbox"/> Pass	<input type="checkbox"/> NG , _____
4.Contrast for LCD :	<input type="checkbox"/> Pass	<input type="checkbox"/> NG , _____
5.B/L Driving Method :	<input type="checkbox"/> Pass	<input type="checkbox"/> NG , _____
6.Negative Voltage Output :	<input type="checkbox"/> Pass	<input type="checkbox"/> NG , _____
7.Interface Function :	<input type="checkbox"/> Pass	<input type="checkbox"/> NG , _____
8.LCD Uniformity :	<input type="checkbox"/> Pass	<input type="checkbox"/> NG , _____
9.ESD test :	<input type="checkbox"/> Pass	<input type="checkbox"/> NG , _____
10.Others :	<input type="checkbox"/> Pass	<input type="checkbox"/> NG , _____
6 · <u>Summary :</u>		
<p style="text-align: center; font-size: 2em; opacity: 0.2; transform: rotate(-30deg);">RAYSTAR OPTRONICS</p> <p>Sales signature : _____</p> <p>Customer Signature : _____ Date : / /</p>		