

Application:	Telecommunication and Data transmitting
Product Features:	Low hold current, Solid state
Operation Current:	0.08 A~0.40A
Maximum Operation Voltage:	60/100/250VDC
Maximum Interrupt Voltage:	250/600VAC
Temperature Range:	-40°C to 85°C
Agency Recognition:	UL, C-UL, TÜV

Electrical Characteristics (23°C)

Part Number	Hold Current	Trip Current	Max. Time to Trip		Max. Current	Max. Operating Voltage	Max. Interrupt Voltage	Typical Power	Resistance Tolerance	
			A	SEC					RMIN	R1MAX
	IH, A	IT, A	A	SEC	IMAX, A	VMAX, VDC	VIMAX, V	Pd, W	ohms	ohms
RH080-250V	0.08	0.16	0.35	4.0	3.0	100	250	1.0	14.0	33.0
RH110-250V	0.11	0.22	1.00	2.0	3.0	100	250	1.0	5.00	16.00
RH120-250V	0.12	0.24	1.00	2.0	3.0	100	250	1.0	4.00	16.00
RH145-250V	0.15	0.29	1.00	2.5	3.0	100	250	1.0	3.00	12.00
RH180-250X	0.18	0.65	3.00	2.0	10.0	100	250	1.5	0.80	4.00
RH150-600M	0.15	0.30	1.00	4.0	3.0	250	600	1.0	6.00	17.00
RH160-600M	0.16	0.32	1.00	7.0	3.0	250	600	1.0	4.00	16.00
RH160-600V	0.16	0.32	1.00	7.0	3.0	250	600	1.0	4.00	18.00
RH200-600V	0.20	0.40	1.00	12.0	3.0	250	600	1.0	4.00	13.50
RH250-600V	0.25	0.86	3.00	1.0	3.0	250	600	1.0	1.00	7.00
RH400-600	0.40	1.00	3.00	4.0	3.0	60	600	1.0	0.95	1.90

IH=Hold current-maximum current at which the device will not trip at 23°C still air.
 IT=Trip current-minimum current at which the device will always trip at 23°C still air.
 V MAX=Maximum voltage device can withstand without damage at its rated current.
 V-IMAX=Maximum interrupt voltage device can withstand for short period of time.(not long term.)
 IMAX= Maximum fault current device can withstand without damage at rated voltage (V max).
 Pd=Typical power dissipated from device when in the tripped state in 23°C still air environment.
 RMIN=Minimum device resistance at 23°C.
 R1MAX=Maximum device resistance at 23°C, 1 hour after tripping .

Physical specifications:

Lead material: Tin plated copper, 22 AWg

Soldering characteristics: MIL-STD-202, Method 208E.

Insulating coating:Flame retardant epoxy, meet UL-94V-0 requirement.

NOTE : All RH products are designed to assist equipment to pass ITU, UL1950 or GR1089 specification.

RH150-600M and RH160-600V meet UL497A Overvoltage and Endurance Conditioning requirements for Thermistor type.

CAUTION : RH devices are not intended for continuous use of Line Voltage such as 120 VAC ~ 240VAC and above.

RH Product Dimensions (Millimeters)

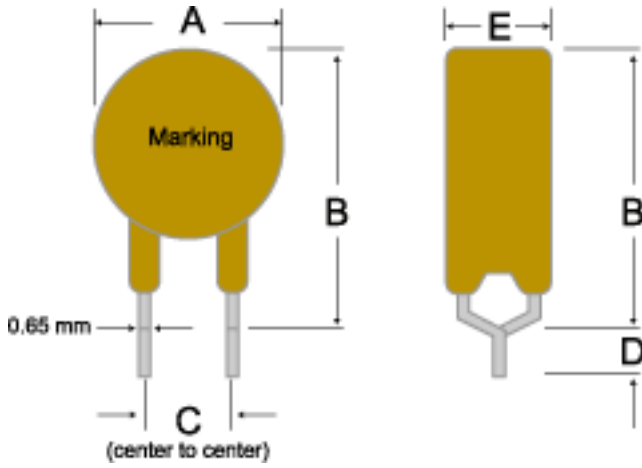

Figure 1
Lead Size: 22AWG,
Ø 0.65 mm Diameter

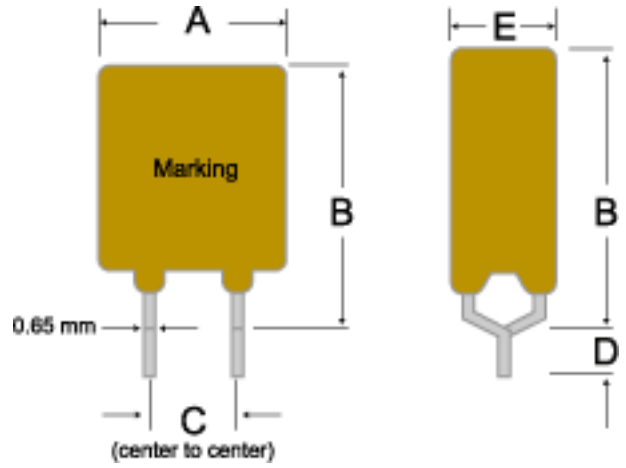
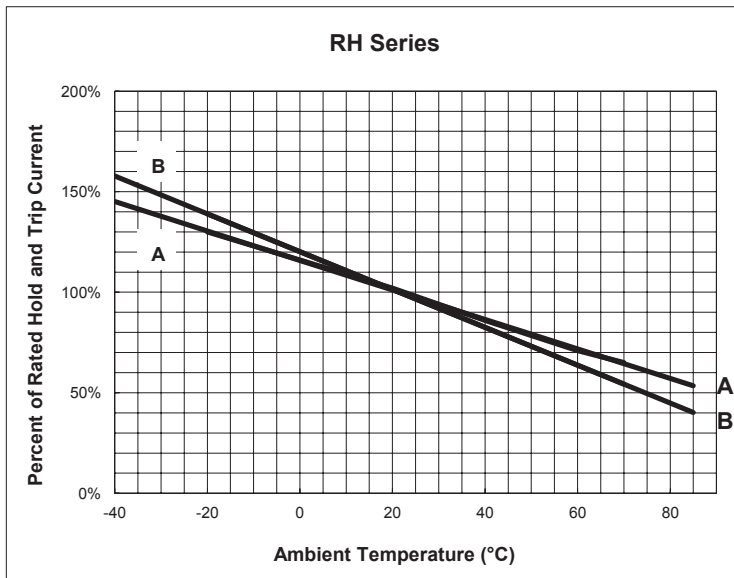

Figure 2
Lead Size: 22AWG,
Ø 0.65 mm Diameter

Part Number	Fig	A	B	C	D	E
		Maximum	Maximum	Typical	Maximum	Maximum
RH080-250V	1	5.8	9.6	5.0	4.7	4.6
RH110-250V	1	6.8	9.9	5.0	4.7	4.6
RH120-250V	2	6.5	11.0	5.0	4.7	4.6
RH145-250V	2	6.5	11.0	5.0	4.7	4.6
RH180-250X	1	9.0	12.0	5.0	4.7	3.8
RH150-600M	2	9.0	12.5	5.0	4.7	4.6
RH160-600M	2	9.0	12.5	5.0	4.7	4.6
RH160-600V	2	16.0	12.6	5.0	4.7	6.0
RH200-600V	2	12.0	14.0	5.0	4.7	6.0
RH250-600V	2	12.0	15.0	5.0	4.7	6.0
RH400-600	2	15.0	14.5	5.0	4.7	6.0

Thermal Derating Curve



A = RH180-250X
B = All other RH devices

Typical Time-To-Trip at 23°C

- A = RH080-250V
- B = RH110-250V
- C = RH120-250V
- D = RH145-250V
- E = RH160-600V
- F = RH200-600V
- G = RH250-600V
- H = RH400-600V

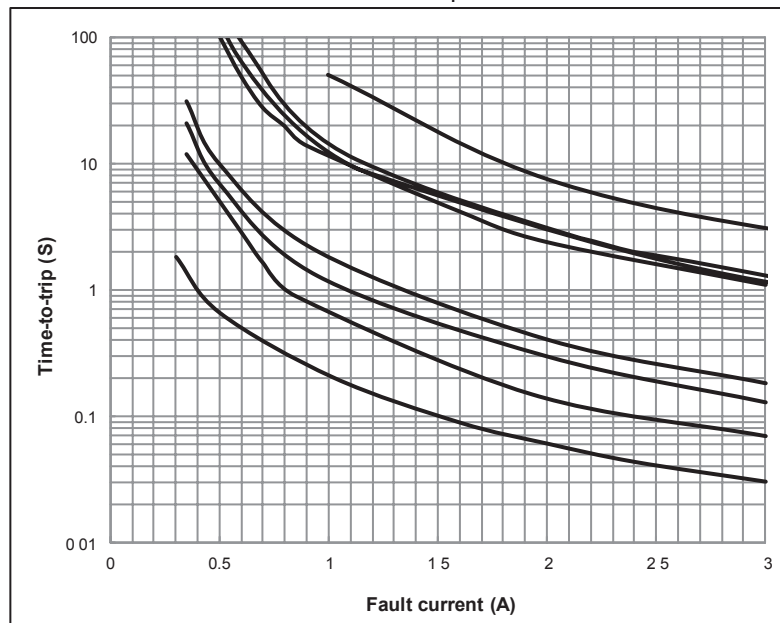

Part Numbering System

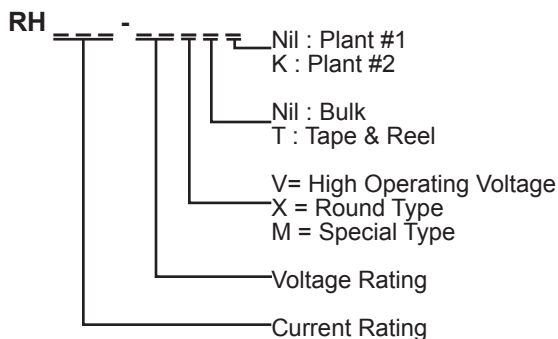

Part Marking System

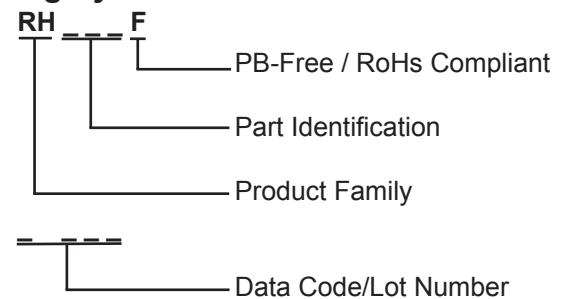



RH Series

Radial Leaded PTC

Standard Package

P/N	Pcs /Bag	Reel/Tape
RH080-250V	300	1500
RH110-250V	300	1500
RH120-250V	300	1500
RH145-250V	300	1500
RH180-250X	200	1500
RH150-600M	100	1200
RH160-600M	100	1200
RH160-600V	100	600
RH200-600V	100	1200
RH250-600V	100	1200
RH400-600	100	600

1- Operation beyond the specified maximum ratings or improper use may result in damage and possible electrical arcing and/or flame.

2 -PPTC device are intended for occasional overcurrent protection. Application for repeated overcurrent condition and/or prolonged trip are not anticipated.

3- Avoid contact of PPTC device with chemical solvent. Prolonged contact will damage the device performance.