

## FEATURES

- ❑ Single power supply operation (3.3V to 5.0V) or dual power supply operation ( $\pm 1.65$  to  $\pm 2.5V$ )
- ❑ Radiation performance
  - Total dose:  $>1$  Mrad(Si); Dose rate = 50-300 rad(Si)/s
  - ELDRS Immune
  - SEL Immune  $>100$  MeV-cm<sup>2</sup>/mg
  - Neutron Displacement Damage  $>10^{14}$  neutrons/cm<sup>2</sup>
- ❑ Rail-to-Rail input and output range
- ❑ Enable pin to Enable/Disable amplifiers in pairs.
- ❑ Short Circuit Tolerant
- ❑ Full military temperature range
- ❑ Designed for aerospace and high reliability space applications
- ❑ Packaging – Hermetic ceramic SOIC
  - 16-pin, .417"L x .300"W x .120"Ht
  - Weight - 0.8 grams max
- ❑ **Radiation Hardness Assurance Plan: DLA Certified to MIL-PRF-38534, Appendix G.**

## GENERAL DESCRIPTION

The RHD5901 is a radiation hardened, single supply, quad operational amplifier with enable in a 16-pin SOIC package. The RHD5901 design uses specific circuit topology and layout methods to mitigate total ionizing dose effects and single event latchup. These characteristics make the RHD5901 especially suited for the harsh environment encountered in Deep Space missions. It is guaranteed operational from -55°C to +125°C. Available screened in accordance with MIL-PRF-38534 Class K, the RHD5901 is ideal for demanding military and space applications.

## ORGANIZATION AND APPLICATION

The RHD5901 amplifiers are capable of rail-to-rail input and outputs. Performance characteristics listed are for general purpose operational 5V CMOS amplifier applications. The amplifiers will drive substantial resistive or capacitive loads and are unity gain stable under normal conditions. Resistive loads in the low kohm range can be handled without gain derating and capacitive loads of several nF can be tolerated. CMOS device drive has a negative temperature coefficient and the devices are therefore inherently tolerant to momentary shorts, although on chip thermal shutdown is not provided. All inputs and outputs are diode protected.

The devices will not latch with SEU events to above 100 MeV-cm<sup>2</sup>/mg. Total dose degradation is minimal to above 1 Mrad(Si). Displacement damage environments to neutron fluence equivalents in the mid 10<sup>14</sup> neutrons per cm<sup>2</sup> range are readily tolerated. There is no sensitivity to low-dose rate (ELDRS) effects. SEU effects are application dependent.

The RHD5901 is configured with enable/disable control. Pairs of amplifiers are put in a power-down condition with their outputs in a high impedance state. Several useful operational amplifier configurations are supported where more than one amplifier can feed an output with others disabled.

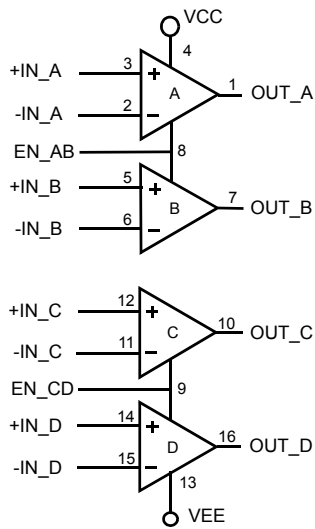

**FIGURE 1: BLOCK DIAGRAM**

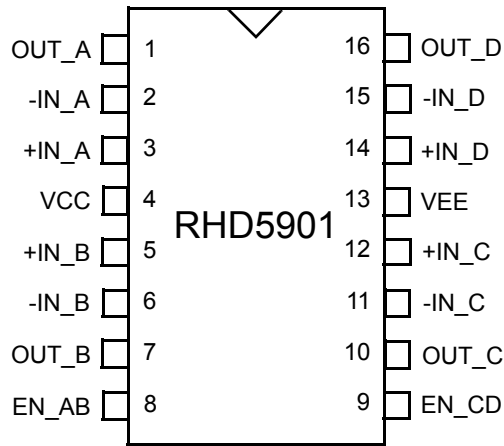

**16-Pin SOIC**

**FIGURE 2: PACKAGE PIN-OUT**

Notes:

1. Package and lid are electrically isolated from signal pads.
2. EN\_AB enables amplifiers A & B. EN\_CD enables amplifiers C & D.

## ABSOLUTE MAXIMUM RATINGS

Parameter	Range	Units
Case Operating Temperature Range	-55 to +125	°C
Storage Temperature Range	-65 to +150	°C
Junction Temperature	+150	°C
Supply Voltage V <sub>CC</sub> - V <sub>EE</sub>	+7.0	V
Input Voltage	V <sub>CC</sub> +0.4 V <sub>EE</sub> -0.4	V
Lead Temperature (soldering, 10 seconds)	300	°C
Thermal Resistance, Junction to Case, $\theta_{jc}$	7	°C/W
Power @ 25°C	200	mW

NOTICE: Stresses above those listed under "Absolute Maximum Ratings" may cause permanent damage to the device. These are stress rating only; functional operation beyond the "Operation Conditions" is not recommended and extended exposure beyond the "Operation Conditions" may affect device reliability.

## RECOMMENDED OPERATING CONDITIONS

Symbol	Parameter	Typical	Units
+V <sub>CC</sub>	Power Supply Voltage	3.3 to 5.0	V
V <sub>CM</sub>	Input Common Mode Range	V <sub>CC</sub> to V <sub>EE</sub>	V

## ELECTRICAL PERFORMANCE CHARACTERISTICS

(T<sub>C</sub> = -55°C TO +125°C, +V<sub>CC</sub> = +5.0V -- UNLESS OTHERWISE SPECIFIED)

Parameter	Symbol	Conditions	Min	Typ	Max	Units
Quiescent Supply Current <u>1/</u>	I <sub>CCQ</sub>	EN = 1, No Load		4.7	5.5	mA
		EN = 0, <u>2/</u>			300	nA
Input Offset Voltage <u>1/</u>	V <sub>OS</sub>		-3	0.80	3	mV
Input Offset Current <u>1/</u>	I <sub>OS</sub>		-100	10	100	pA
Input Bias Current	I <sub>B</sub>	T <sub>C</sub> = +25°C, -55°C <u>1/</u>	-100	10	100	pA
		T <sub>C</sub> = +125°C	-1000	100	1000	
Common Mode Rejection Ratio	CMRR		70	90		dB
Power Supply Rejection Ratio	PSRR		70	90		dB
Output Voltage High	V <sub>OH</sub>	R <sub>OUT</sub> = 3.6 Kohms to GND	4.9			V
Output Voltage Low	V <sub>OL</sub>	R <sub>OUT</sub> = 3.6 Kohms to V <sub>CC</sub>			0.1	V
Short Circuit Output Current <u>2/</u>	I <sub>O(SINK)</sub>	V <sub>OUT</sub> to V <sub>CC</sub>	-30		-75	mA
	I <sub>O(SOURCE)</sub>	V <sub>OUT</sub> to V <sub>EE</sub>	45		55	mA
Slew Rate <u>1/</u>	SR	R <sub>L</sub> = 8K, Gain = 1	2.0	3.3		V/μS

## ELECTRICAL PERFORMANCE CHARACTERISTICS (Continued)

(Tc = -55°C TO +125°C, +Vcc = +5.0V -- UNLESS OTHERWISE SPECIFIED)

Parameter	Symbol	Conditions	Min	Typ	Max	Units
Open Loop Gain <u>1/</u>	AOL	No Load	90	100		dB
Unity Gain Bandwidth <u>1/</u>	UGBW	RL = 10K	4	6.5		MHz
Input Voltage - Enable (EN_AB, EN_CD)	VHI	High (Enabled)	3.5			V
	VLO	Low (Disabled)			1.5	V
Input Current - Enable (EN_AB, EN_CD)	IEN				10	nA
Channel Separation <u>2/</u>		RL = 2K, f = 1.0KHz	84			dB
Input-Referred Voltage Noise <u>2/</u>	e <sub>n</sub>	F = 5 kHz		15		nV/ $\sqrt{\text{Hz}}$
Phase Margin <u>2/</u>	$\Phi_m$	Tc = +25°C, No load	30			Deg

Notes:

1/ Specification derated to reflect Total Dose exposure to 1 Mrad(Si) @ +25°C.

2/ Not tested. Shall be guaranteed by design, characterization, or correlation to other test parameters.

## SWITCHING CHARACTERISTICS

(Tc = -55°C TO +125°C, +Vcc = +5.0V -- UNLESS OTHERWISE SPECIFIED)

Parameter	Symbol	Conditions	Min	Max	Units
Output Delay (Enabled) <u>2/</u>	t <sub>ONEN</sub>			500	ns
Output Delay (Disabled) <u>2/</u>	t <sub>OFFEN</sub>			100	ns

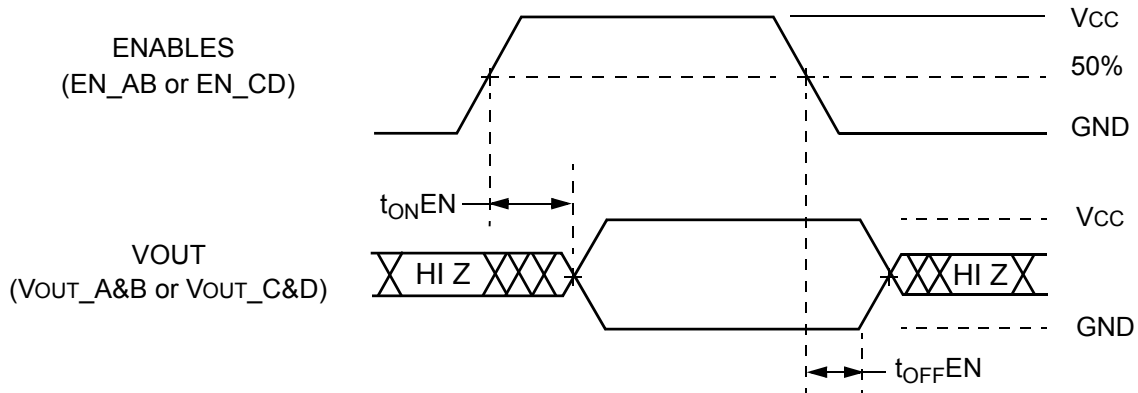

**FIGURE 3: RHD5901 SWITCHING DIAGRAM**

# RHD5901 QUAD OPERATIONAL AMPLIFIER APPLICATION NOTES

## APPLICATION NOTE 1: DUAL POWER SUPPLY AMPLIFIER

### Inverting Amplifier

$$V_{OUT} = -V_{IN} \left( \frac{R_2}{R_1} \right)$$

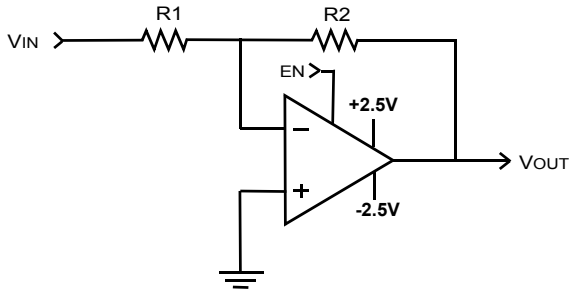

### Non Inverting Amplifier

$$V_{OUT} = V_{IN} \left( 1 + \frac{R_2}{R_1} \right)$$

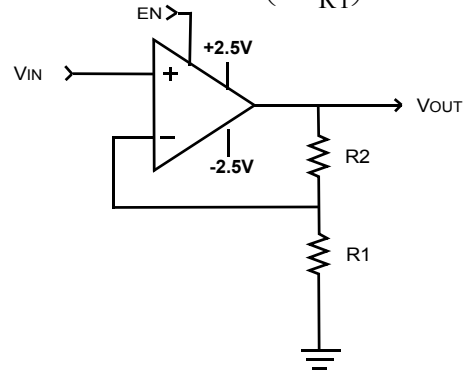

## APPLICATION NOTE 2: SINGLE POWER SUPPLY AMPLIFIER

### Inverting Amplifier

$$V_{OUT} = -V_{IN} \left( \frac{R_2}{R_1} \right)$$

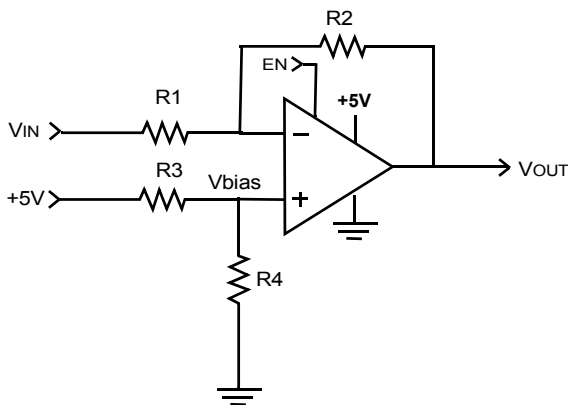

### Non Inverting Amplifier

$$V_{OUT} = V_{IN} \left( 1 + \frac{R_2}{R_1} \right)$$

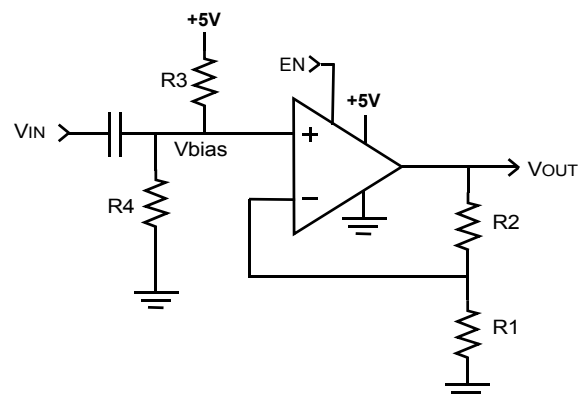

Note: For  $V_{OUT}$  DC @ mid range of common mode voltage range,  $V_{BIAS} = 2.5 / (1 + R_2/R_1)$ ,  $V_{BIAS} = +5 * R_4 / (R_3 + R_4)$

### APPLICATION NOTE 3: DIFFERENTIAL INPUT AMPLIFIER

#### Differential Input Amplifier

$$V_{OUT} = \left( V_2 \left( \frac{R_4}{R_3 + R_4} \right) \left( 1 + \frac{R_2}{R_1} \right) \right) - \left( V_1 \frac{R_2}{R_1} \right)$$

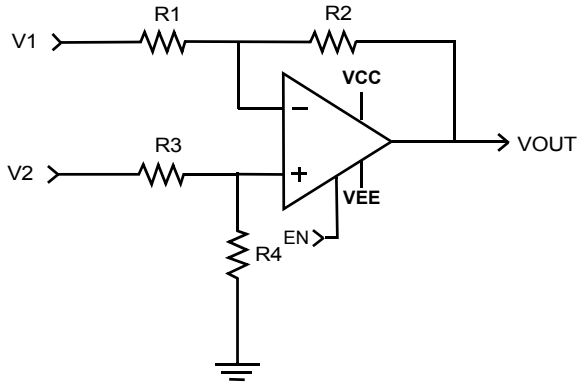

### APPLICATION NOTE 4: MULTIPLE AMPLIFIERS

#### Multiple Amplifiers - Selectable Output

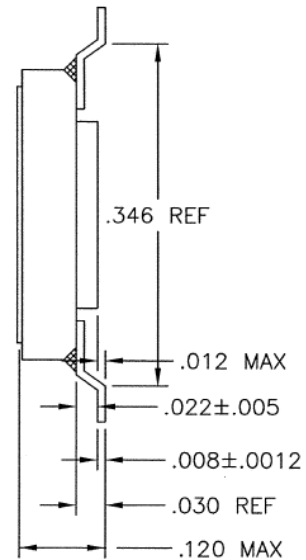
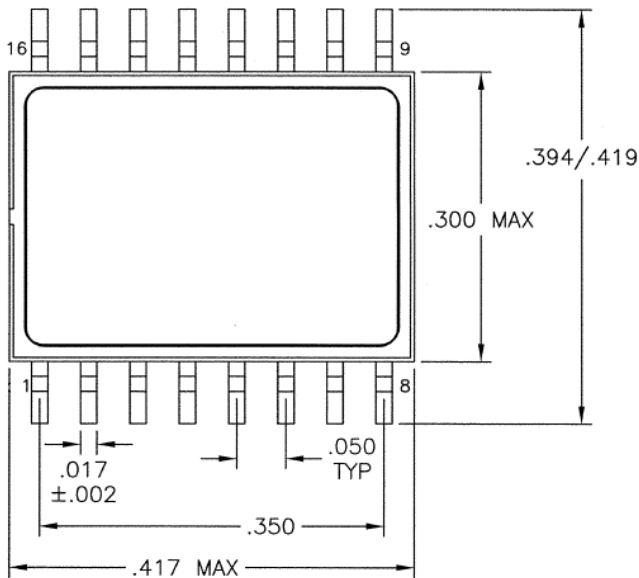
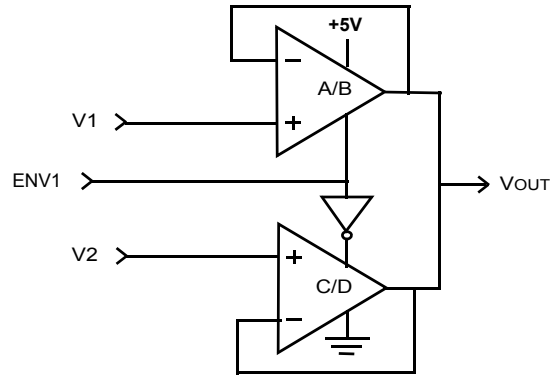

Note: Package and lid are electrically isolated from signal pads.

FIGURE 4: PACKAGE OUTLINE

## ORDERING INFORMATION

Model	DLA SMD #	Screening	Package
RHD5901-7	-	Commercial Flow, +25°C testing only	16-pin SOIC Package
RHD5901-S	-	Military Temperature, -55°C to +125°C Screened in accordance with the individual Test Methods of MIL-STD-883 for Space Applications	
RHD5901-201-1S	5962-1024102KXC	In accordance with DLA SMD	
RHD5901-201-2S	5962-1024102KXA		
RHD5901-901-1S	5962H1024102KXC	In accordance with DLA Certified RHA Program Plan to RHA Level "H", 1 Mrad(Si)	
RHD5901-901-2S	5962H1024102KXA		

## REVISION HISTORY

Date	Revision	Change Description
03/28/2016	G	Import into Cobham format



## *Datasheet Definition*

**Advanced Datasheet - Product In Development**

**Preliminary Datasheet - Shipping Prototype**

**Datasheet - Shipping QML & Reduced Hi-Rel**

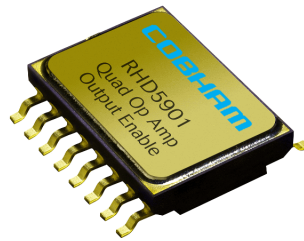

### **EXPORT CONTROL:**

*This product is controlled for export under the Export Administration Regulations (EAR), 15 CFR Parts 730-774. A license from the Department of Commerce may be required prior to the export of this product from the United States.*

**Cobham Semiconductor Solutions**  
35 S. Service Road  
Plainview, NY 11803

**E: [info-ams@cobham.com](mailto:info-ams@cobham.com)**  
**T: 800 645 8862**

**COBHAM**

Aeroflex Plainview Inc., DBA Cobham Semiconductor Solutions, reserves the right to make changes to any products and services described herein at any time without notice. Consult Aeroflex or an authorized sales representative to verify that the information in this data sheet is current before using this product. Aeroflex does not assume any responsibility or liability arising out of the application or use of any product or service described herein, except as expressly agreed to in writing by Aeroflex; nor does the purchase, lease, or use of a product or service from Aeroflex convey a license under any patent rights, copyrights, trademark rights, or any other of the intellectual rights of Aeroflex or of third parties.