

The most important thing we build is trust

FEATURES

- ❑ Radiation performance
 - Total dose: >1 Mrad(Si), Dose rate = 50-300 rad(Si)/s
 - ELDRS Immune
 - SEL Immune: >100 MeV-cm²/mg
 - Neutron Displacement Damage: >10¹⁴ neutrons/cm²
- ❑ 11-Bit DAC
- ❑ Buffered Output
- ❑ Single power supply operation at +3.3V to +5V
- ❑ Low Power
- ❑ CMOS/TTL inputs
- ❑ Full military temperature range
- ❑ Designed for aerospace and high reliability space applications
- ❑ Packaging – Hermetic ceramic SOIC
 - 16 leads, 0.417"L x 0.300"W x 0.120"Ht
 - Typical Weight 0.8 grams

- ❑ **Radiation Hardness Assurance Plan: DLA Certified to MIL-PRF-38534, Appendix G.**

GENERAL DESCRIPTION

The 11-Bit DAC is a standard CMOS R/2R Kelvin resistor network with a buffered output. The digital inputs, D10(MSB) through D00(LSB), are buffered to drive single-pole double-throw CMOS switches to apply either the PREF or NREF signals to the 2R legs of the resistor network.

PREF and NREF inputs can be any static or dynamic voltage within the power supply range. The nominal values for R and 2R are 5K and 10K respectively. The characteristic impedance of the resistor network is approximately 5K.

The voltage-output configuration of the integrated circuit can be thought of as a digitally controlled voltage with a value of PREF-NREF with a high output impedance. The output will swing rail-to-rail if unloaded. Applications include digital potentiometers, programmable voltage sources and a large variety of other circuits that can be found in many industry references.

ABSOLUTE MAXIMUM RATINGS

Parameter	Range	Units
Case Operating Temperature Range	-55 to +125	°C
Storage Temperature Range	-65 to +150	°C
Junction Temperature	+150	°C
Lead Temperature (soldering, 10 seconds)	300	°C
Thermal Resistance, Junction to Case, θ_{jc}	7	°C/W
Supply Voltage +V _{CC}	+7.0	V
PREF relative to NREF	+6.0	V
Digital Input Voltage	V _{CC} +0.4 GND -0.4	V
Power @25°C	50	mW

NOTICE: Stresses above those listed under "Absolute Maximum Ratings" may cause permanent damage to the device. These are stress rating only; functional operation beyond the "Operation Conditions" is not recommended and extended exposure beyond the "Operation Conditions" may affect device reliability.

RECOMMENDED OPERATING CONDITIONS

Symbol	Parameter	Typical	Units
+V _{CC}	Power Supply Voltage	3.3 to 5.0	V

ELECTRICAL PERFORMANCE CHARACTERISTICS (T_c = -55°C to +125°C, +V_{CC} = +5.0V -- Unless otherwise specified)

Parameter	Symbol	Conditions	Min	Max	Units
Supply Current ^{1/}	I _{CC}	Toggle inputs, V _{CC} , GND		5	mA
Quiescent current ^{1/}	I _{CCQ}	All inputs = GND		5	mA
Relative Accuracy ^{1/}	RA	PREF = 4.9 V, NREF = 0.1 V		0.25	% of FSR
Gain Error ^{1/}	AE	PREF = 4.9 V, NREF = 0.1 V		0.55	% of FSR
Offset Error ^{1/}	OFF ₂	PREF = 4.9 V, NREF = 0.1 V		0.25	% of FSR
Differential Nonlinearity ^{1/ 2/}	DNL	PREF = 4.9 V, NREF = 0.1 V		0.25	% of FSR
Output Settling Time	T _D	All inputs = Gnd to V _{CC} , PREF = 4.9 V, NREF = 0.1 V, Output = 1/2 LSB of Nominal		5	us
PREF Input Z ^{2/}	Z _P		3	7	KΩ
NREF Input Z ^{2/}	Z _R		3	7	KΩ
Input Hi Voltage	V _{IH}	PREF = 4.9 V, NREF = 0.1 V	3.5		V
Input Lo Voltage	V _{IL}	PREF = 4.9 V, NREF = 0.1 V		1.5	V
Input High Leakage ^{1/ 3/}	I _{IH}	Input under test = GND		1	nA
Input Low Leakage ^{1/ 3/}	I _{IL}	Input under test = V _{CC}		1	nA
Resolution ^{2/}	N		11		Bits

Note: ^{1/} Specification derated to reflect Total Dose exposure to 1 Mrad(Si) @ +25°C.

^{2/} Not Tested. Shall be guaranteed by design, characterization, or correlation to other test parameters.

^{3/} These parameters for T_c = -55°C are guaranteed by design, characterization, or correlation to other test parameters.

Package Pin #s	Signal	Definitions
1	PREF	Positive Analog Voltage Reference.
2	NREF	Negative Analog Voltage Reference
3	GND	- Voltage Supply
4	D10	Digital Bit 10 (MSB)
5	D09	Digital Bit 09
6	D08	Digital Bit 08
7	D07	Digital Bit 07
8	D06	Digital Bit 06
9	D05	Digital Bit 05
10	D04	Digital Bit 04
11	D03	Digital Bit 03
12	D02	Digital Bit 02
13	D01	Digital Bit 01
14	D00	Digital Bit 00 (LSB)
15	VCC	+ Voltage Supply
16	AOUT	Analog Output (Buffered)

FIGURE 1: PINOUT DESCRIPTIONS

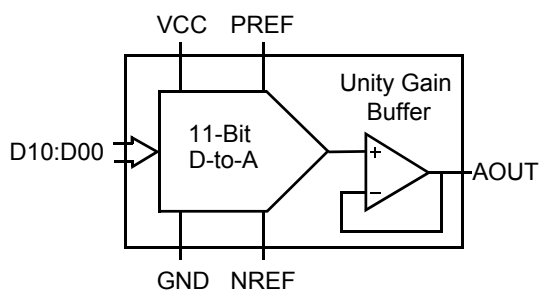

FIGURE 2: SCHEMATIC SYMBOL

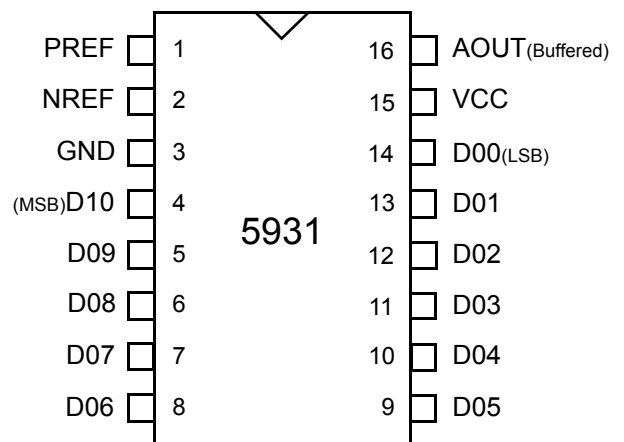
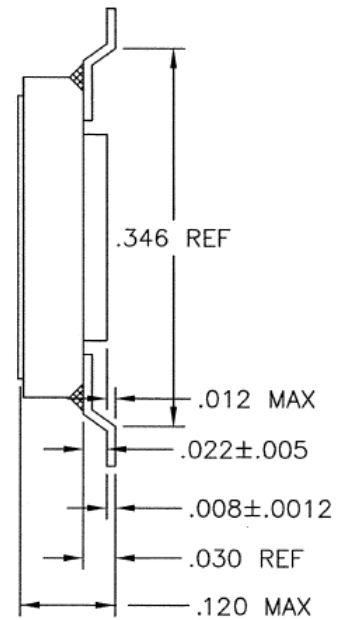
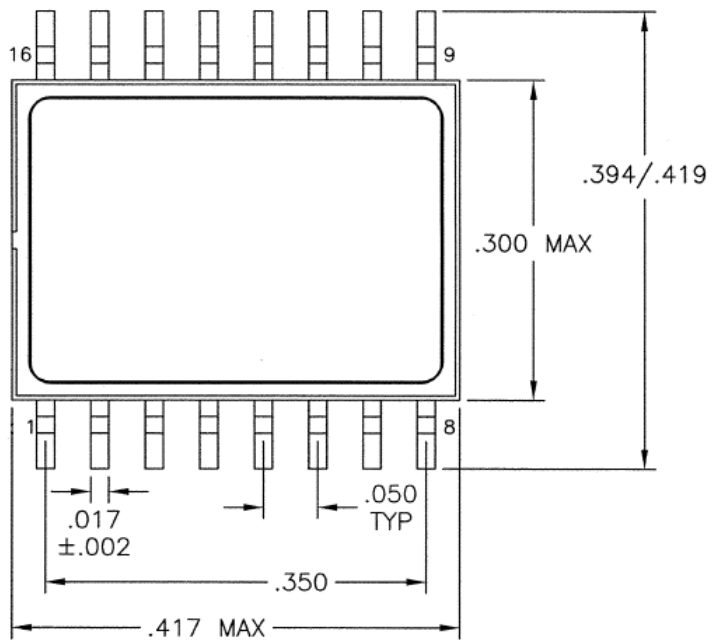

FIGURE 3: PACKAGE PINOUT



Note: Package and lid are electrically isolated from signal pads.

FIGURE 4: SOIC PACKAGE OUTLINE

ORDERING INFORMATION

Model	DLA SMD #	Screening	Package
RHD5931-7	-	Commercial Flow, +25°C testing only	16-pin SOIC Package
RHD5931-S	-	Military Temperature, -55°C to +125°C Screened in accordance with the individual Test Methods of MIL-STD-883 for Space Applications	
RHD5931-201-1S	5962-1120802KXC	In accordance with DLA SMD	
RHD5931-201-2S	5962-1120802KXA		
RHD5931-901-1S	5962H1120802KXC	In accordance with DLA Certified RHA Program Plan to RHA Level "H", 1 Mrad(Si)	
RHD5931-901-2S	5962H1120802KXA		

REVISION HISTORY

Date	Revision	Change Description
03/29/2016	E	Import into Cobham format

Datasheet Definition

Advanced Datasheet - Product In Development

Preliminary Datasheet - Shipping Prototype

Datasheet - Shipping QML & Reduced Hi-Rel

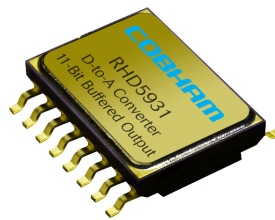

EXPORT CONTROL:

This product is controlled for export under the Export Administration Regulations (EAR), 15 CFR Parts 730-774. A license from the Department of Commerce may be required prior to the export of this product from the United States.

Cobham Semiconductor Solutions
35 S. Service Road
Plainview, NY 11803

E: info-ams@cobham.com
T: 800 645 8862

COBHAM

Aeroflex Plainview Inc., DBA Cobham Semiconductor Solutions, reserves the right to make changes to any products and services described herein at any time without notice. Consult Aeroflex or an authorized sales representative to verify that the information in this data sheet is current before using this product. Aeroflex does not assume any responsibility or liability arising out of the application or use of any product or service described herein, except as expressly agreed to in writing by Aeroflex; nor does the purchase, lease, or use of a product or service from Aeroflex convey a license under any patent rights, copyrights, trademark rights, or any other of the intellectual rights of Aeroflex or of third parties.