

GLASS PASSIVATED SILICON RECTIFIER

VOLTAGE RANGE 50 to 800 Volts CURRENT 16 Amperes

FEATURES

- * Low power loss, high efficiency
- * Low forward voltage drop
- * Low thermal resistance
- * High current capability
- * High surge capability
- * High reliability

MECHANICAL DATA

- * Case: D2-PAK molded plastic
- * Epoxy: Device has UL flammability classification 94V-O
- * Lead: MIL-STD-202E method 208C guaranteed
- * Mounting position: Any
- * Weight: 1.4 grams
- * Polarity: As marked

MAXIMUM RATINGS AND ELECTRICAL CHARACTERISTICS

Ratings at 25 °C ambient temperature unless otherwise specified.
Single phase, half wave, 60 Hz, resistive or inductive load.
For capacitive load, derate current by 20%.

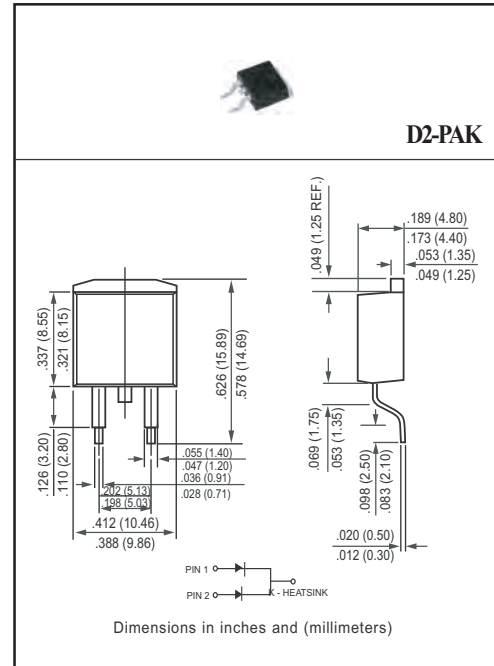

MAXIMUM RATINGS (At TA = 25°C unless otherwise noted)

RATINGS	SYMBOL	RL1601CS	RL1602CS	RL1603CS	RL1604CS	RL1605CS	RL1606CS	UNITS
Maximum Recurrent Peak Reverse Voltage	VRRM	50	100	200	400	600	800	Volts
Maximum RMS Voltage	VRMS	35	70	140	280	420	560	Volts
Maximum DC Blocking Voltage	VDC	50	100	200	400	600	800	Volts
Maximum Average Forward Rectified Current TC = 100°C (Note 1)	Io	16.0						Amps
Peak Forward Surge Current, 8.3 ms single half sine-wave superimposed on rated load (JEDEC method)	IFSM	150						Amps
Typical Current Square Time	I ² T	93.4						A ² S
Typical Thermal Resistance	RθJC	3.0						°C/W
Typical Junction Capacitance (Note 2)	Cj	40						pF
Operating and Storage Temperature Range	TJ, TSTG	-55 to + 150						°C

ELECTRICAL CHARACTERISTICS (At TA = 25°C unless otherwise noted)

CHARACTERISTICS	SYMBOL	RL1601CS	RL1602CS	RL1603CS	RL1604CS	RL1605CS	RL1606CS	UNITS
Maximum Instantaneous Forward Voltage at 8.0A DC	VF	1.0						Volts
Maximum DC Reverse Current at Rated DC Blocking Voltage	@Tc = 25°C	2						uAmps
	@Tc = 100°C	50						

- NOTES : 1. Case Temperature Measured at Metal Tab.
2. Measured at 1 MHz and applied reverse voltage of 4.0 volts.
3. Suffix " A " = Common Anode.

RATING AND CHARACTERISTIC CURVES(RL1601CS THRU RL1606CS)

FIG. 1 - TYPICAL FORWARD CURRENT DERATING CURVE

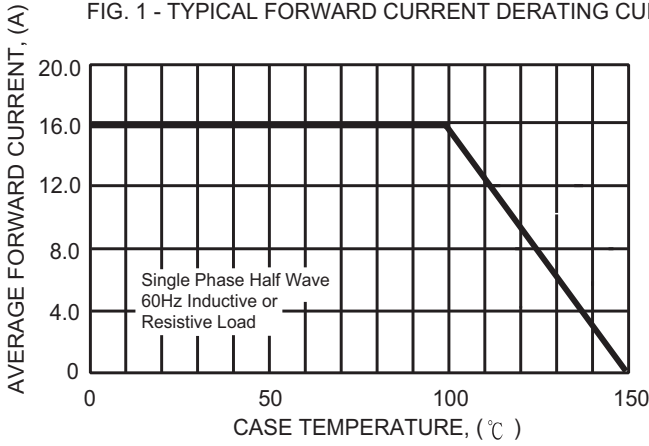

FIG. 2 - TYPICAL REVERSE CHARACTERISTICS

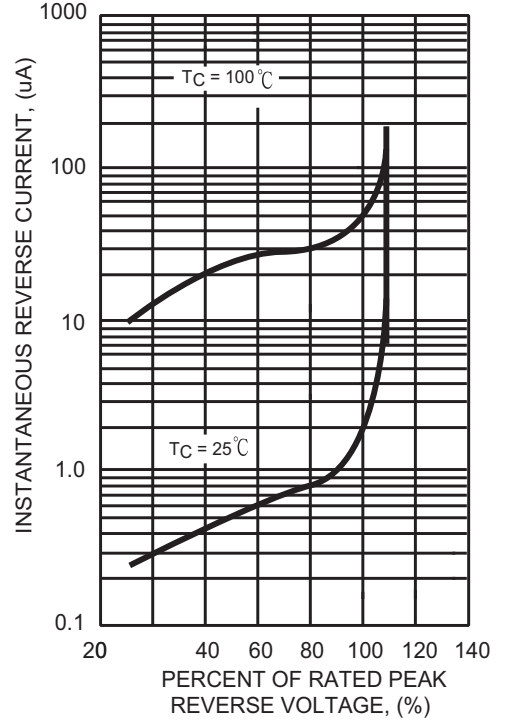

FIG. 3 - MAXIMUM NON-REPETITIVE FORWARD SURGE CURRENT

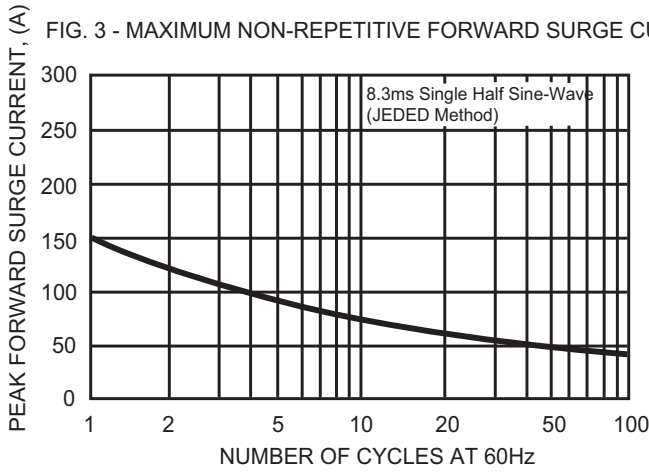

FIG. 4 - TYPICAL JUNCTION CAPACITANCE

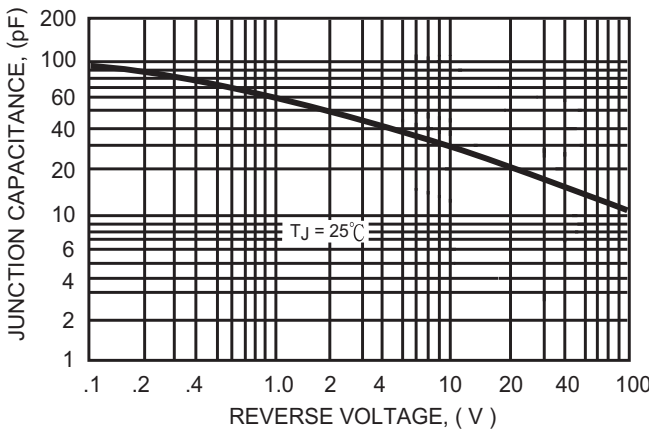
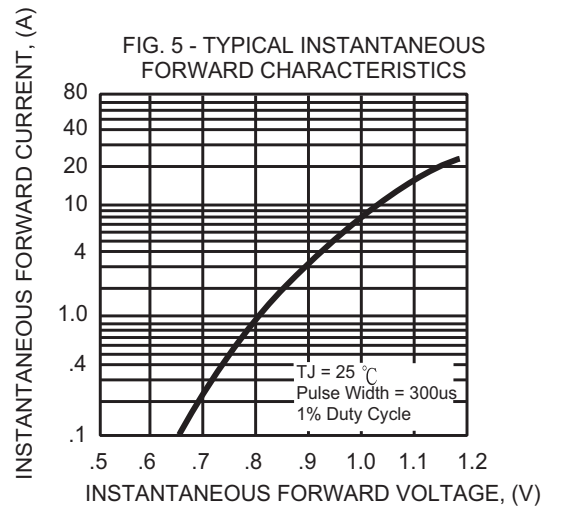

FIG. 5 - TYPICAL INSTANTANEOUS FORWARD CHARACTERISTICS



PACKAGING OF DIODE AND BRIDGE RECTIFIERS

BULK PACK

PACKAGE	PACKING CODE	EA PER BOX	INNER BOX SIZE (mm)	CARTON SIZE (mm)	EA PER CARTON	GROSS WEIGHT(Kg)
A-405	-B	1,000	194*84*21	415*220*255	50,000	15.64
BR-3/-6	-B	200	206*208*55	450*220*255	1,600	6.00 / 6.80
BR-8/-10	-B	200	236*236*50	497*251*282	2,000	12.24
BR-15/-25/-35(W)	-B	50	206*208*57	450*220*255	400	12.50 (14.40)
DO-15	-B	500	194*84*21	415*220*255	25,000	12.74
DO-201	-B	500	300*73*40	347*320*271	12,000	15.90
DO-41	-B	1,000	194*75*21	415*220*255	50,000	16.2
HVM	-B	200	165*214*52	353*226*290	2,000	---
HVP	-B	40	236*236*40	502*251*145	240	8.80
MB-15/-25/-35(W)	-B	50	206*208*57	450*220*255	400	13.60 (14.30)
MP-15/-25/-35(W)	-B	50	206*208*57	450*220*255	400	7.7 (8.26)
R-1/-3	-B	1000 / 500	192*75*21	415*220*255	50,000 / 25,000	11.74 / 16.17
R-6/R-7	-B	200	300*73*40	347*320*271	4,800	12.93 / 14.57
RB-15	-B	1,000	165*252*59	347*320*271	10,000	11.6
RBU	-B	450	240*239*35	502*251*126	2,700	13.00
RC-2	-B	600	165*252*59	347*320*271	6,000	9.4
RS-1	-B	600	240*239*35	497*255*162	4,800	9.264
RS-2L	-B	400	210*160*52	502*251*126	2,400	8.59
RS-4L	-B	300	230*162*52	502*251*126	1,800	11.3
RS-6/-8	-B	200	236*236*34	497*255*162	1,600	13.6 / 14.5
RS-1M	-B	600	240*239*35	497*255*162	4,800	8.62
RS-2M	-B	600	236*236*40	502*251*145	3,600	10.28
RS-4M/-10M	-B	600	236*236*40	497*251*100	2,400	11.09
RS-6/8/15/20/25M	-B	300	230*190*46	410*243*157	1,800	13.37
WOM	-B	600	165*252*59	347*320*271	6,000	11.0

TUBE PACK

PACKAGE	PACKING CODE	EA PER BOX	INNER BOX SIZE (mm)	CARTON SIZE (mm)	EA PER CARTON	WEIGHT(Kg)
BDB	-C	2,000	450*140*84	464*305*283	12,000	14.18
D2PAK	-C	2,000	550*140*92	572*308*120	4,000	10.20
DB-1	-C	2,500	450*140*84	464*305*283	15,000	14.30
DB-LS	-C	4,000	450*140*84	464*305*283	24,000	16.45
DB-S	-C	4,000	450*140*84	464*305*283	24,000	18.44
RBU	-C	1,000	490*135*110	510*293*131	2,000	13.62
RS-1M/-2M	-C	1,350	540*118*118	560*259*144	2,700	12.03
RS-4M/-10M	-C	900	540*118*118	560*259*144	1,800	12.82
RS-6/8/15/20/25M	-C	600	490*135*110	510*293*131	1,200	13.12
(I)TO-220/TO-220(A)	-C	2,000	550*140*92	572*308*120	4,000	11.80
TO-247	-C	900	550*140*92	572*308*120	1,800	7.60



Attachment information about RL160XC

1. Internal Circuit



2. Marking on the body

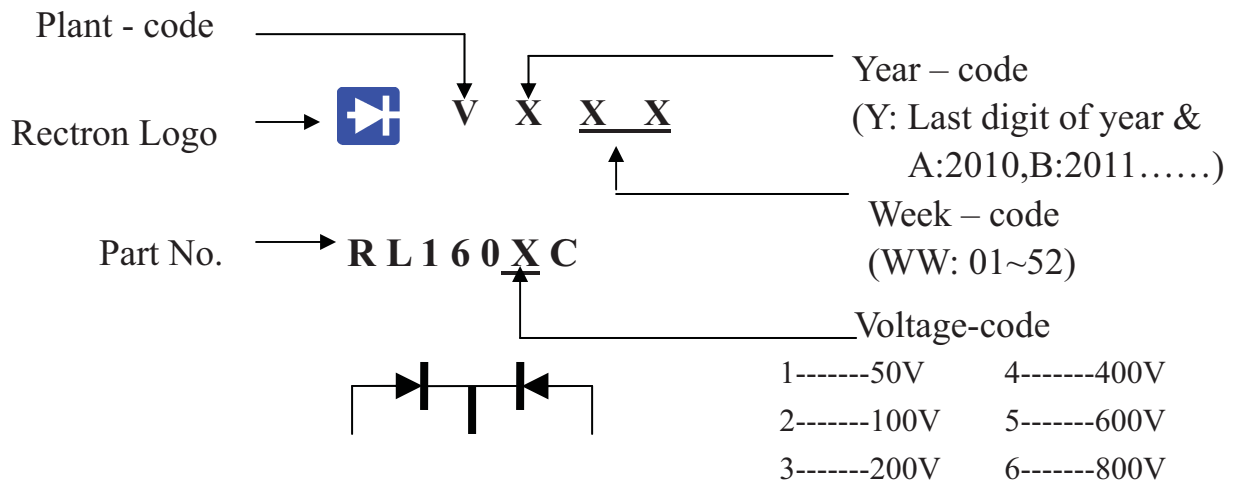

3. Items marked on the inner box and carton

3.1 On the box (for -C)

CUSTOMER
TYPE
LOT NO.
QUANTITY
Q.A.
DATE

3.2 On the carton

CUSTOMER
TYPE
QUANTITY
LOT NO.
REMARK

DISCLAIMER NOTICE

Rectron Inc reserves the right to make changes without notice to any product specification herein, to make corrections, modifications, enhancements or other changes. Rectron Inc or anyone on its behalf assumes no responsibility or liability for any errors or inaccuracies. Data sheet specifications and its information contained are intended to provide a product description only. "Typical" parameters which may be included on RECTRON data sheets and/ or specifications can and do vary in different applications and actual performance may vary over time. Rectron Inc does not assume any liability arising out of the application or use of any product or circuit.

Rectron products are not designed, intended or authorized for use in medical, life-saving implant or other applications intended for life-sustaining or other related applications where a failure or malfunction of component or circuitry may directly or indirectly cause injury or threaten a life without expressed written approval of Rectron Inc. Customers using or selling Rectron components for use in such applications do so at their own risk and shall agree to fully indemnify Rectron Inc and its subsidiaries harmless against all claims, damages and expenditures.