



RLT850-50MGS

- Infrared Laser Diode
- 850 nm, 50 mW CW
- Single Mode
- 5.6 mm TO-Can, Flat Window
- Built-in Monitor PD



Description



RLT850-50MGS is a single mode Laser Diode emitting at typical 850 nm with rated output power of 50 mW CW at room temperature. The 5.6 mm TO package includes a cap and flat window, and contains a built-in **monitor PD**.

Maximum Ratings ($T_{CASE}=25^{\circ}C$)

Parameter	Symbol	Values		Unit
		Min.	Max.	
Forward Current	I_F			mA
Reverse Voltage	V_F		3.5	V
Operating Temperature	T_{CASE}	- 10	+ 40	$^{\circ}C$
Storage Temperature	T_{STG}	- 15	+ 85	$^{\circ}C$
Lead Solder Temperature *2	T_{SLD}		+ 260	$^{\circ}C$

*1 must be completed within 5 seconds

Electro-Optical Characteristics ($T_{CASE}=25^{\circ}C$)

Parameter	Symbol	Values			Unit
		Min.	Typ.	Max.	
Peak Wavelength	λ_P	830	840	850	nm
Half Width	$\Delta\lambda$		2.0		nm
Optical Output Power (CW Mode)	P_O		50		mW
Laser Beam Mode		Single Mode			
Emitter Size					μm
Threshold Current	I_{TH}		28	35	mA
Forward Current	I_{OP}		85	110	mA
Forward Voltage	V_{OP}	1.5	1.8	2.1	V
Slope Efficiency	η	0.7	0.9		mW/mA
Beam Divergence	$\theta_{ }$	10	15	20	$^{\circ}$
Beam Divergence	θ_{\perp}	22	30	38	$^{\circ}$
Monitor Current	I_M		0.1		mA
PD Reverse Voltage			30		V



Outline Dimensions

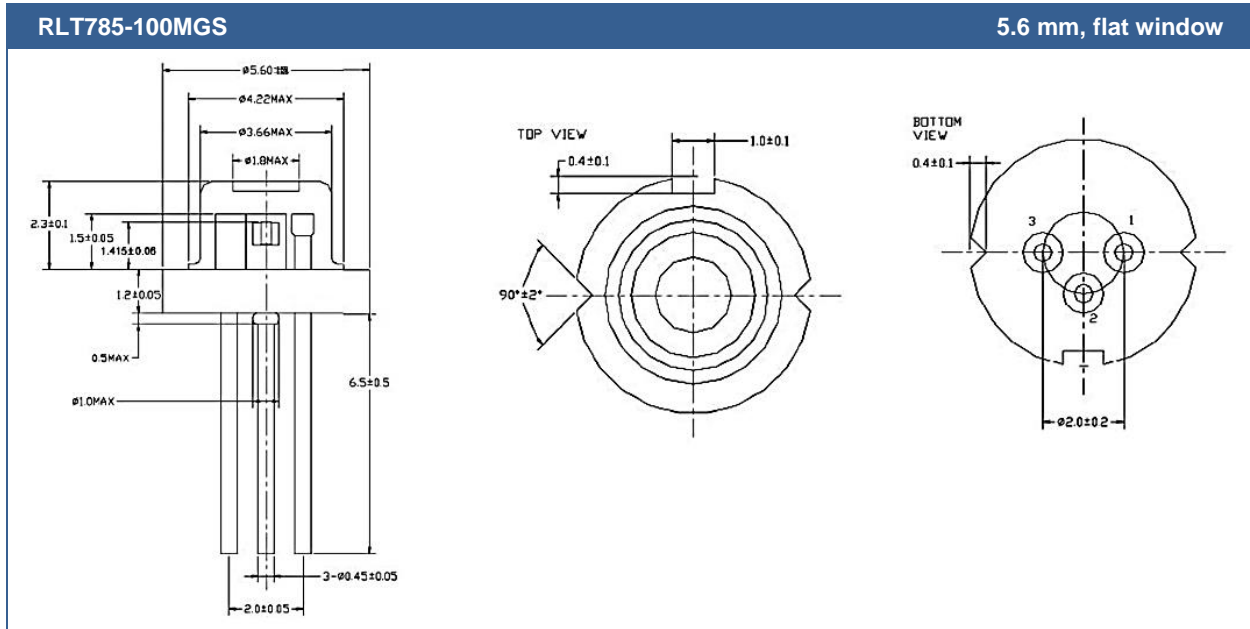

All Dimensions in mm

Electrical Connection

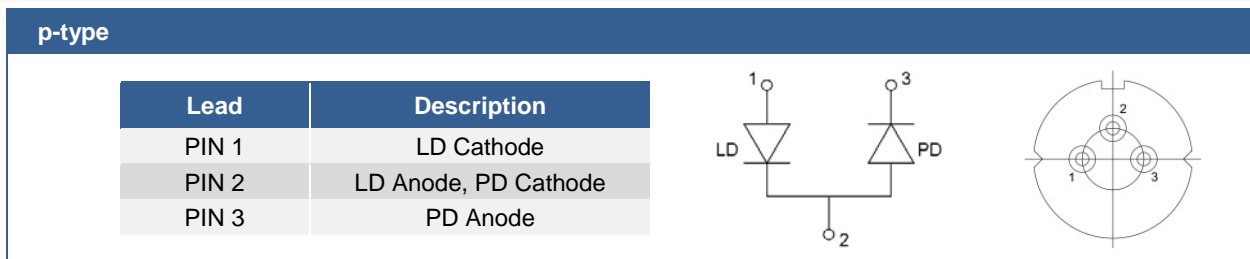



Precautions

ESD Caution:

Always do handle laser diodes with extreme caution to prevent electrostatic discharge, the primary cause of unexpected diode failure. ESD failures can be prevented by always wearing wrist straps, only using a grounding workplace, and following strict anti-static guidelines when handling the laser diode.



Safety Advice:

This laser diode emits highly concentrated infrared light which can be **hazardous to the human eye and skin**. This diode is classified as **CLASS 3 laser product** according to **IEC 60825-1** and **21 CFR Part 1040.10 Safety Standards**.

Operating Considerations:

Operating the laser diode outside of its maximum ratings may cause failure or a safety hazard. The diode may be damaged by excessive drive currents or switching transients. If the diode is operated using a power supply, it is strongly recommended to connect the diode with the output voltage set to zero. The voltage should then be increased slowly and with great caution, while at the same time carefully monitoring the laser diodes output power and drive current. The laser diode will show accelerated degradation with increased temperature, and it is advised to keep the case temperature low therefor, by means of heat sinking the device.

© All Rights Reserved

The above specifications are for reference purpose only and subjected to change without prior notice