

# RM807

## *Power Amplifier Module for TDMA PCS (1850–1910 MHz)*

The RM807 Power Amplifier Module (PAM) for Personal Communications Service (PCS) is a fully matched 6-pin surface mount module developed for PCS and wireless local loop applications. This small and efficient power amplifier packs a full 1850–1910 MHz bandwidth coverage into a single compact package. This device meets the stringent spectral linearity requirements of Time Division Multiple Access (TDMA) PCS transmission with high power added efficiency to output power of 29.5 dBm. A single Gallium Arsenide (GaAs) Microwave Monolithic Integrated Circuit (MMIC) contains all active circuitry in the module. The MMIC contains onboard bias circuitry as well as input and interstage matching circuits. The output match is realized off-chip within the module package to optimize efficiency and power performance into a 50 ohm load. This device is manufactured with Skyworks' GaAs Heterojunction Bipolar Transistor (HBT) process that provides for all positive voltage DC supply operation while maintaining high efficiency and good linearity. Primary bias to the RM807 can be supplied directly from a three-cell nickel cadmium, single cell lithium ion, or other suitable battery with output in the 3–4 volts range. Power down is accomplished by setting the voltage on the low current reference pin to zero volts. No external supply side switch is needed as typical "off" leakage is a few microamperes with full primary voltage supplied from the battery.

### Distinguishing Features

- Low voltage positive bias supply
- Good linearity
- High efficiency
- Large dynamic range
- 6-pin LCC package (6 x 6 x 1.5 mm)
- Power down control

### Applications

- Personal Communications Services (TDMA)
- Wireless Local Loop (WLL)

### Functional Block Diagram

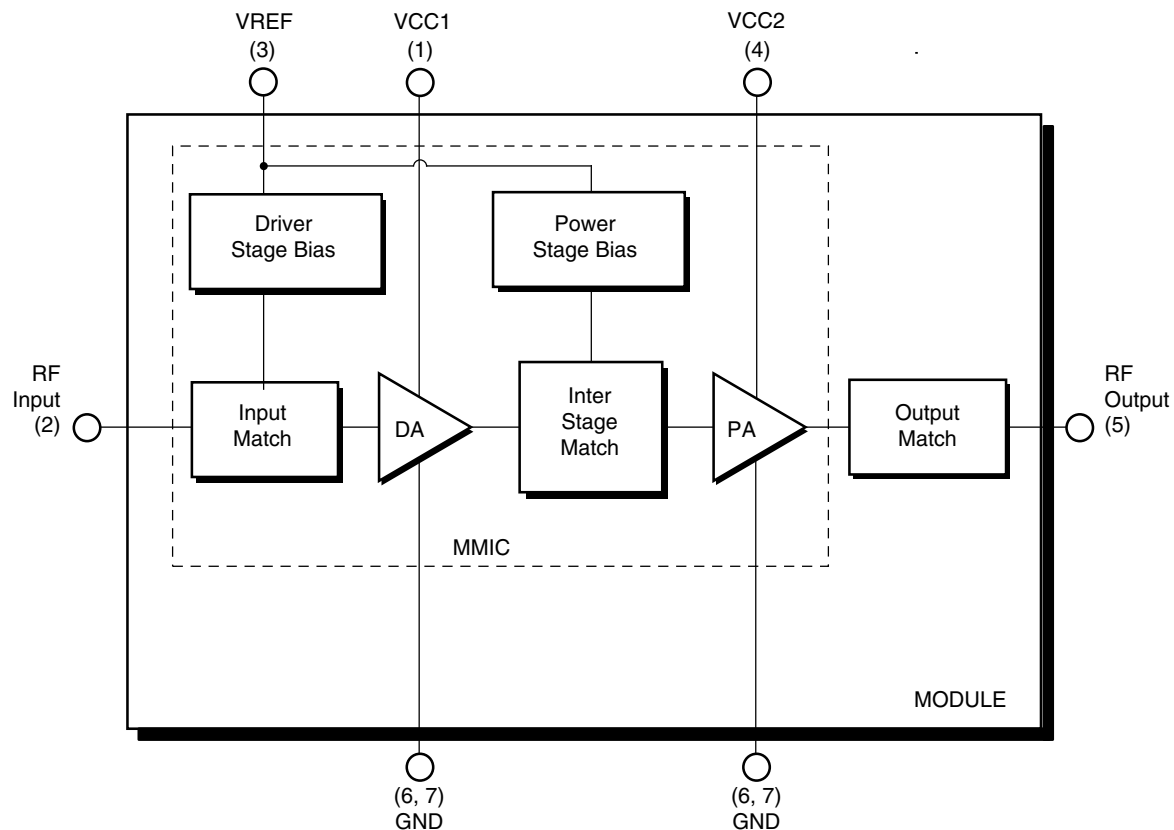

## Electrical Specifications

The following tables list the electrical characteristics for the RM807 Power Amplifier. Table 1 lists the absolute maximum rating for continuous operation. Table 2 lists the recommended operating conditions for achieving the electrical performance listed in Table 3, which contains the electrical performance data of the RM807 Power Amplifier under recommended operating conditions.

**Table 1. Absolute Maximum Ratings<sup>(1)</sup>**

Parameter	Symbol	Minimum	Nominal	Maximum	Unit
RF Input Power	Pin	—	3.0	8.0	dBm
Supply Voltage	Vcc	—	3.5	5.0 <sup>(2)</sup>	Volts
Reference Voltage	Vref	—	3.1	3.3	Volts
Case Operating Temperature	Tc	–30	+25	+110	°C
Storage Temperature	Tstg	–55	—	+125	°C
<b>NOTE(S):</b> (1) No damage assuming only one parameter is set at limit at a time with all other parameters set at or below nominal value. (2) Under pulsed TDMA modulated mode, operation at maximum supply voltage of 6.2 V up to 100 ms.					

**Table 2. Recommended Operating Conditions**

Parameter	Symbol	Minimum	Nominal	Maximum	Unit
Supply Voltage	Vcc	3.0	3.5	4.2	Volts
Reference Voltage	Vref	3.0	3.1	3.3	Volts
Operating Frequency	Fo	1850	1880	1910	MHz
Operating Temperature	To	–30	+25	+85	°C

Power Amplifier Module for TDMA PCS (1850–1910 MHz)

**Table 3. Electrical Specifications for TDMA/PCS Nominal Operating Conditions<sup>(1)</sup>**

Characteristic	Condition	Symbol	Minimum	Typical	Maximum	Unit
Quiescent current	—	I <sub>q</sub>	—	120.0	140.0	mA
Reference current	—	I <sub>ref</sub>	—	2.0	3.0	mA
Leakage current	PA off		—	4.5	25.0	μA
Gain	P <sub>o</sub> = 0 dBm	G	26.0	30.0	31.5	dB
	P <sub>o</sub> = 29.5 dBm	G <sub>p</sub>	26.0	29.0	31.5	dB
Power Added Efficiency	—	PAED	32.0	37.0	—	%
Adjacent Channel Power	—30 kHz offset	ACP1	—	-30.0	-28.5	dBc
	-60 kHz offset	ACP2	—	-51.0	-47.0	dBc
	-90 kHz offset	ACP3	—	-55.0	—	dBc
Harmonics	Second	DFo2	—	-49.0	—	dBc
	Third	DFo3	—	-60.0	—	dBc
PA “Turn off time”	—	—	—	10.0	—	μS
PA “Turn on time”	—	—	—	10.0	—	μS
Noise Power in RX band 1930 – 1990 MHz <sup>(2)</sup>	P <sub>o</sub> ≤ 29.5 dBm	N <sub>p</sub>	—	-136.5	-136.0	dBm/Hz
Noise Figure	—	NF	—	6.0	—	dB
Input Voltage Standing Wave Ratio	—	VSWR	—	1.5:1	1.8:1	—
Stability (spurious output)	5:1 VSWR all phases	S	—	—	-60.0	dBc
Ruggedness—no damage	P <sub>o</sub> ≤ 29.5 dBm	R <sub>u</sub>	—	—	10:1	VSWR
<b>NOTE(S):</b>						
(1) TDMA MODE, V <sub>cc</sub> = +3.5 V, V <sub>ref</sub> = +3.1 V, Freq = 1880 MHz, T <sub>c</sub> = +25 °C.						
(2) With NADC modulation applied.						

Table 4. Electrical Specifications for TDMA/PCS Recommended Operating Conditions<sup>(1)</sup>

Characteristic	Condition	Symbol	Minimum	Maximum	Unit
Quiescent current	—	I <sub>q</sub>	—	150.0	mA
Reference current	—	I <sub>ref</sub>	—	9.0	mA
Leakage current <sup>(3)</sup>	PA off		—	25.0	μA
Gain	P <sub>o</sub> = 0 dBm	G	24.0	32.5	dB
	P <sub>o</sub> = 29.5 dBm	G <sub>p</sub>	23.0	34.0	dB
Power Added Efficiency	—	PAED	30.0	—	%
Adjacent Channel Power	—30 kHz offset	P <sub>o</sub> ≤ 29.5 dBm ACP1	—	-26.0	dBc
	-60 kHz offset	P <sub>o</sub> ≤ 29.5 dBm ACP2	—	-46.0	dBc
	-90 kHz offset	P <sub>o</sub> ≤ 29.5 dBm ACP3	—	-50.0	dBc
Harmonics	Second	P <sub>o</sub> ≤ 29.5 dBm DFo2	—	-35.0	dBc
	Third	P <sub>o</sub> ≤ 29.5 dBm DFo3	—	-35.0	dBc
PA “Turn off time”	—	—	—	30.0	μS
PA “Turn on time”	—	—	—	30.0	μS
Noise Power in RX band 1930 – 1990 MHz <sup>(2)</sup>	P <sub>o</sub> ≤ 29.5 dBm	N <sub>p</sub>	—	-133.0	dBm/Hz
Input Voltage Standing Wave Ratio	—	VSWR	—	2.3:1	—
Stability (spurious output) <sup>(3)</sup>	5:1 VSWR all phases	S	—	-60.0	dBc
Ruggedness—no damage <sup>(3)</sup>	P <sub>o</sub> ≤ 29.5 dBm	R <sub>u</sub>	—	10:1	VSWR
<p><b>NOTE(S):</b>            (1) TDMA MODE, V<sub>cc</sub> = +3.5 V, V<sub>ref</sub> = +3.1 V, Freq = 1850 – 1910 MHz, T<sub>c</sub> = -30 °C to +85 °C.            (2) With NADC modulation applied.            (3) T<sub>c</sub> = +25 °C.</p>					

## Characterization Data

The following charts illustrate the characteristics of a typical RM807 Power Amplifier tested in the evaluation board described in the following section. The amplifier was selected by characterizing a group of devices and choosing a part with average electrical performance at both nominal and worst case conditions. Figures 1 through 5 illustrate the digital signal characteristics of the RM807.

Figure 1. Digital Gain vs. Output Power

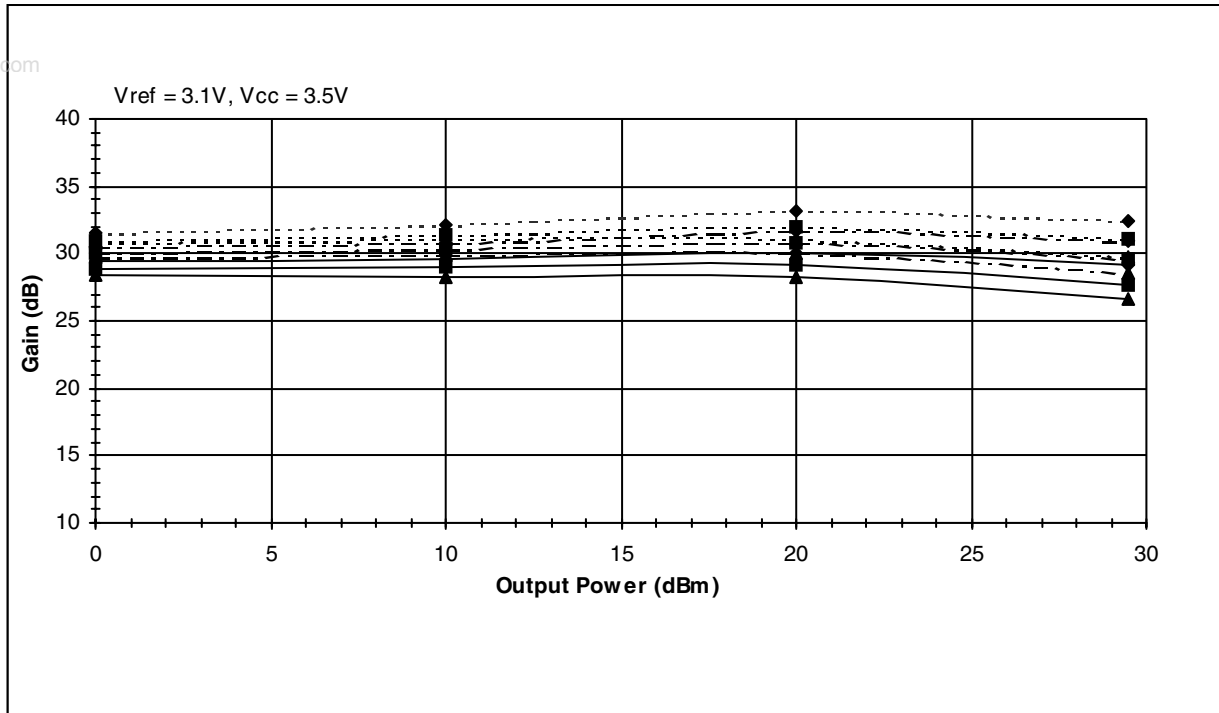

···◆··· 1850 MHz @ -30 C	—◆— 1850 MHz @ +85 C	--◆-- 1850 MHz @ +25 C
···■··· 1880 MHz @ -30 C	—■— 1880 MHz @ +85 C	--■-- 1880 MHz @ +25 C
···▲··· 1910 MHz @ -30 C	—▲— 1910 MHz @ +85 C	--▲-- 1910 MHz @ +25 C

Figure 2. Digital Adjacent Channel Power vs. Output Power

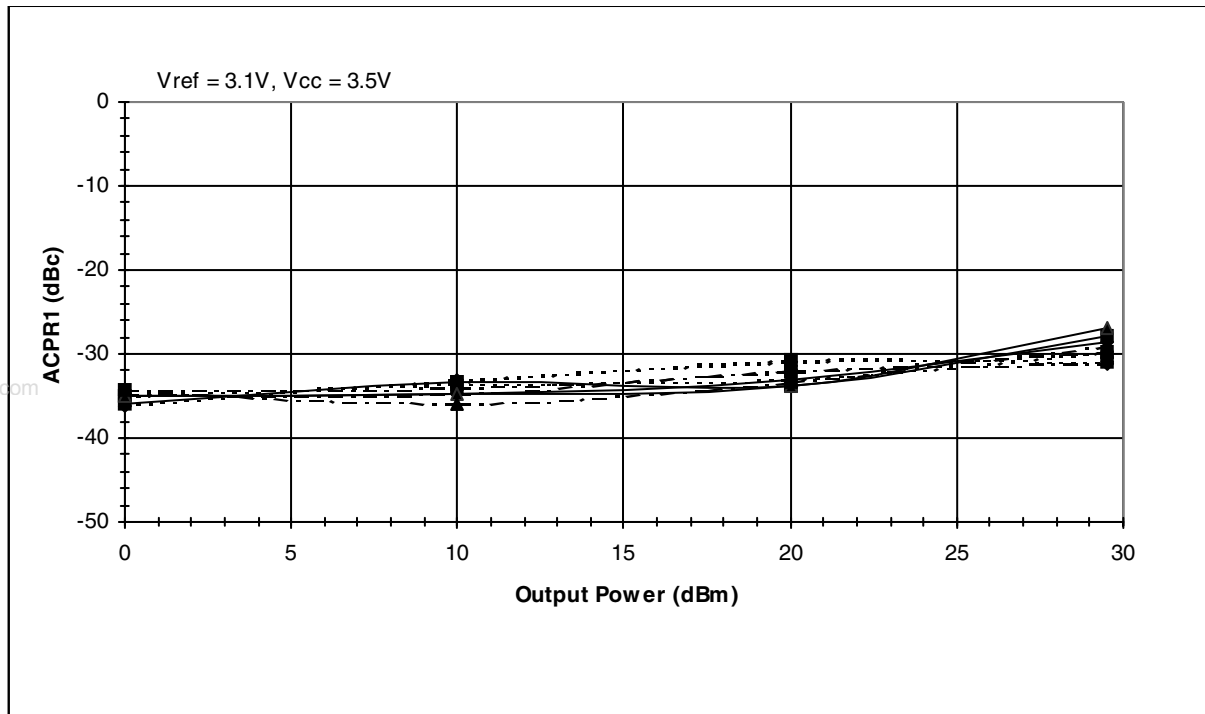
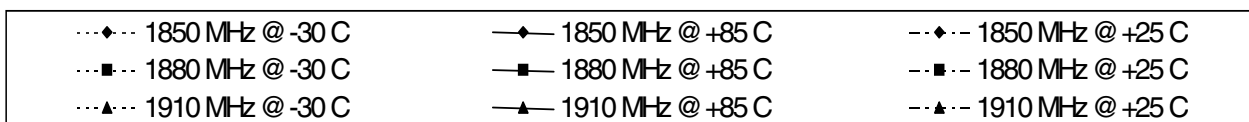
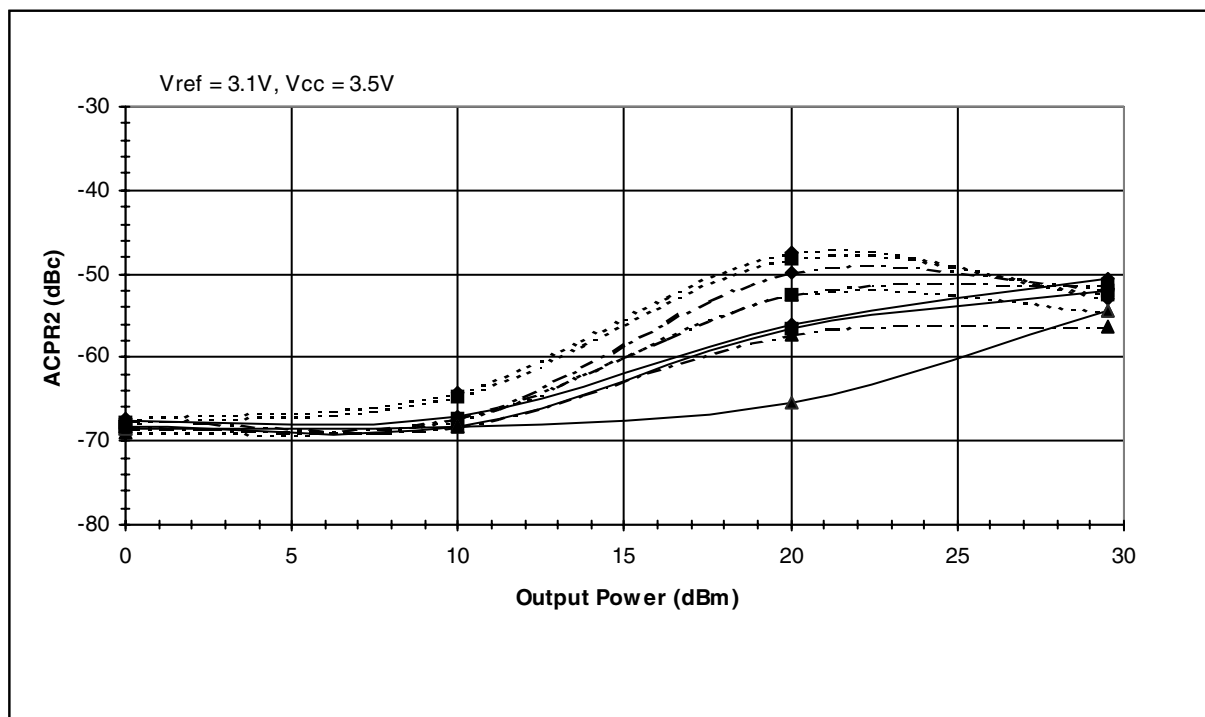

Figure 3. Digital Alternate Channel Power vs. Output Power



Power Amplifier Module for TDMA PCS (1850–1910 MHz)

Figure 4. Digital Power Added Efficiency vs. Output Power

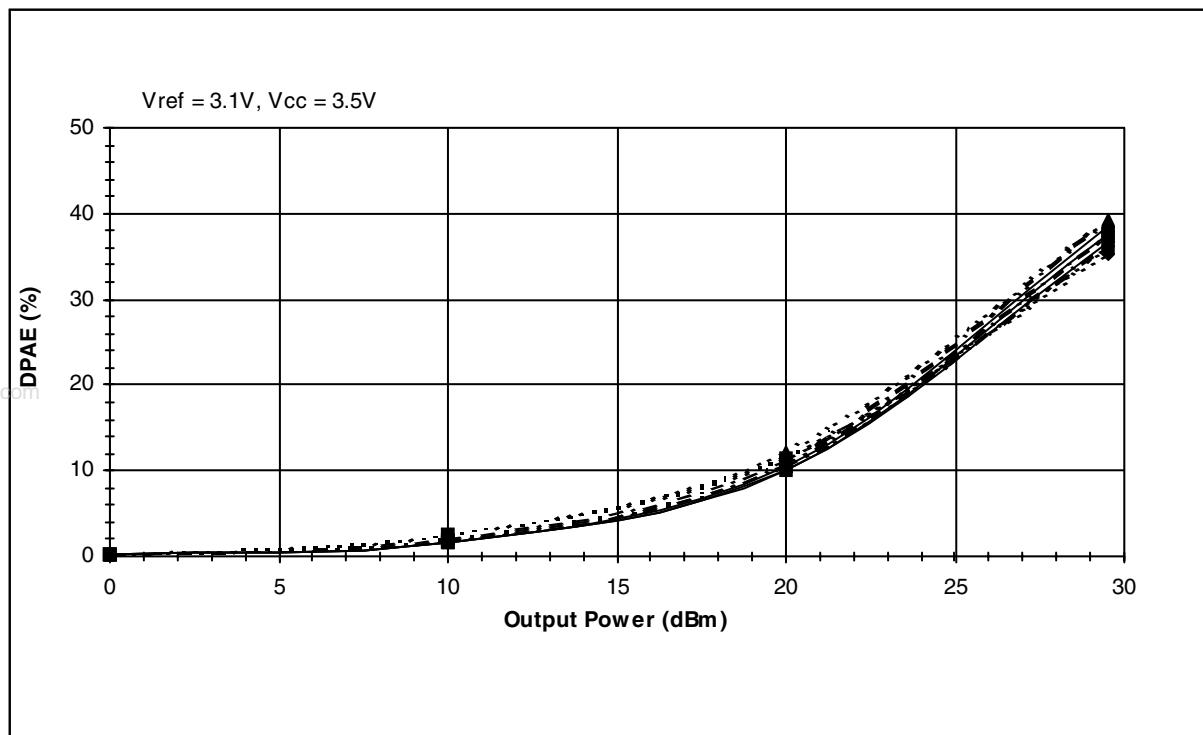
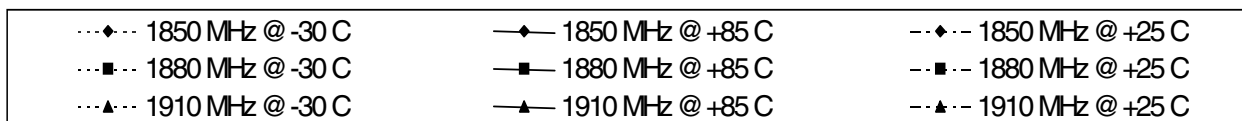
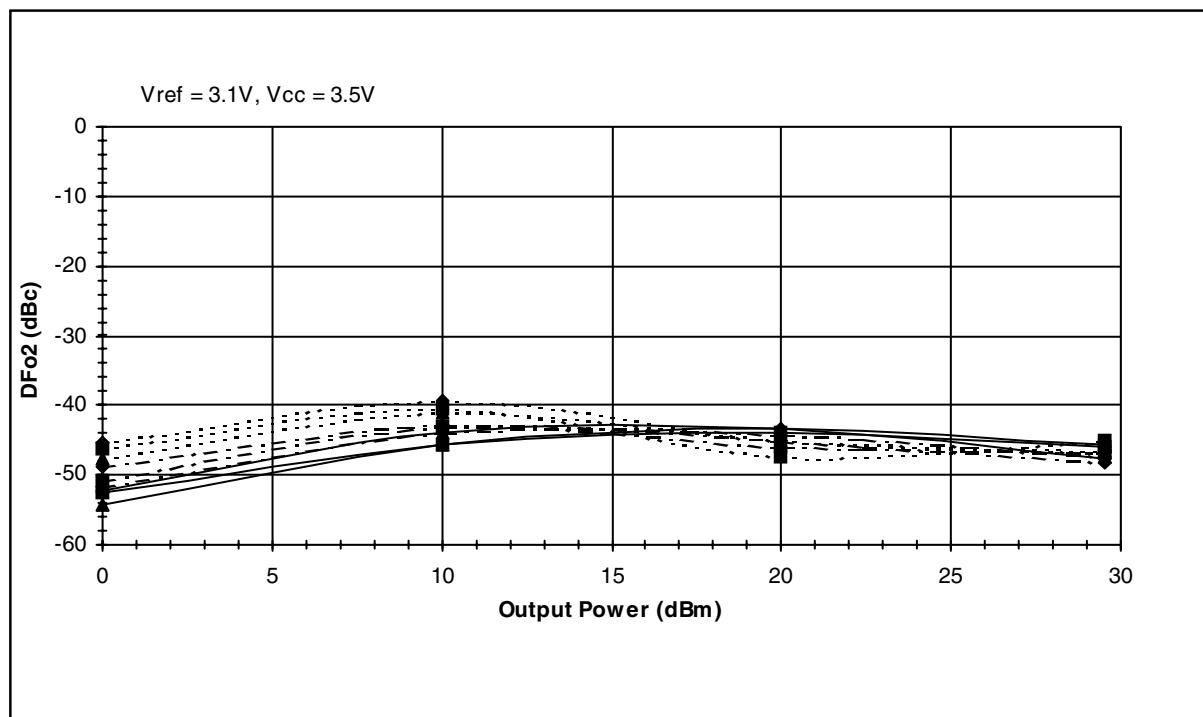

Figure 5. Analog Second Order Harmonic Suppression vs. Output Power



# Evaluation Board Description

The evaluation board is a platform for testing and interfacing design circuitry. To accommodate the interface testing of the RM807, the evaluation board schematic and diagrams are included for preliminary analysis and design. Figure 6 shows the basic schematic of the board for the 1850 MHz to 1910 MHz range. Figure 7 illustrates the board layout.

**Figure 6. Evaluation Board Schematic**

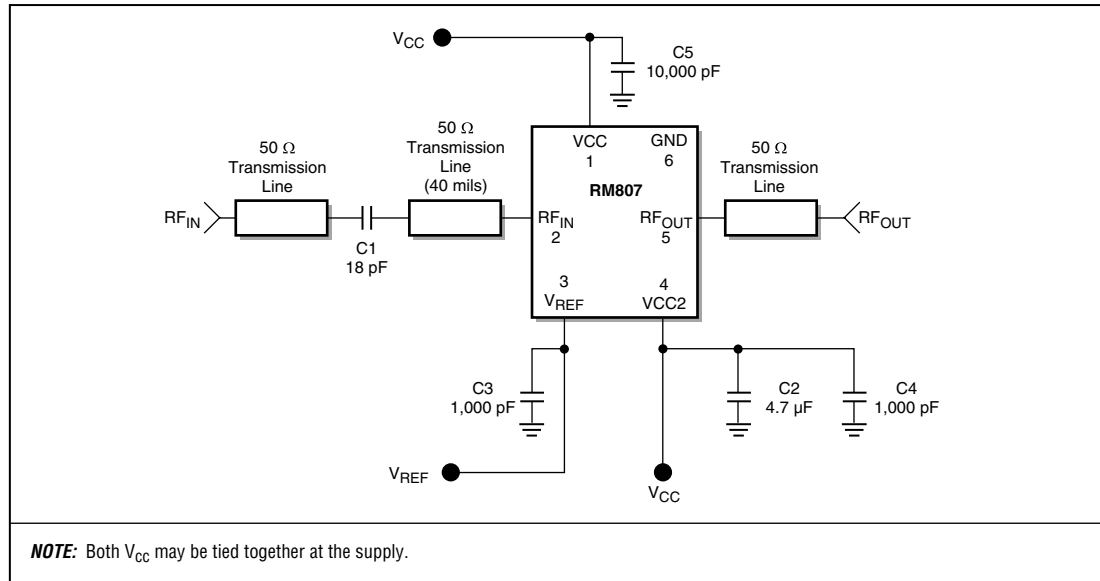

100409\_003

**Figure 7. Evaluation Board Diagram**

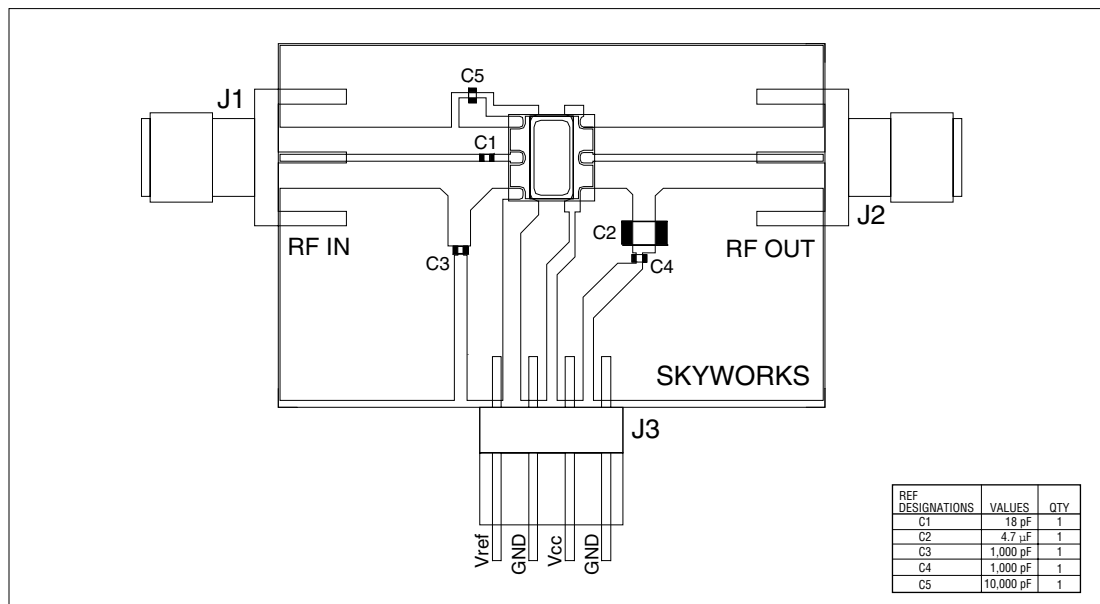

100409\_004



## Package Dimensions and Pin Description

The RM807 is a multi-layer laminate base, overmold encapsulated modular package designed for surface mount solder attachment to a printed circuit board.

Figure 8. RM807 Package Drawing

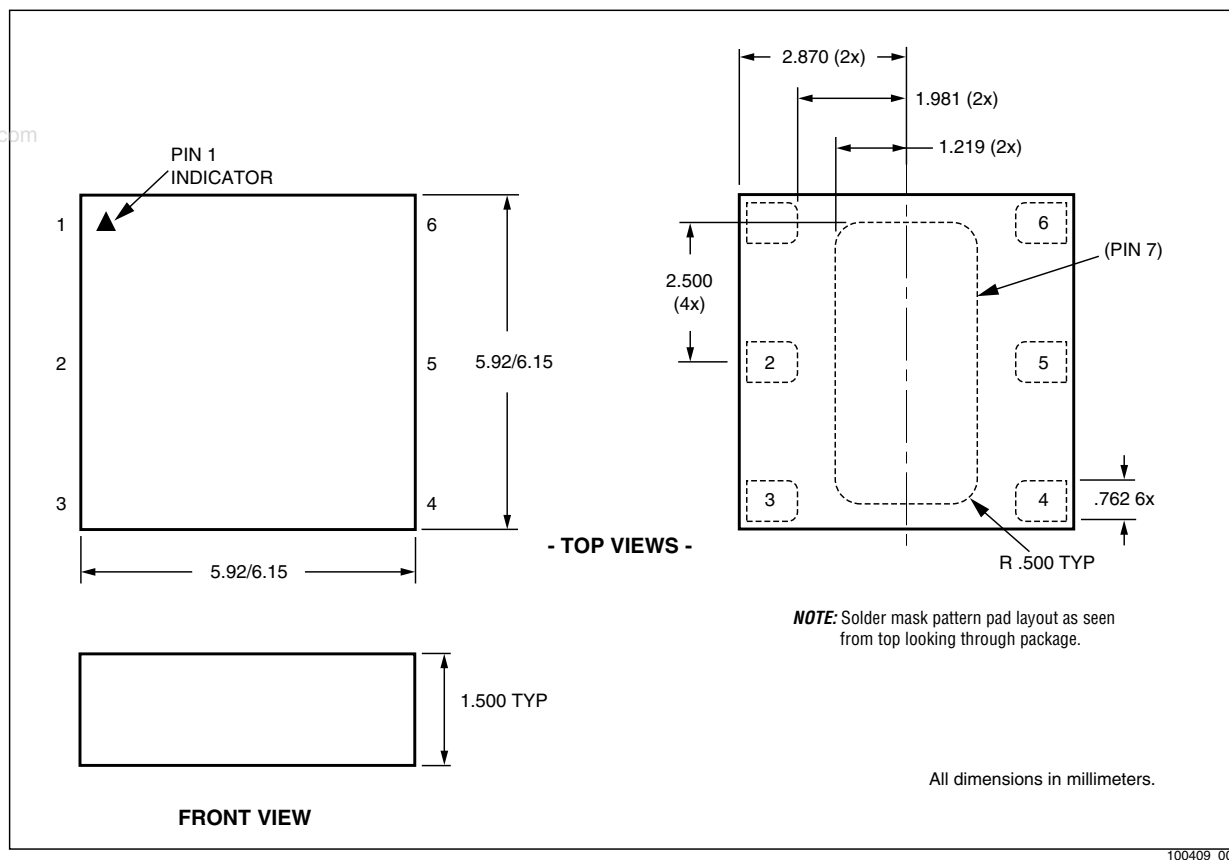

Table 5. Pin Description

Pin #	Function
1	VCC1 <sup>(1)</sup>
2	RF Input
3	VREF
4	VCC2 <sup>(1)</sup>
5	RF Output
6	GND
(7) GND PAD	GND <sup>(2)</sup>

**NOTE(S):**

(1) All supply pins may be connected together at the supply.

(2) Package underside is GND.

## Package and Handling Information

Because of its sensitivity to moisture absorption, this device package is baked and vacuum packed prior to shipment. Instructions on the shipping container label must be followed regarding exposure to moisture after the container seal is broken, otherwise, problems related to moisture absorption may occur when the part is subjected to high temperature during solder assembly.

The RM807 is capable of withstanding an MSL 3/225 °C solder reflow. Care must be taken when attaching this product, whether it is done manually or in a production solder reflow environment. If the part is attached in a reflow oven, the temperature ramp rate should not exceed 5 °C per second; maximum temperature should not exceed 225 °C. If the part is manually attached, precaution should be taken to insure that the part is not subjected to temperatures exceeding 225 °C for more than 10 seconds. For details on both attachment techniques, precautions, and handling procedures recommended by Conexant, please refer to *Application Note: PCB Design and SMT Assembly/Rework, Document Number 101752*. Additional information on standard SMT reflow profiles can also be found in the *JEDEC Standard J-STD-020A*.

Production quantities of this product are shipped in the standard tape-and-reel format. For packaging details, refer to *Application Note: Tape and Reel, Document Number 101568*.

**Figure 9. Typical Case Markings**

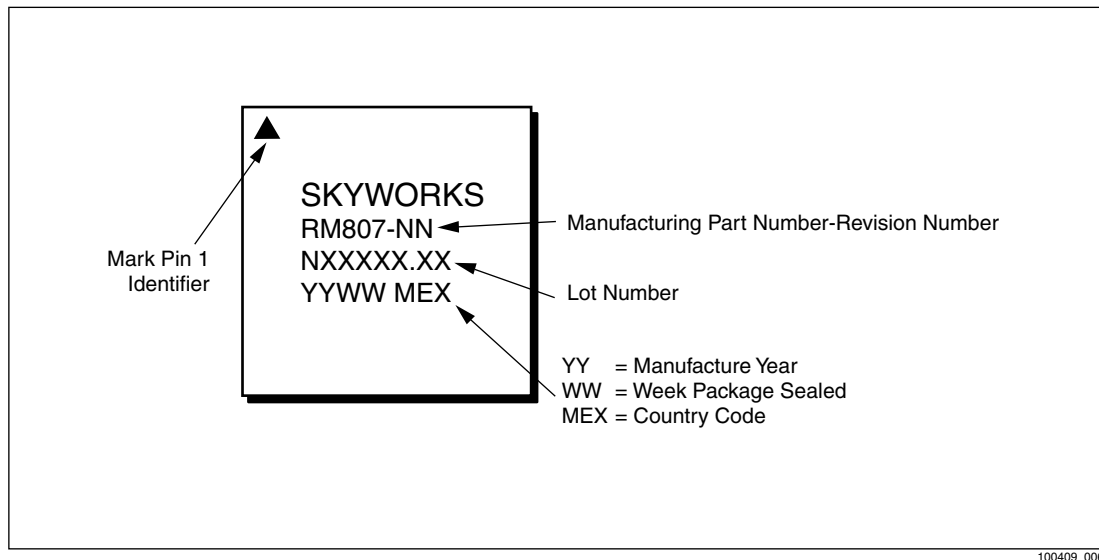

## Electrostatic Discharge Sensitivity

The RM807 is a Class I device. Figure 10 lists the Electrostatic Discharge (ESD) immunity level for each pin of the RM807 product. The numbers in Figure 10 specify the ESD threshold level for each pin where the I-V curve between the pin and ground starts to show degradation. The ESD testing was performed in compliance with MIL-STD-883E Method 3015.7 using the Human Body Model. Since 2000 volts represents the maximum measurement limit of the test equipment used, pins marked > 2000 V pass 2000V ESD stress.

www.DataSheet4U.com

**Figure 10. ESD Sensitivity Areas**

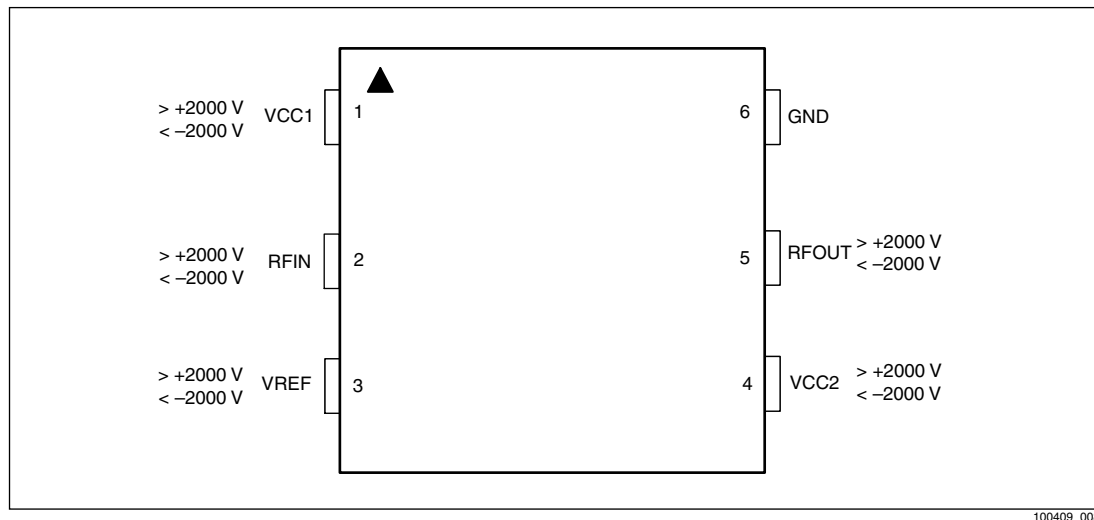

100409\_008

Various failure criteria can be utilized when performing ESD testing. Many vendors employ relaxed ESD failure standards which fail devices only after “the pin fails the electrical specification limits” or “the pin becomes completely non-functional”. Skyworks employs most stringent criteria, fails devices as soon as the pin begins to show any degradation on a curve tracer.

To avoid ESD damage, latent and visible, it is very important that the product assembly and test areas follow the Class-1 ESD handling precautions listed in Table 6.

**Table 6. Precautions for GaAs ICs with ESD Thresholds Greater Than 200V But Less Than 2000V**

<p align="center"><b>Personnel Grounding</b></p> <p>Wrist Straps Conductive Smocks, Gloves and Finger Cots Antistatic ID Badges</p>	<p align="center"><b>Facility</b></p> <p>Relative Humidity Control and Air Ionizers Dissipative Floors (less than <math>10^9 \Omega</math> to GND)</p>
<p align="center"><b>Protective Workstation</b></p> <p>Dissipative Table Tops Protective Test Equipment (Properly Grounded) Grounded Tip Soldering Irons Conductive Solder Suckers Static Sensors</p>	<p align="center"><b>Protective Packaging &amp; Transportation</b></p> <p>Bags and Pouches (Faraday Shield) Protective Tote Boxes (Conductive Static Shielding) Protective Trays Grounded Carts Protective Work Order Holders</p>

www.DataSheet4U.com

## Ordering Information

Model Number	Manufacturing Part Number	Product Revision	Package	Operating Temperature
RM807	RM807-15	15	6x6LM-6	-30 °C to +85 °C

## Revision History

Revision	Level	Date	Description
A		March 2000	Initial Release
B		March 2000	Amend Title, Added Package Drawing
C		March 2001	Add Soldering and Temperature Change Guidelines, Evaluation Board information, Case Marking drawing, ESD data
D		April 2001	Revise: Manufacturing Part Number; Figure 3; ESD Data Add: Table 4; Figures 1 through 5, Packaging and Handling Information Section
E		September 2001	Revise: Add footnote to Table 1
F		February 7, 2002	Revise: Table 1 footnote 2.

## References

Application Note: PCB Design and SMT Assembly/Rework, Document Number 101752

Application Note: Tape and Reel, Document Number 101568

JEDEC Standard J-STD-020A

© 2002, Skyworks Solutions, Inc. All Rights Reserved.

Information in this document is provided in connection with Skyworks Solutions, Inc. ("Skyworks") products. These materials are provided by Skyworks as a service to its customers and may be used for informational purposes only. Skyworks assumes no responsibility for errors or omissions in these materials. Skyworks may make changes to its products, specifications and product descriptions at any time, without notice. Skyworks makes no commitment to update the information and shall have no responsibility whatsoever for conflicts, incompatibilities, or other difficulties arising from future changes to its products and product descriptions.

No license, express or implied, by estoppel or otherwise, to any intellectual property rights is granted by this document. Except as may be provided in Skyworks' Terms and Conditions of Sale for such products, Skyworks assumes no liability whatsoever.

THESE MATERIALS ARE PROVIDED "AS IS" WITHOUT WARRANTY OF ANY KIND, EITHER EXPRESS OR IMPLIED, RELATING TO SALE AND/OR USE OF SKYWORKS™ PRODUCTS INCLUDING WARRANTIES RELATING TO FITNESS FOR A PARTICULAR PURPOSE, MERCHANTABILITY, PERFORMANCE, QUALITY OR NON-INFRINGEMENT OF ANY PATENT, COPYRIGHT OR OTHER INTELLECTUAL PROPERTY RIGHT. SKYWORKS FURTHER DOES NOT WARRANT THE ACCURACY OR COMPLETENESS OF THE INFORMATION, TEXT, GRAPHICS OR OTHER ITEMS CONTAINED WITHIN THESE MATERIALS. SKYWORKS SHALL NOT BE LIABLE FOR ANY SPECIAL, INDIRECT, INCIDENTAL, OR CONSEQUENTIAL DAMAGES, INCLUDING WITHOUT LIMITATION, LOST REVENUES OR LOST PROFITS THAT MAY RESULT FROM THE USE OF THESE MATERIALS.

Skyworks™ products are not intended for use in medical, lifesaving or life-sustaining applications. Skyworks' customers using or selling Skyworks™ products for use in such applications do so at their own risk and agree to fully indemnify Skyworks for any damages resulting from such improper use or sale.

The following are trademarks of Skyworks Solutions, Inc.: Skyworks™, the Skyworks symbol, and "Breakthrough Simplicity"™. Product names or services listed in this publication are for identification purposes only, and may be trademarks of third parties. Third-party brands and names are the property of their respective owners.

Additional information, posted at [www.skyworksinc.com](http://www.skyworksinc.com), is incorporated by reference.

General Information:  
Skyworks Solutions, Inc.  
4311 Jamboree Rd.  
Newport Beach, CA. 92660-3007  
[www.skyworksinc.com](http://www.skyworksinc.com)

