

# RMTR10300

## 10-30 GHz Tripler MMIC

ADVANCED INFORMATION

### Description

The RMTR10300 is a 10 to 30 GHz Tripler designed to be used in the LO chain of point to point radios, point to multi-point communications, LMDS, and other millimeter wave applications. The RMTR10300 is a three stage amplifier in which the first stage acts as a harmonic generator followed by two stages of amplification at 3Fo. The RMTR10300 utilizes Raytheon's advanced 0.15  $\mu$ m gate length PHEMT process and is sufficiently versatile to serve in a variety of multiplier applications.

### Features

- ◆ 2 mil substrate
- ◆ Conversion Loss 0 dBm (typ.)
- ◆ Wide operating bandwidth
- ◆ Chip size 3.224 mm x 1.134 mm

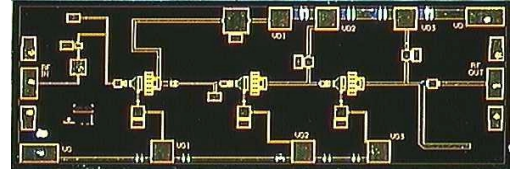

### Absolute Maximum Ratings

Parameter	Symbol	Value	Unit
Positive DC Voltage (+5 V Typical)	Vd	+ 6	Volts
Negative DC Voltage	Vg	- 2	Volts
Simultaneous (Vd - Vg)	Vdg	+ 8	Volts
Positive DC Current	Id	187	mA
RF Input Power (from 50 $\Omega$ source)	P <sub>IN</sub>	+22	dBm
Operating Baseplate Temperature	T <sub>C</sub>	-30 to +85	$^{\circ}$ C
Storage Temperature Range	T <sub>stg</sub>	-55 to +125	$^{\circ}$ C
Thermal Resistance (Channel to Backside)	R <sub>jc</sub>	117	$^{\circ}$ C/W

### Electrical Characteristics

(At 25 $^{\circ}$ C), 50  $\Omega$  system,  
Vd = +5 V, Quiescent  
current (Idq)= 75 mA,  
Pin=+17 dBm

Parameter	Min	Typ	Max	Unit
Input Frequency Range	9		10.75	GHz
Output Frequency Range	27		32.25	GHz
Gate Supply Voltage (Vg) <sup>1</sup>		- 0.2		V
Input Drive Power @ Fo	+15	+17		dBm
Output Power @ 3Fo		+17		dBm

Parameter	Min	Typ	Max	Unit
Conversion Loss		0		dBm
Fundamental Rejection		-30		dBc
2nd Harmonic Rejection		-15		dBc
4th Harmonic Rejection		-25		dBc
Input Return Loss		8		dB
Output Return Loss		7		dB

**Note:** 1. Typical range of the negative gate voltage is -0.5 to 0.0V to set typical Idq of 75 mA.

**Characteristic performance data and specifications are subject to change without notice.**

# RMTR10300

## 10 – 30 GHz Tripler MMIC

ADVANCED INFORMATION

**Application Information**

**CAUTION: THIS IS AN ESD SENSITIVE DEVICE.**

Chip carrier material should be selected to have GaAs compatible thermal coefficient of expansion and high thermal conductivity such as copper molybdenum or copper tungsten. The chip carrier should be machined, finished flat, plated with gold over nickel and should be capable of withstanding 325°C for 15 minutes.

Die attachment should utilize Gold/Tin (80/20) eutectic alloy solder and should avoid hydrogen environment for PHEMT devices. Note that the backside of the chip is gold plated and is used as RF ground.

These GaAs devices should be handled with care and stored in dry nitrogen environment to prevent contamination of bonding surfaces. These are ESD sensitive devices and should be handled with appropriate precaution including the use of wrist grounding straps. All die attach and wire/ribbon bond equipment must be well grounded to prevent static discharges through the device.

Recommended wire bonding uses 3 mils wide and 0.5 mil thick gold ribbon with lengths as short as practical allowing for appropriate stress relief. The RF input and output bonds should be typically 0.012" long corresponding to a typically 2 mil between the chip and the substrate material.

**Figure 1**  
Functional Block Diagram

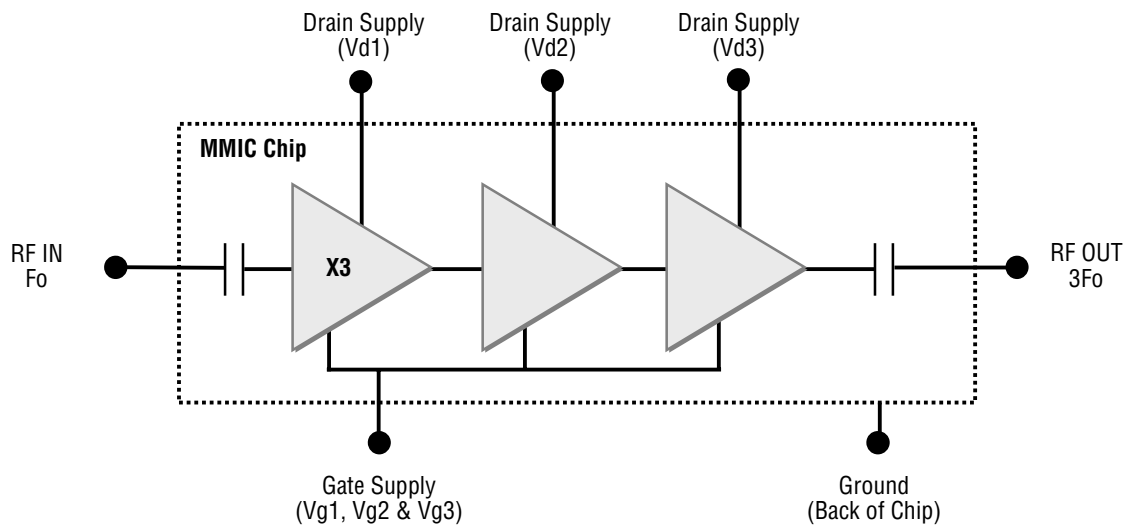

**Figure 2**  
Chip Layout and Bond Pad Locations

Chip Size is 3.224 mm x 1.134 mm. Back of chip is RF ground.

Dimensions in mm

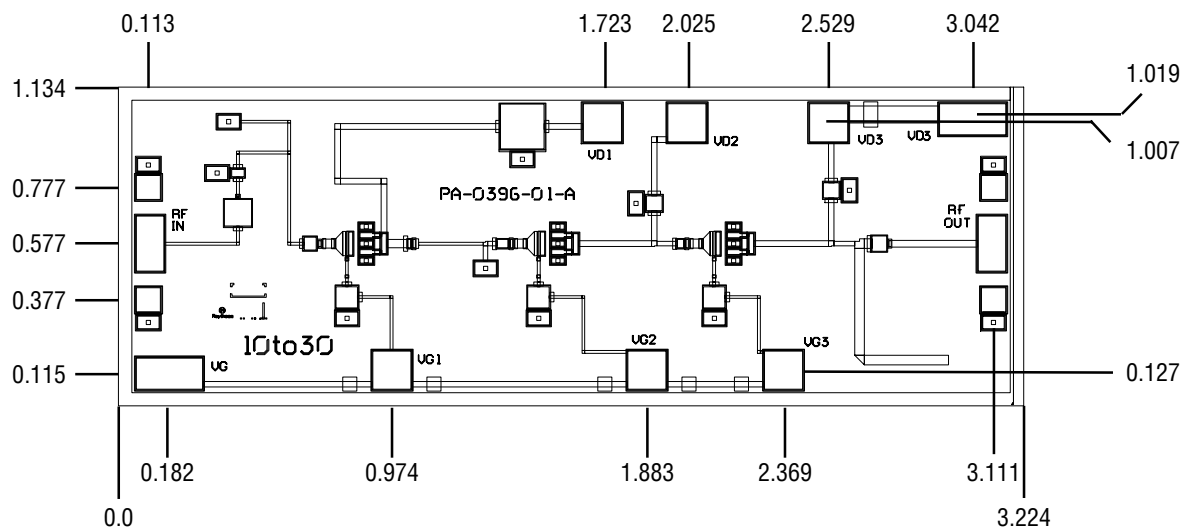

Characteristic performance data and specifications are subject to change without notice.

# RMTR10300

## 10 – 30 GHz Tripler MMIC

**Figure 3**  
Recommended  
Application Schematic  
Circuit Diagram

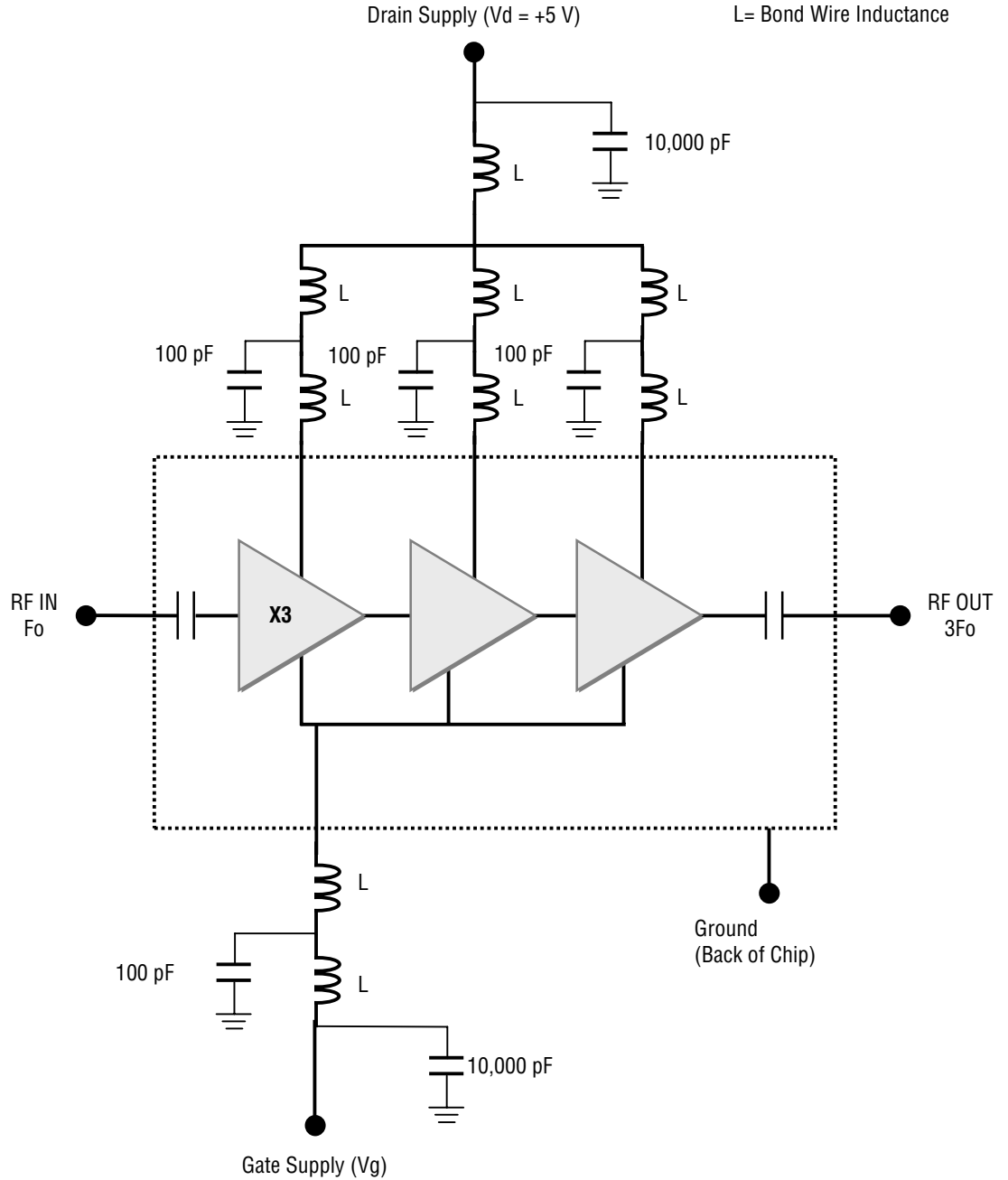

Characteristic performance data and specifications are subject to change without notice.

# RMTR10300

## 10 – 30 GHz Tripler MMIC

**Figure 4**  
Recommended  
Assembly Diagram

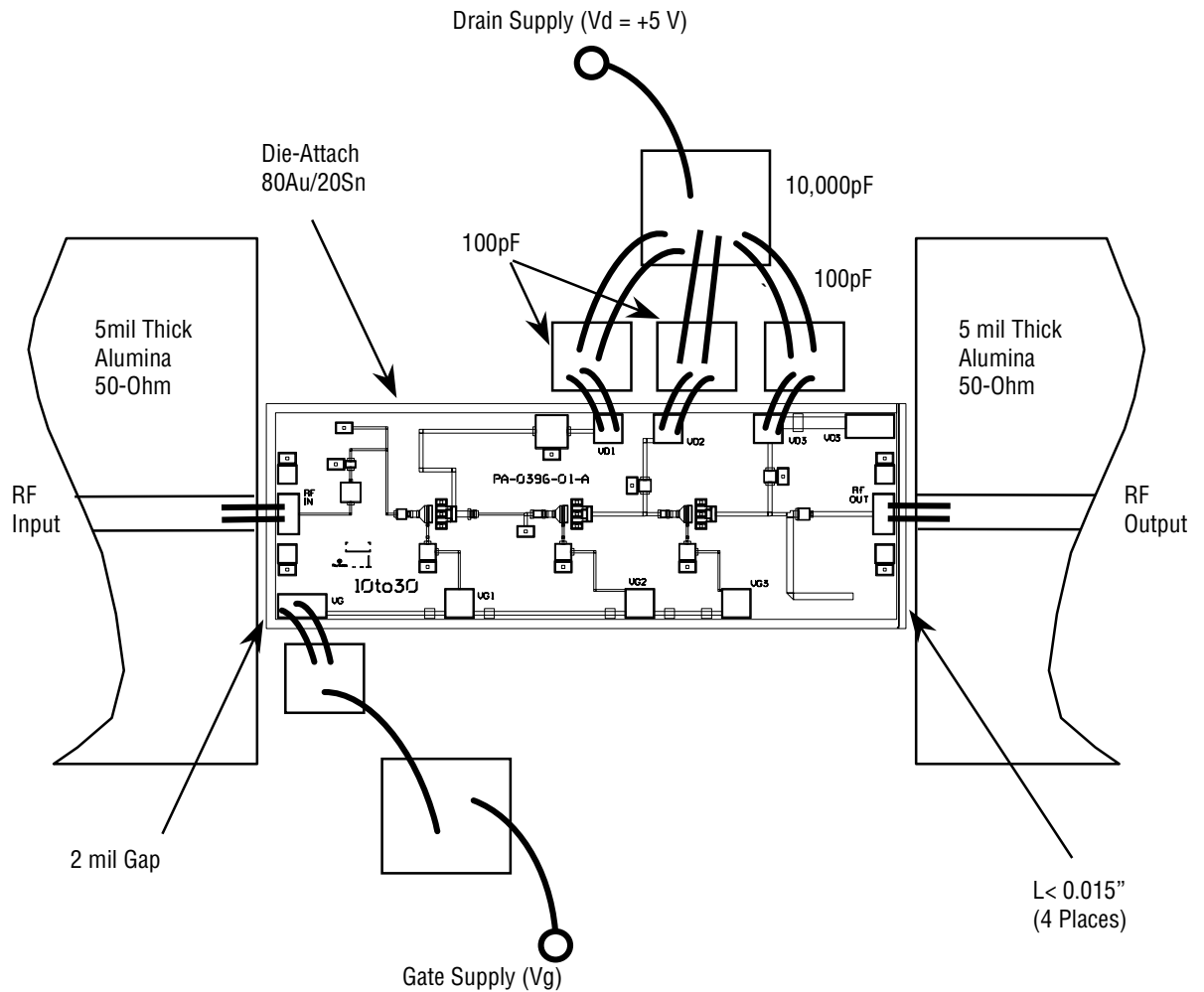

**Note:** Use 0.003" by 0.0005" Gold Ribbon for bonding. RF input and output bonds should be less than 0.015" long with stress relief.

**Recommended  
Procedure**  
for Biasing and  
Operation

**CAUTION: LOSS OF GATE VOLTAGE (VG) WHILE DRAIN VOLTAGE (VD) IS PRESENT MAY DAMAGE THE AMPLIFIER CHIP.**

The following sequence of steps must be followed to properly test the amplifier:

- Step 1:** Turn off RF input power.
- Step 2:** Connect the DC supply grounds to the ground of the chip carrier. Slowly apply negative gate bias supply voltage of -1.5 V to Vg.
- Step 3:** Slowly apply positive drain bias supply voltage of +5 V to Vd.
- Step 4:** Adjust gate bias voltage to set the quiescent current of Idq=75 mA.

- Step 5:** After the bias condition is established, the RF input signal may now be applied at the appropriate frequency band.
- Step 6:** Follow turn-off sequence of:
  - (i) Turn off RF input power.
  - (ii) Turn down and off drain voltage (Vd).
  - (iii) Turn down and off gate bias voltage (Vg).

Characteristic performance data and specifications are subject to change without notice.

# RMTR10300

## 10 – 30 GHz Tripler MMIC

Performance Data

**RMTR10300 Fixtured Data**  
 Vd = 5V Vg = -0.2V Id = 75mA w/o RF  
 All Gates and Drains Separated on chip  
 Pin = 17 dBm

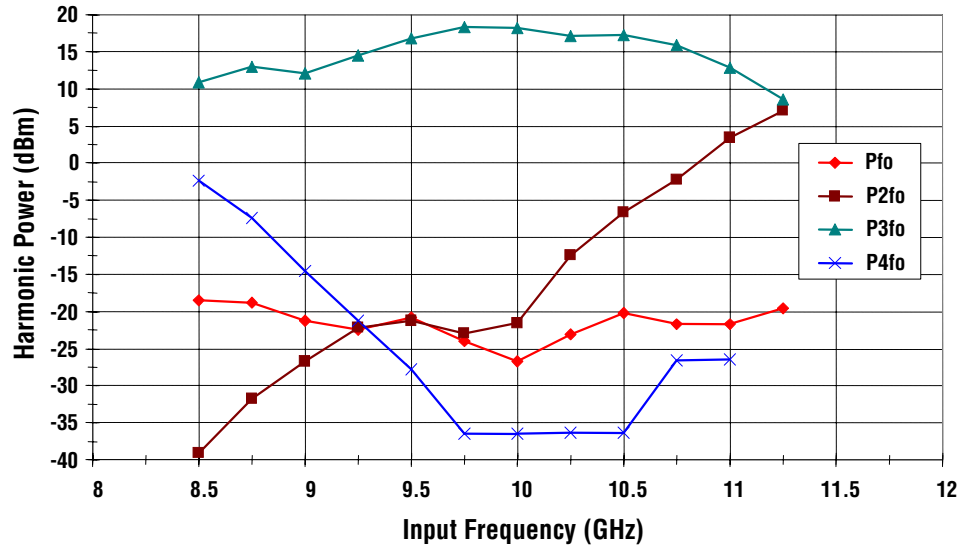

**RMTR10300 Fixtured Data**  
 Vd = 5V Vg = -0.2V Id = 75mA w/o RF  
 All Gates and Drains Separated on chip (S)  
 Pin = 15, 17 & 19 dBm

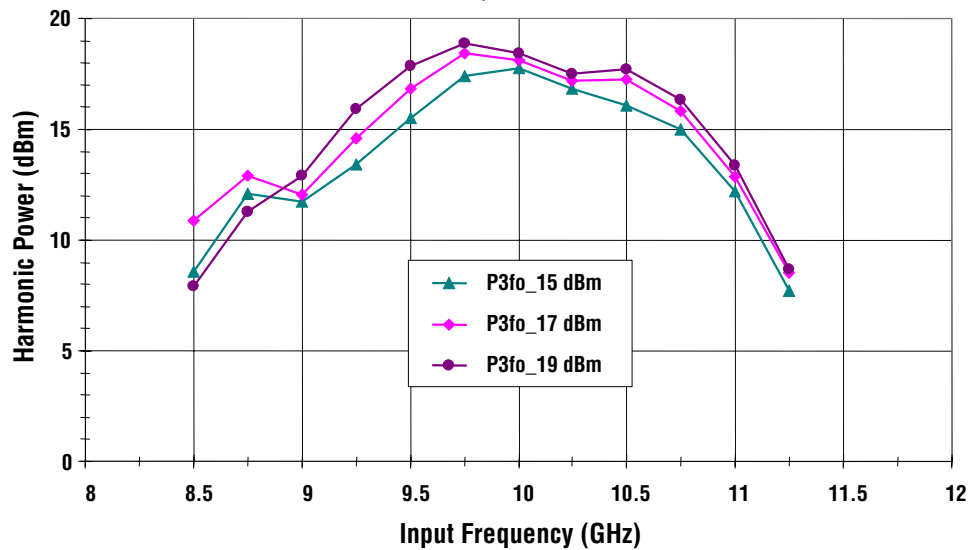

Characteristic performance data and specifications are subject to change without notice.

# RMTR10300

## 10 – 30 GHz Tripler MMIC

Performance  
Data

**RMTR10300 Fixtured Data**  
**Input Return Loss**  
 Vd = 5V Id = 75mA Vg = -0.2V  
 All Gates & Drains Separated on chip

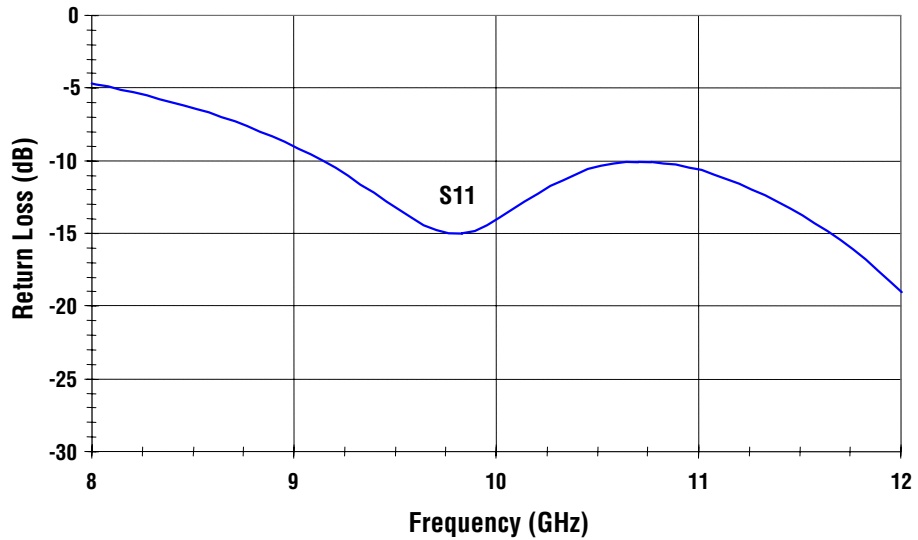

**RMTR10300 Fixtured Data**  
**Output Return Loss**  
 Vd = 5V Id = 75mA Vg = -0.2V  
 All Gates & Drains Separated on chip

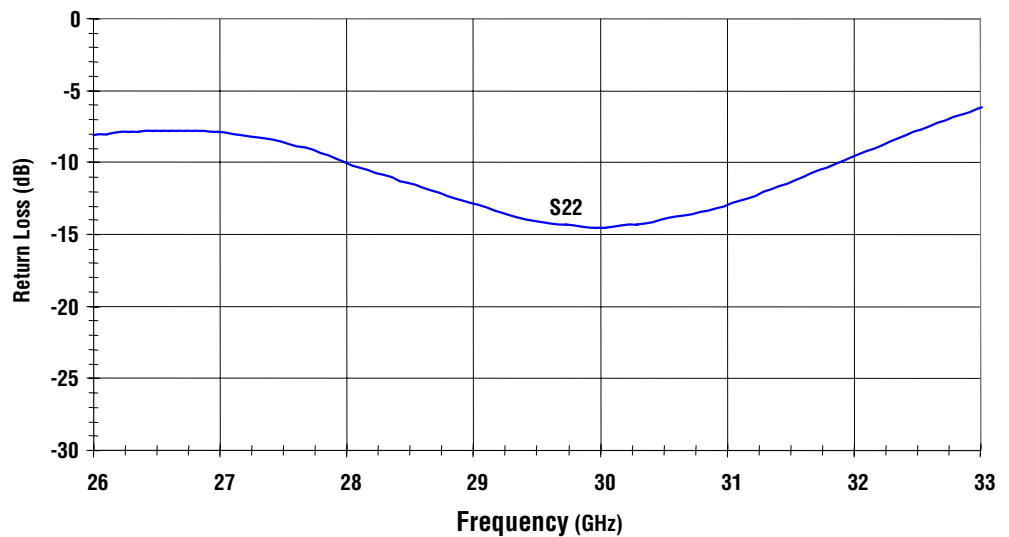

Characteristic performance data and specifications are subject to change without notice.

# Worldwide Sales Representatives

**North America**

**D&L Technical Sales**  
6139 S. Rural Road, #102  
Tempe, AZ 85283  
480-730-9553  
fax: 480-730-9647  
Nicholas Delvecchio, Jr.  
dlarizona@aol.com

**Hi-Peak Technical Sales**  
P.O. Box 6067  
Amherst, NH 03031  
866-230-5453  
fax: 603-672-9228  
sales@hi-peak.com

**Spartech South**  
2115 Palm Bay Road, NE,  
Suite 4  
Palm Bay, FL 32904  
321-727-8045  
fax: 321-727-8086  
Jim Morris  
jim@spartech-south.com

**TEQ Sales, Inc.**  
920 Davis Road, Suite 304  
Elgin, IL 60123  
847-742-3767  
fax: 847-742-3947  
Dennis Culpepper  
dculpepper@teqsales.com

**Cantec Representatives**  
8 Strathearn Ave, No. 18  
Brampton, Ontario  
Canada L6T 4L9  
905-791-5922  
fax: 905-791-7940  
Dave Batten  
cantec-ott@cantec-o.net

**Steward Technology**  
6990 Village Pkwy #206  
Dublin, CA 94568  
925-833-7978  
fax: 925-560-6522  
John Steward  
johnsteward1@msn.com

**Europe**

**Sangus OY**  
Lunkintie 21,  
90460 Oulunsalo  
Finland  
358-8-8251-100  
fax: 358-8-8251-110  
Juha Virtala  
juha.virtala@sangus.fi

**Sangus AB**  
Berghamnvgen 68  
Box 5004  
S-165 10 Hasselby  
Sweden  
Ronny Gustafson  
468-0-380210  
fax: 468-0-3720954

**Globes Elektronik & Co.**  
Klarastrabe 12  
74072 Heilbronn  
Germany  
49-7131-7810-0  
fax: 49-7131-7810-20  
Ulrich Blievernicht  
hfwelt@globes.de

**MTI Engineering Ltd.**  
Afeq Industrial Park  
Hamelacha 11  
New Industrial Area  
Rosh Hayin 48091  
Israel  
972-3-902-5555  
fax: 972-3-902-5556  
Adi Peleg  
adi\_p@mti-group.co.il

**Sirces srl**  
Via C. Boncompagni, 3B  
20139 Milano  
Italy  
3902-57404785  
fax: 3902-57409243  
Nicola Iacovino  
nicola.iacovino@sirces.it

**Asia**

**ITX Corporation**  
2-5, Kasumigaseki  
3-Chome  
Chiyoda-Ku  
Tokyo 100-6014 Japan  
81-3-4288-7073  
fax: 81-3-4288-7243  
Maekawa Ryosuke  
maekawa.ryosuke@  
itx-corp.co.jp

**Sea Union**  
9F-1, Building A, No 19-3  
San-Chung Road  
Nankang Software Park  
Taiwan, ROC  
Taipei 115  
02-2655-3989  
fax: 02-2655-3918  
Murphy Su  
murphy@seaunionweb.com.tw

**Worldwide Distribution**

**Headquarters**  
6321 San Ignacio Drive  
San Jose, CA 95119  
408-360-4073  
fax: 408-281-8802  
Art Herbig  
art.herbig@avnet.com

**Belgium and Luxembourg**  
Cipalstraat  
2440 GEEL  
Belgium  
32 14 570670  
fax: 32 14 570679  
sales.be@bfioptilas.avnet.com

**United Kingdom**  
Burnt Ash Road  
Aylesford, Kent  
England  
ME207XB  
44 1622882467  
fax: 44 1622882469  
rfsales.uk@  
bfioptilas.avnet.com

**France**  
4 Allee du Cantal  
Evry, Cedex  
France  
33 16079 5900  
fax: 33 16079 8903  
sales.fr@  
bfioptilas.avnet.com

**Holland**  
Chr. Huygensweg 17  
2400 AJ ALPHEN AAN DEN  
RIJN  
The Netherlands  
31 172 446060  
fax: 33 172 443414  
sales.nl@  
bfioptilas.avnet.com

**Spain**  
C/Isobel Colbrand, 6 – 4a  
28050 Madrid  
Spain  
34 913588611  
fax: 34 913589271  
sales.es@  
bfioptilas.avnet.com

**Sales Office Headquarters**

**United States (East Coast)**  
Raytheon  
362 Lowell Street  
Andover, MA 01810  
978-684-8628  
fax: 978-684-8646  
Walter Shelmet  
wshelmet@  
rrfc.raytheon.com

**United States (West Coast)**  
Raytheon  
362 Lowell Street  
Andover, MA 01810  
978-684-8919  
fax: 978-684-8646  
Rob Sinclair  
robert\_w\_sinclair@  
rrfc.raytheon.com

**Europe**  
Raytheon  
AM Teckenberg 53  
40883 Ratingen  
Germany  
49-2102-706-155  
fax: 49-2102-706-156  
Peter Hales  
peter\_j\_hales@  
raytheon.com

**Asia**  
Raytheon  
Room 601, Gook Je Ctr. Bldg  
191 Hangang Ro 2-GA  
Yongsan-Gu, Seoul,  
Korea 140-702  
82-2-796-5797  
fax: 82-2-796-5790  
T.G. Lee  
tg\_lee@  
rrfc.raytheon.com

**Customer Support**

978-684-8900

fax: 978-684-5452

customer\_support@rrfc.raytheon.com