

RMWB11001

11 GHz Buffer Amplifier MMIC

General Description

The RMWB11001 is a 2-stage GaAs MMIC amplifier designed as a 10.5 to 11.7 GHz Buffer Amplifier for use in point to point and point to multi-point radios, and various communications applications. In conjunction with other Fairchild RF amplifiers, multipliers and mixers it forms part of a complete 38 GHz transmit/receive chipset. The RMWB11001 utilizes our 0.25 μ m power PHEMT process and is sufficiently versatile to serve in a variety of medium power amplifier applications.

Features

- 4 mil substrate
- Small-signal gain 21dB (typ.)
- Saturated Power Out 19dBm (typ.)
- Voltage Detector Included to Monitor Pout
- Chip size 2.0mm x 1.3mm

Device

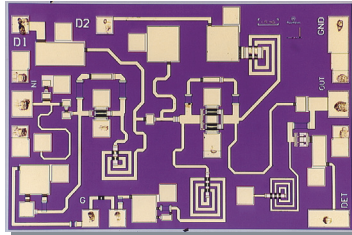

Absolute Ratings

Symbol	Parameter	Ratings	Units
V _d	Positive DC Voltage (+4V Typical)	+6	V
V _g	Negative DC Voltage	-2	V
V _{dg}	Simultaneous (V _d -V _g)	8	V
I _D	Positive DC Current	104	mA
P _{IN}	RF Input Power (from 50 Ω source)	+8	dBm
T _C	Operating Baseplate Temperature	-30 to +85	°C
T _{STG}	Storage Temperature Range	-55 to +125	°C
R _{JC}	Thermal Resistance (Channel to Backside)	180	°C/W

Electrical Characteristics (At 25°C, 50Ω system, Vd = +4V, Quiescent Current (Idq) = 36mA)

Parameter	Min	Typ	Max	Units
Frequency Range	10.5		11.7	GHz
Gate Supply Voltage ¹ (Vg)		-0.5		V
Gain Small Signal (Pin = -10dBm)	18	21		dB
Gain Variation vs. Frequency			0.5	dB
Power Output Saturated: (Pin = 2dBm)	17	19		dBm
Drain Current at Psat (Pin = 2dBm)		55		mA
Power Added Efficiency (PAE): at Psat		35		%
Input Return Loss (Pin = -10dBm)		13		dB
Output Return Loss (Pin = -10dBm)		18		dB
Noise Figure		4		dB
Detector Voltage (Pout = +18dBm)		0.5		V

Note:

1: Typical range of gate voltage is -0.8 to 0.2V to set typical Idq of 36mA.

Functional Block Diagram¹

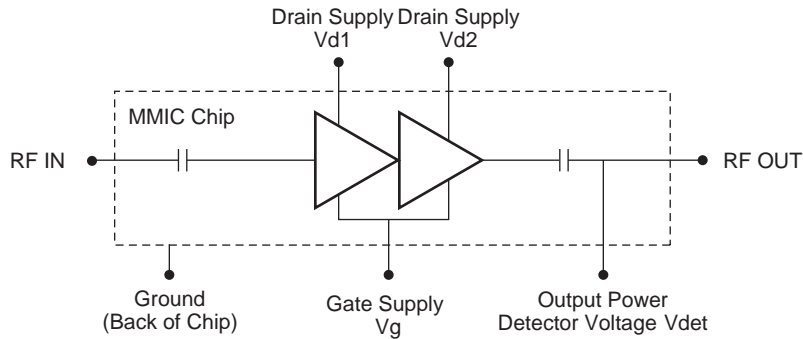

Note:

1: Detector delivers approx. 0.5V DC into 3kΩ load resistor for > +18dBm output power. If output power level detection is not desired, do not make connection to detector bond pad.

Figure 1. Chip Layout and Bond Pad Locations

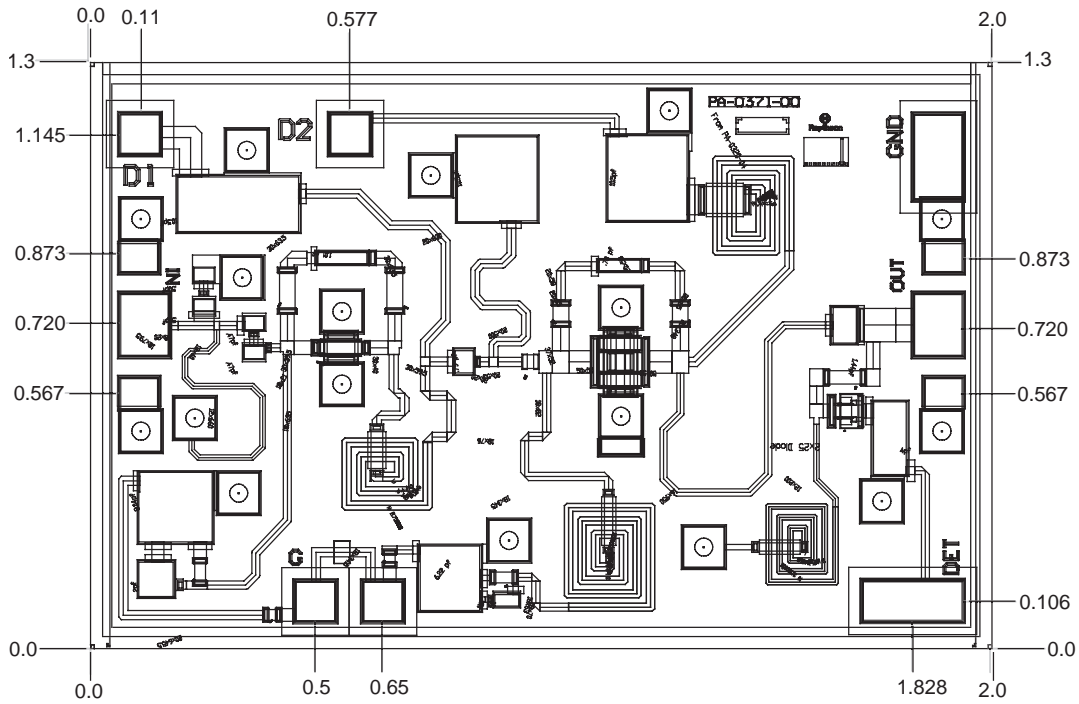

Chip Size is 2.0mm x 1.3mm X 100µm. Back of chip is RF and DC Ground.

Figure 2. Recommended Application Schematic Circuit Diagram

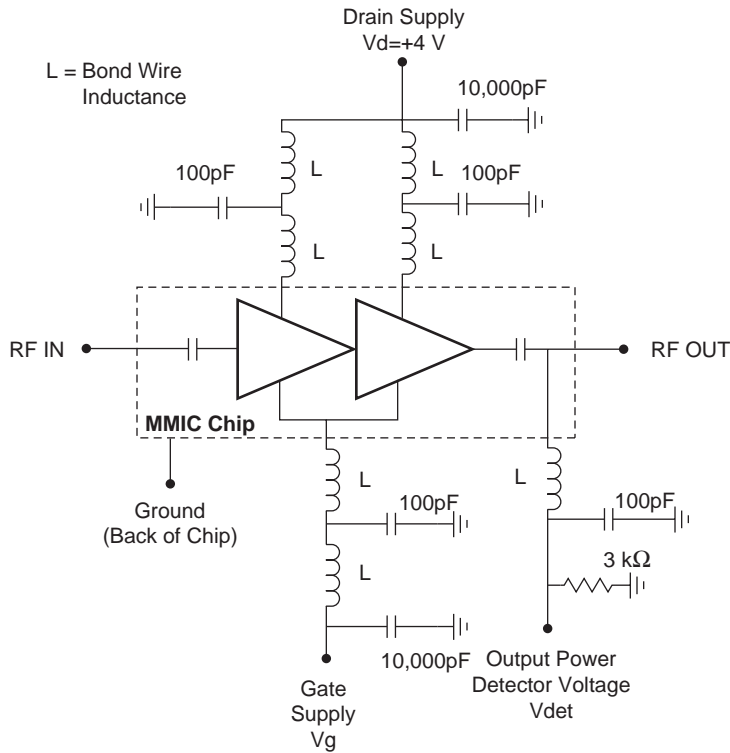

Note : Detector delivers approx. 0.5V DC into 3kΩ load resistor for >+18 dBm output power. If output power level detection is not desired, do not make connection to detector bond pad.

Figure 3. Recommended Assembly Diagram

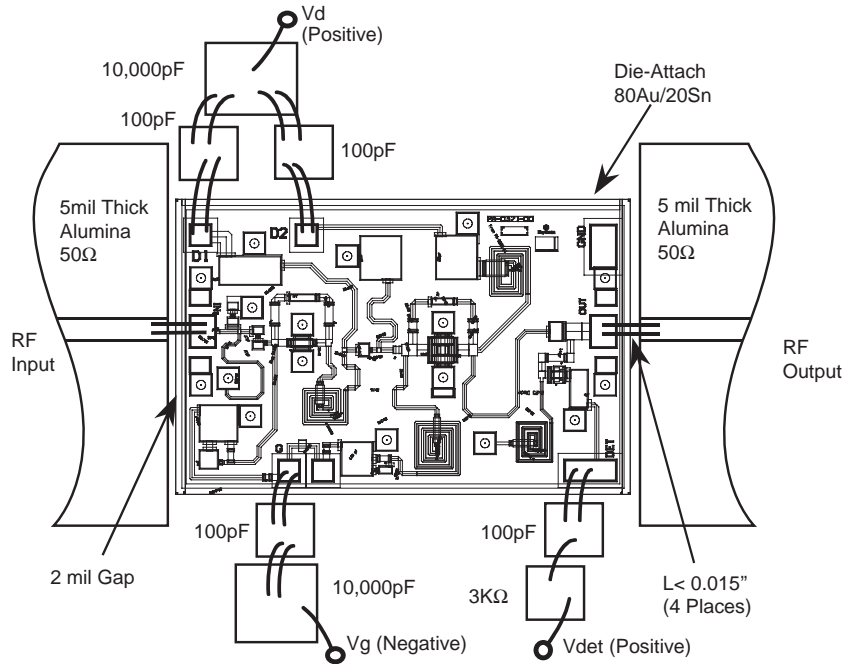

Notes:

Use 0.003" by 0.0005" Gold Ribbon for bonding. RF input and output bonds should be less than 0.015" long with stress relief. Detector delivers approx. 0.5V DC into 3 kΩ load resistor for >+18 dBm output power. If output power level detection is not desired do not make connection to detector bond pad.

Application Information

CAUTION: THIS IS AN ESD SENSITIVE DEVICE.

Chip carrier material should be selected to have GaAs compatible thermal coefficient of expansion and high thermal conductivity such as copper molybdenum or copper tungsten. The chip carrier should be machined, finished flat, plated with gold over nickel and should be capable of withstanding 325°C for 15 minutes.

Die attachment should utilize Gold/Tin (80/20) eutectic alloy solder and should avoid hydrogen environment for PHEMT devices. Note that the backside of the chip is gold plated and is used as RF and DC ground.

These GaAs devices should be handled with care and stored in dry nitrogen environment to prevent contamination of bonding surfaces. These are ESD sensitive devices and should be handled with appropriate precaution including the use of wrist grounding straps. All die attach and wire/ribbon bond equipment must be well grounded to prevent static discharges through the device.

Recommended wire bonding uses 3 mils wide and 0.5 mil thick gold ribbon with lengths as short as practical allowing for appropriate stress relief. The RF input and output bonds should be typically 0.012" long corresponding to a typical 2 mil gap between the chip and the substrate material.

Recommended Procedure for Biasing and Operation

CAUTION: LOSS OF GATE VOLTAGE (Vg) WHILE DRAIN VOLTAGE (Vd) IS PRESENT MAY DAMAGE THE AMPLIFIER CHIP.

The following sequence of steps must be followed to properly test the amplifier:

- Step 1:** Turn off RF input power.
- Step 2:** Connect the DC supply grounds to the ground of the chip carrier. Slowly apply negative gate bias supply voltage of -1.5V to Vg.

- Step 3:** Slowly apply positive drain bias supply voltage of +4V to Vd.
- Step 4:** Adjust gate bias voltage to set the quiescent current of Idq = 36mA.
- Step 5:** After the bias condition is established, the RF input signal may now be applied at the appropriate frequency band.
- Step 6:** Follow turn-off sequence of:
 - (i) Turn off RF input power,
 - (ii) Turn down and off drain voltage (Vd),
 - (iii) Turn down and off gate bias voltage (Vg).

Performance Data

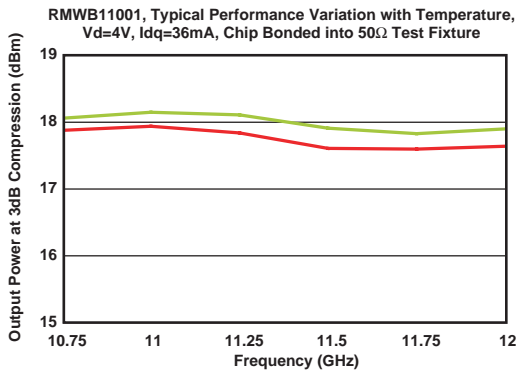
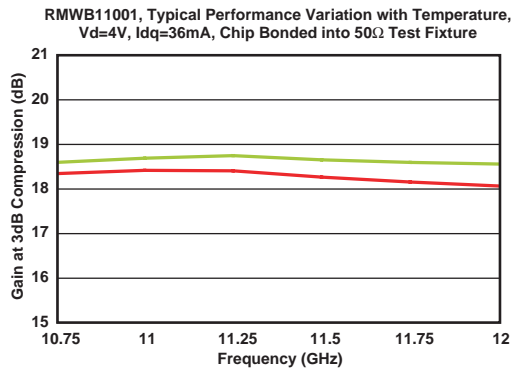
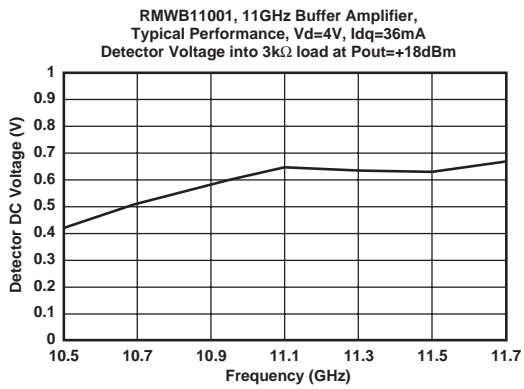
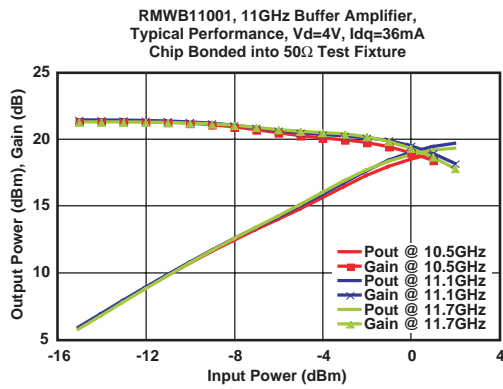
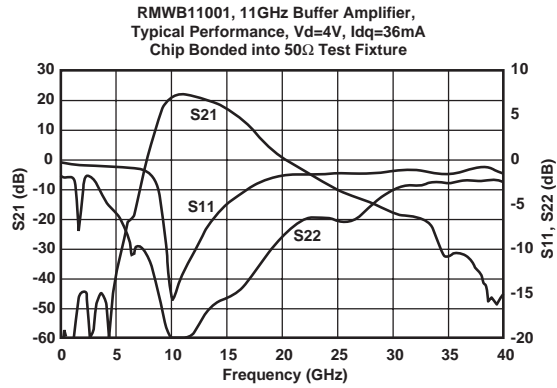
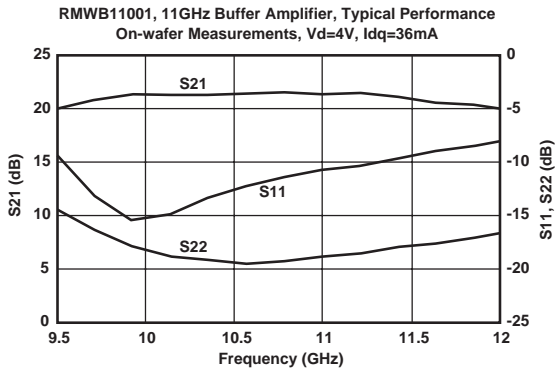

TRADEMARKS

The following are registered and unregistered trademarks Fairchild Semiconductor owns or is authorized to use and is not intended to be an exhaustive list of all such trademarks.

ACEx™	FAST®	ISOPLANAR™	Power247™	SuperFET™
ActiveArray™	FASTr™	LittleFET™	PowerSaver™	SuperSOT™-3
Bottomless™	FPST™	MICROCOUPLER™	PowerTrench®	SuperSOT™-6
CoolFET™	FRFET™	MicroFET™	QFET®	SuperSOT™-8
CROSSVOLT™	GlobalOptoisolator™	MicroPak™	QS™	SyncFET™
DOMET™	GTO™	MICROWIRE™	QT Optoelectronics™	TinyLogic®
EcoSPARK™	HiSeC™	MSX™	Quiet Series™	TINYOPTO™
E ² C MOS™	ꞑC™	MSXPro™	RapidConfigure™	TruTranslation™
EnSigna™	i-Lo™	OCX™	RapidConnect™	UHC™
FACT™	ImpliedDisconnect™	OCXPro™	µSerDes™	UltraFET®
FACT Quiet Series™		OPTOLOGIC®	SILENT SWITCHER®	VCX™
Across the board. Around the world.™		OPTOPLANAR™	SMART START™	
The Power Franchise®		PACMAN™	SPM™	
Programmable Active Droop™		POP™	Stealth™	

DISCLAIMER

FAIRCHILD SEMICONDUCTOR RESERVES THE RIGHT TO MAKE CHANGES WITHOUT FURTHER NOTICE TO ANY PRODUCTS HEREIN TO IMPROVE RELIABILITY, FUNCTION OR DESIGN. FAIRCHILD DOES NOT ASSUME ANY LIABILITY ARISING OUT OF THE APPLICATION OR USE OF ANY PRODUCT OR CIRCUIT DESCRIBED HEREIN; NEITHER DOES IT CONVEY ANY LICENSE UNDER ITS PATENT RIGHTS, NOR THE RIGHTS OF OTHERS.

LIFE SUPPORT POLICY

FAIRCHILD'S PRODUCTS ARE NOT AUTHORIZED FOR USE AS CRITICAL COMPONENTS IN LIFE SUPPORT DEVICES OR SYSTEMS WITHOUT THE EXPRESS WRITTEN APPROVAL OF FAIRCHILD SEMICONDUCTOR CORPORATION. As used herein:

1. Life support devices or systems are devices or systems which, (a) are intended for surgical implant into the body, or (b) support or sustain life, or (c) whose failure to perform when properly used in accordance with instructions for use provided in the labeling, can be reasonably expected to result in significant injury to the user.
2. A critical component is any component of a life support device or system whose failure to perform can be reasonably expected to cause the failure of the life support device or system, or to affect its safety or effectiveness.

PRODUCT STATUS DEFINITIONS

Definition of Terms

Datasheet Identification	Product Status	Definition
Advance Information	Formative or In Design	This datasheet contains the design specifications for product development. Specifications may change in any manner without notice.
Preliminary	First Production	This datasheet contains preliminary data, and supplementary data will be published at a later date. Fairchild Semiconductor reserves the right to make changes at any time without notice in order to improve design.
No Identification Needed	Full Production	This datasheet contains final specifications. Fairchild Semiconductor reserves the right to make changes at any time without notice in order to improve design.
Obsolete	Not In Production	This datasheet contains specifications on a product that has been discontinued by Fairchild semiconductor. The datasheet is printed for reference information only.

Rev. I11