

120mA 6-Channel Charge Pump White LED Driver with Low Dropout Current Source

General Description

The RP1366 is a high performance white LED driver. It integrates a current sources and automatic mode selection charge pump. The part maintains the high efficiency by utilizing an x1/x1.5 fractional charge pump and low dropout current sources. The small equivalent x1 mode open loop resistance and ultra-low dropout voltage of current source extend the operating time of x1 mode and optimize the efficiency of Li-ion battery in white LED applications.

The RP1366 supports up to 6 white LEDs and regulates a constant current for uniform intensity. The part implements a 4-bit DAC for brightness control. Users can easily configure the LED current from 1.25mA to 20mA by a serial pulse. The dimming of white LEDs current can be achieved by applying a pulse signal to the EN pin. There are totally 16 steps of current could be set by users. The operating voltage range is 2.8V to 5V. Internal soft start circuitry effectively reduces the in-rush current while both start-up and mode transition. The load is disconnected from V_{IN} while shutdown and the shutdown current is less than 1uA.

The RP1366 is available in a WQFN 3x3-16L package.

Ordering Information

RP1366	□	□	
		Package Type	
		QW : WQFN-16L 3x3 (W-Type)	
		Operating Temperature Range	
		G : Green (Halogen Free with Commercial Standard)	

Note :

Richpower Green products are :

- ▶ RoHS compliant and compatible with the current requirements of IPC/JEDEC J-STD-020.
- ▶ Suitable for use in SnPb or Pb-free soldering processes.

Marking Information

For marking information, contact our sales representative directly or through a Richpower distributor located in your area, otherwise visit our website for detail.

Features

- 85% Average Efficiency Over Battery Life
- Support up to 6 White LEDs
- 80mV Typical Current Source Dropout
- Support up to 120mA Output Current
- 1% Typical LED Current Accuracy
- 0.7% Typical LED Current Matching
- Soft Start Function
- Auto Charge Pump Mode Selection
- 1MHz Fixed Frequency Oscillator
- Output Over Voltage Protection
- 16-Step Brightness Control
- Low Input Noise and EMI
- Low 0.3uA Shutdown Current
- RoHS Compliant and Halogen Free

Applications

- Mobile Phone, DSC, MP3
- White LED Backlighting
- LCD Display Supply

Pin Configurations

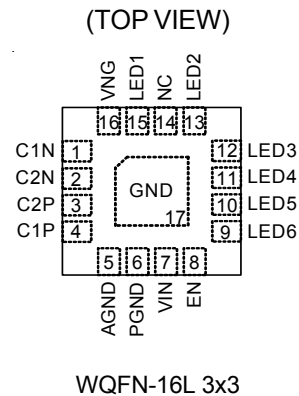

Typical Application Circuit

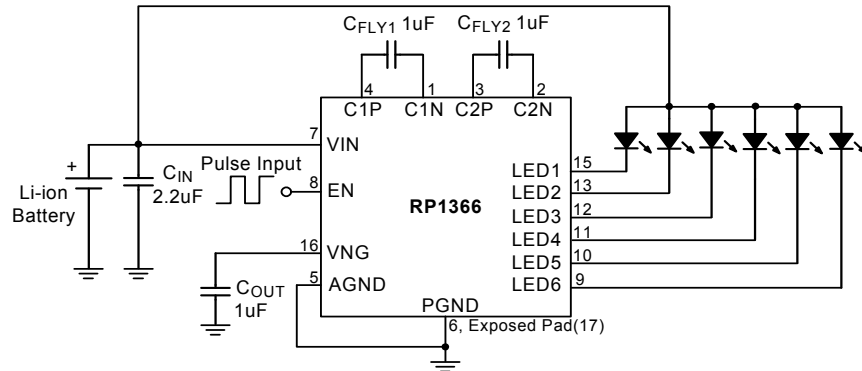

Figure 1. For 6-WLEDs Application Circuit

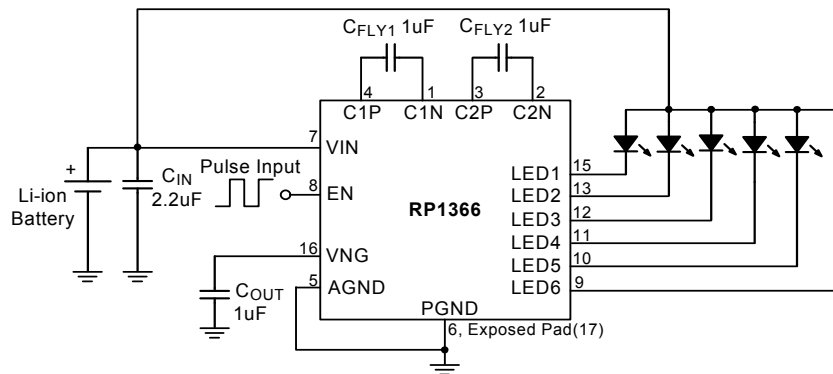

Figure 2. For 5-WLEDs Application Circuit

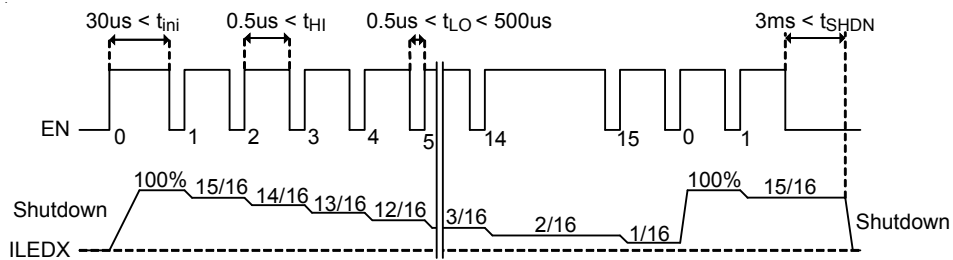
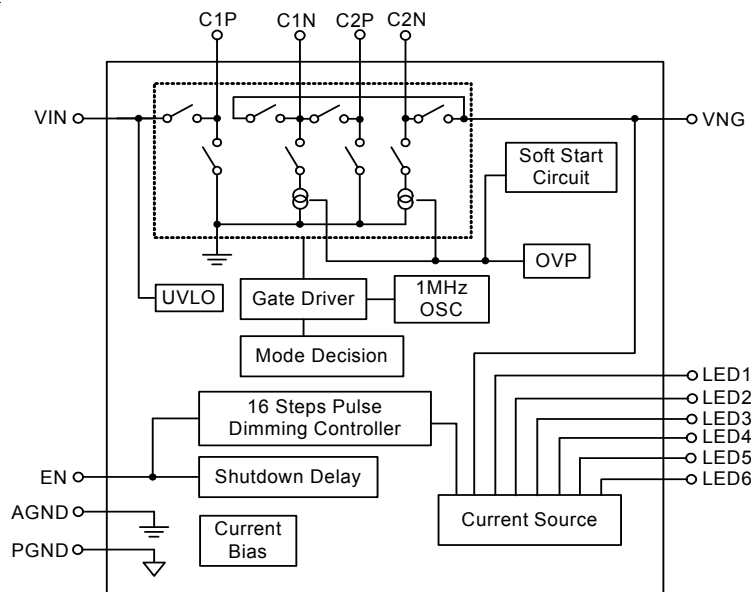

Figure 3. Brightness Control by Pulse Dimming

Functional Pin Description

Pin No.	Pin Name	Pin Function
1	C1N	Negative Terminal of Bucket Capacitor 1.
2	C2N	Negative Terminal of Bucket Capacitor 2.
3	C2P	Positive Terminal of Bucket Capacitor 2.
4	C1P	Positive Terminal of Bucket Capacitor 1.
5	AGND	Analog Ground.
6	PGND	Power Ground.
7	VIN	Supply Input Voltage.
8	EN	Chip Enable (Active High), and this pin should be connected to GPIO pin of MCU.
9	LED6	Current Sink for LED6. (If not in use, the pin should be connected to VIN)
10	LED5	Current Sink for LED5. (If not in use, the pin should be connected to VIN)
11	LED4	Current Sink for LED4. (If not in use, the pin should be connected to VIN)
12	LED3	Current Sink for LED3. (If not in use, the pin should be connected to VIN)
13	LED2	Current Sink for LED2. (If not in use, the pin should be connected to VIN)
15	LED1	Current Sink for LED1. (If not in use, the pin should be connected to VIN)
14	NC	No Internal Connection.
16	VNG	Charge Pump Output.
17 (Exposed Pad)	GND	The exposed pad must be soldered to a large PCB and connected to GND for maximum power dissipation.

Function Block Diagram



Absolute Maximum Ratings (Note 1)

- Supply Input Voltage, V_{IN} ----- -0.3V to 6V
- Other I/O Pin Voltage ----- -0.3V to 6V
- Power Dissipation, $P_D @ T_A = 25^\circ C$
 WQFN-16L 3x3 ----- 1.47W
- Package Thermal Resistance (Note 4)
 WQFN-16L 3x3, θ_{JA} ----- $68^\circ C/W$
- Junction Temperature ----- $150^\circ C$
- Lead Temperature (Soldering, 10 sec.) ----- $260^\circ C$
- Storage Temperature Range ----- $-40^\circ C$ to $150^\circ C$
- ESD Susceptibility (Note 2)
 HBM (Human Body Mode) ----- 2kV
 MM (Machine Mode) ----- 200V

Recommended Operating Conditions (Note 3)

- Junction Temperature Range ----- $-40^\circ C$ to $125^\circ C$
- Ambient Temperature Range ----- $-40^\circ C$ to $85^\circ C$

Electrical Characteristics

($V_{IN} = 3.6V$, $V_F = 3.4V$, $C_{IN} = 2.2\mu F$, $C_{OUT} = C_{FLY} = \mu F$ (ESR = $30m\Omega$), $I_{LED1\ to\ 6} = 15mA$, $T_A = 25^\circ C$, unless otherwise

Specification) Parameter	Symbol	Test Condition	Min	Typ	Max	Units
Input						
Input Supply Voltage	V_{IN}		2.8	–	5	V
Under-Voltage Lockout Threshold	V_{UVLOH}	V_{IN} Rising	--	2.2	--	V
Under-Voltage Lockout Hysteresis			--	200	--	mV
EN Input Current		$V_{EN} = 1.8V$	--	1	--	μA
Quiescent of x1 Mode	$I_{Q\ x1}$	x1 Mode, $V_{IN} = 5.5V$, LED off	--	1	--	mA
Shutdown Current	I_{SHDN}	$V_{EN} = 0V$, $V_{IN} = 5.5V$	--	0.4	1	μA
Output						
x1 Mode to x1.5 Mode Transition Voltage	V_{TRAN}	$V_{LED} = 3.4V$, $I_{LED1\ to\ 6} = 15mA$	--	3.5	--	V
Mode Transition Hysteresis			--	300	--	mV
I_{LEDx} Accuracy	$I_{LED-ERR}$	100% Setting, $I_{LED1\ to\ 6}$	-8	–	+8	%
Current Matching	$I_{LED-LED-ERR}$	100% Setting, $I_{LED1\ to\ 6}$	-5	–	+5	%
Enable						
EN Low Time for Shut Down	T_{SHDN}		3	–	--	ms
EN Low Time for Dimming	T_{LO}		0.5	–	500	μs
EN High Time for Dimming	T_{HI}		0.5	–	--	μs
EN Threshold	Logic-High Voltage	V_{IH}	1.5	–	--	V
	Logic-Low Voltage	V_{IL}	--	–	0.4	V
Frequency						
Oscillator Frequency	f_{OSC}		--	1	--	MHz
Protection						
Over Voltage Protection	V_{OVP}	$V_{IN} - V_{OUT}$	--	5.5	--	V

Note 1. Stresses listed as the above "Absolute Maximum Ratings" may cause permanent damage to the device. These are for stress ratings. Functional operation of the device at these or any other conditions beyond those indicated in the operational sections of the specifications is not implied. Exposure to absolute maximum rating conditions for extended periods may remain possibility to affect device reliability.

Note 2. Devices are ESD sensitive. Handling precaution is highly recommended.

Note 3. The device is not guaranteed to function outside its operating conditions.

Note 4. θ_{JA} is measured in the natural convection at $T_A = 25^\circ\text{C}$ on a low effective thermal conductivity test board of JEDEC 51-3 thermal measurement standard.

Typical Operating Characteristics

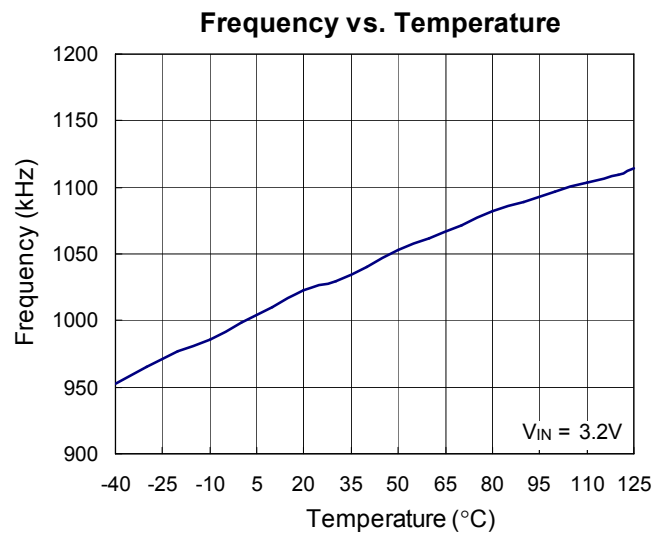
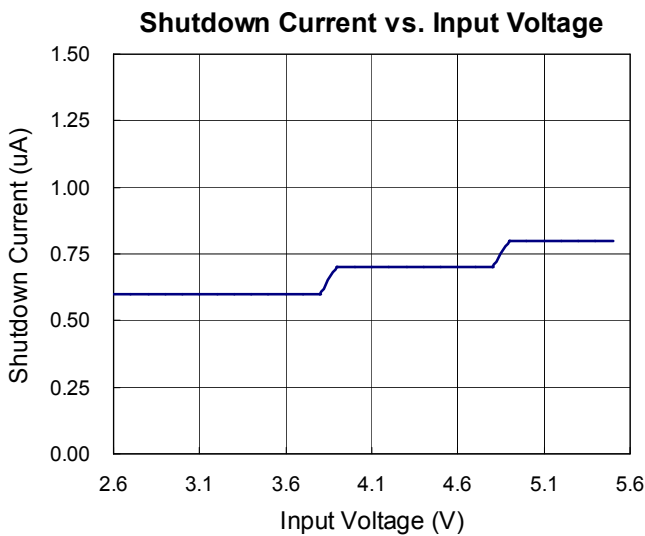
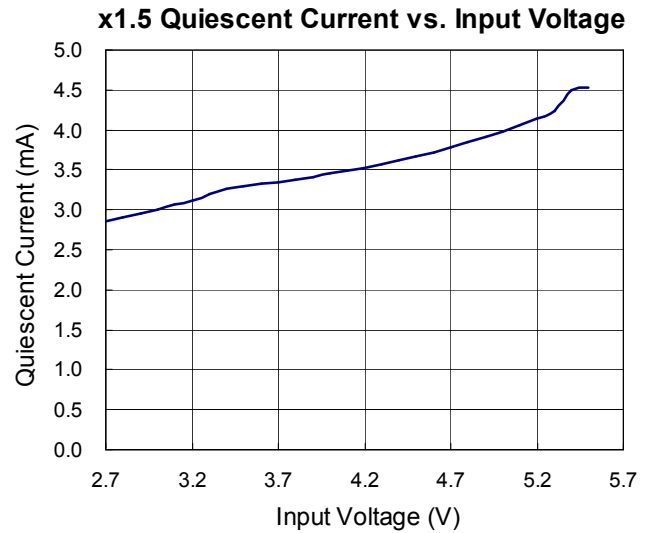
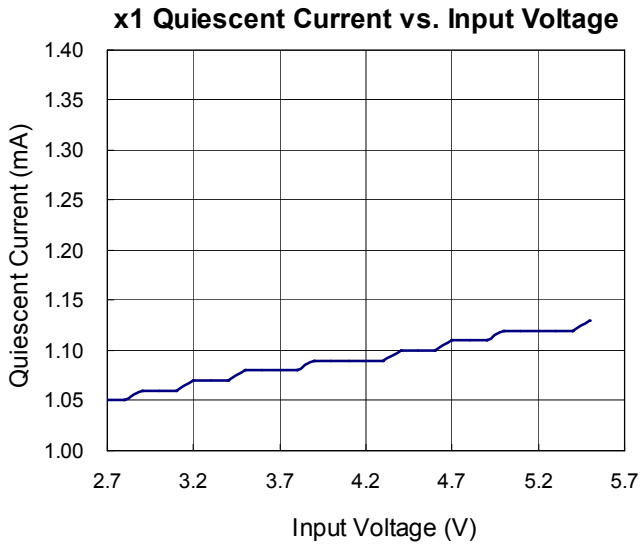
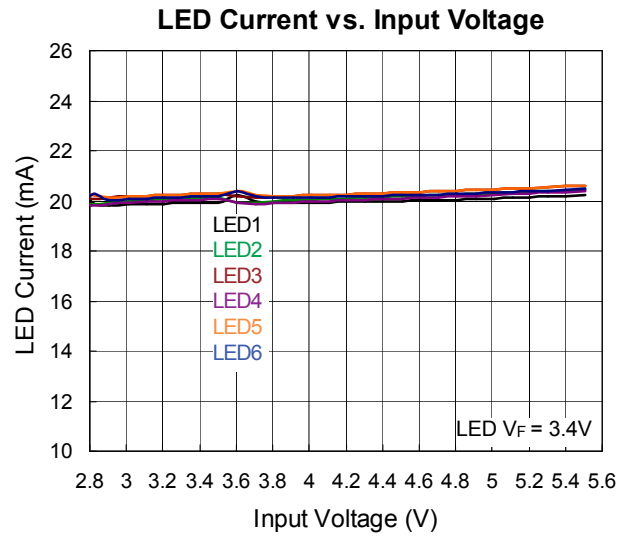
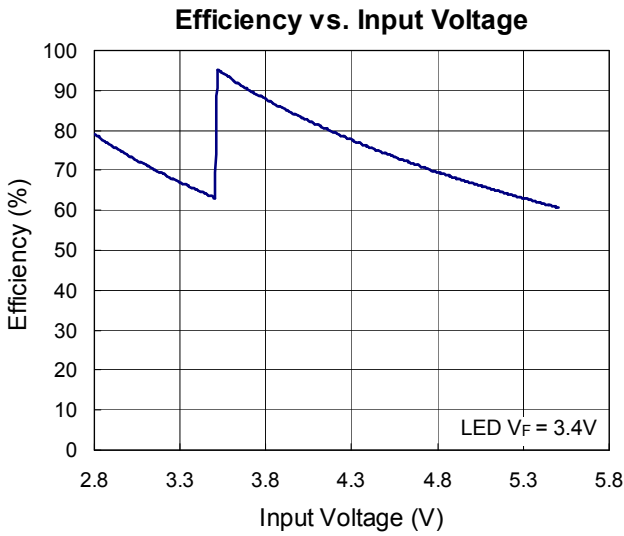

x1 Mode Power On from EN

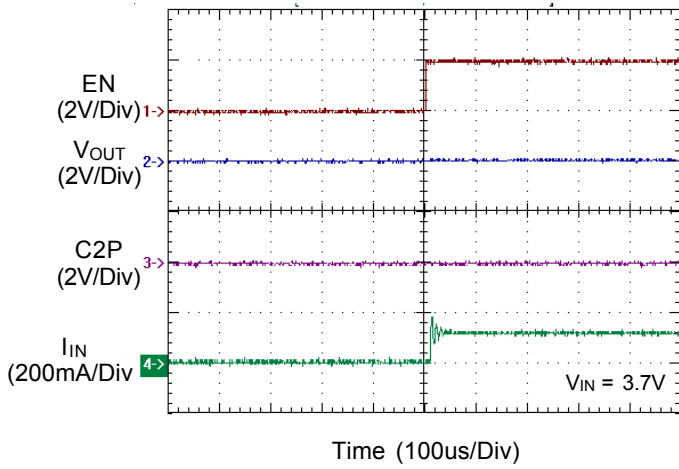

x1.5 Mode Power On from EN

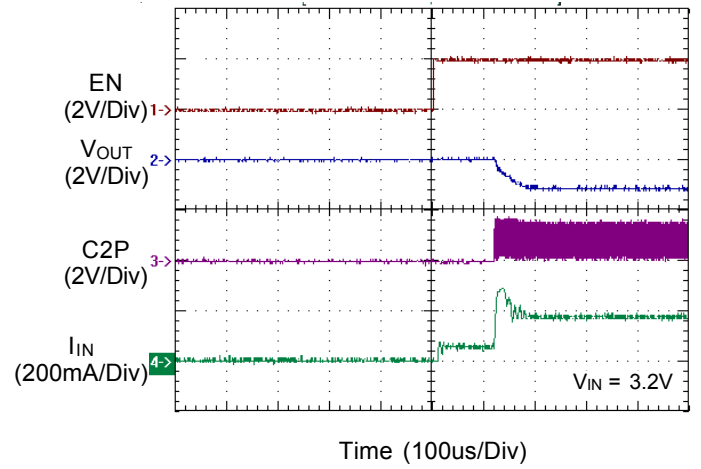

Dimming Operation

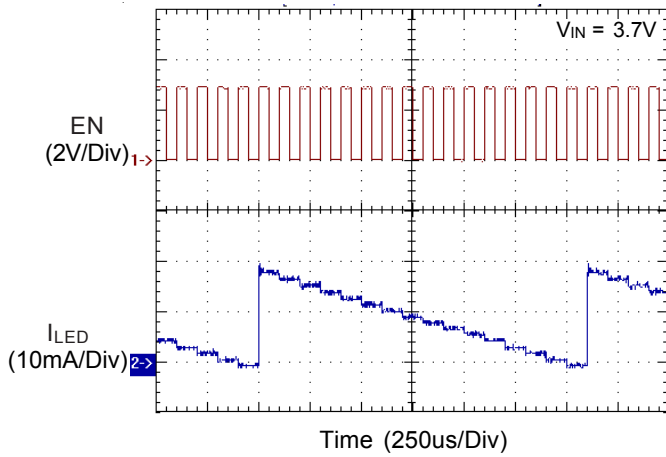

Switching

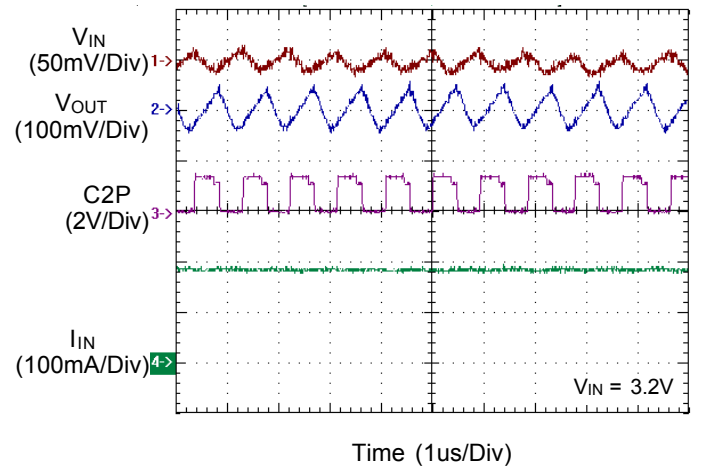

Applications Information

The RP1366 uses a fractional switched capacitor charge pump to power up to six white LEDs with a programmable current for uniform intensity. The part integrates current sources and automatic mode selection charge pump. It maintains the high efficiency by utilizing an x1/x1.5 fractional charge pump and current sources. The small equivalent x1 mode open loop resistance and ultra-low dropout voltage of current source extend the operating time of x1 mode and optimize the efficiency in white LED applications.

Input UVLO

The input operating voltage range of the RP1366 is from 2.8V to 5V. An input capacitor at the VIN pin could reduce the ripple voltage. It is recommended to use a ceramic 2.2 μ F or larger capacitance as the input capacitor. This IC provides an under voltage lockout (UVLO) function to prevent it from unstable issue when startup. The UVLO threshold of input rising voltage is set at 2.2V typically with a hysteresis of 0.2V.

Soft Start

The RP1366 employs a soft start feature to limit the inrush current. The soft-start circuit prevents the excessive inrush current and input voltage droop. The soft-start clamps the input current over a typical period of 50 μ s.

Mode Decision

The RP1366 uses a smart mode selection method to decide the working mode for optimizing the efficiency. Mode decision circuit senses the output and LED voltage for up/down selection. The RP1366 automatically switches to x1.5 mode whenever the dropout condition is detected from the current source and returns to x1 mode whenever the dropout condition releases.

LED connection

The RP1366 supports up to 6 white LEDs. The six LEDs are connected from VIN to pin 9, 10, 11, 12, 13, and 15 respectively. If the LED is not used, the LED pin should be connected to VIN directly. Figure 2 shows the connection for 5-WLEDs application, pin 9 is connected to VIN.

Selecting Capacitors

To get the better performance of the RP1366, the selection of peripherally appropriate capacitor and value is very important. These capacitors determine some parameters such as input/output ripple voltage, power efficiency and maximum supply current by charge pump. To reduce the input and output ripple effectively, the low ESR ceramic capacitors are recommended. For LED driver applications, the input voltage ripple is more important than the output ripple. Input ripple is controlled by the input capacitor C_{IN} , increasing the value of input capacitance can further reduce the ripple. Practically, the input voltage ripple depends on the power supply impedance. The flying capacitor C_{FLY1} and C_{FLY2} determine the supply current capability of the charge pump to influence the overall efficiency of the system. The lower value will improve efficiency. However, it will limit the LED's current at low input voltage. For 6 X 20mA load over the entire input range of 2.8V to 5V, it is recommended to use a 1 μ F ceramic capacitor on the flying capacitor C_{FLY1} and C_{FLY2} .

Brightness Control

The RP1366 implements a pulse dimming method to control the brightness of white LEDs. Users can easily configure the LED current from 1.25mA to 20mA by a serial pulse. The dimming of white LEDs' current can be achieved by applying a pulse signal to the EN pin. There are totally 16 steps of current could be set by users. The detailed operation of the brightness dimming is shown in the Figure 3.

Over Voltage Protection

The RP1366 equips over voltage protection function. When LED is open, the voltage between input and output will be clamped at a certain voltage level.

Layout Consideration

The RP1366 is a high-frequency switched-capacitor converter. so, careful PCB layout is necessary. For best performance, place all peripheral components as close to the IC as possible. Place C_{IN} , C_{OUT} , C_{FLY1} and C_{FLY2} near to VIN, VNG, C1P, C1N, C2P, C2N, and GND pin respectively. A short connection is highly recommended.

The following guidelines should be strictly followed for the layout of the RP1366.

1. The exposed pad, GND must be soldered to a large ground plane for heat sinking and noise prevention. The through-hole vias located at the exposed pad are connected to ground plane of the internal layer.
2. VIN traces should be wide enough to minimize inductance and handle the high currents. The trace running from battery to chip should be placed carefully and shielded strictly.
3. Input and output capacitors must be placed close to the part. The connection between pins and capacitor pads should be copper traces without any through-hole via connection.
4. The flying capacitors must be placed close to the part. The traces running from the pins to the capacitor pads should be as wide as possible. Long traces will also produce large noise radiation caused by the large dv/dt on these pins. Short trace is recommended.
5. All the traces of LED and VIN running from pins to LCM module should be shielded and isolated by ground plane. The shielding prevents the interference of high frequency noise coupled from the charge pump.
6. Output capacitor must be placed near VNG pin to reduce noise coupling from charge pump to LEDs.

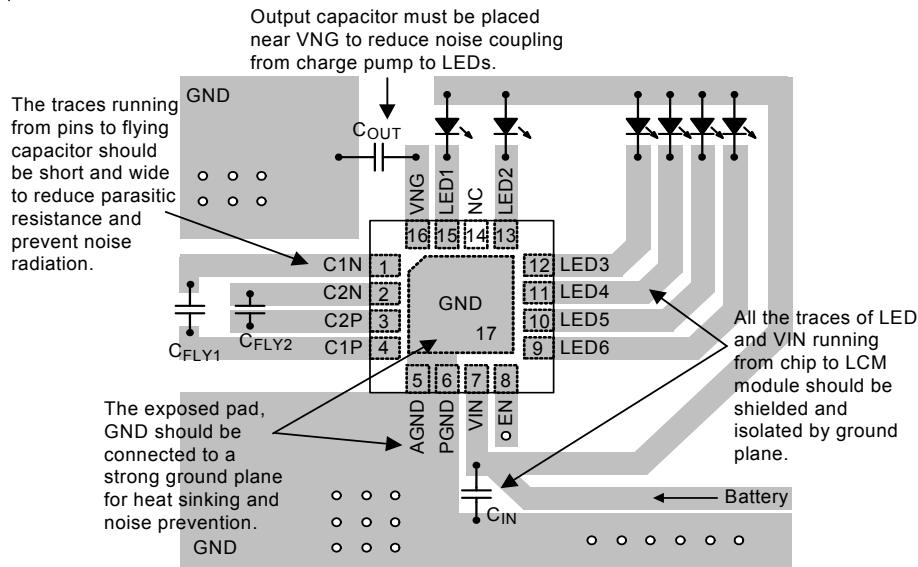
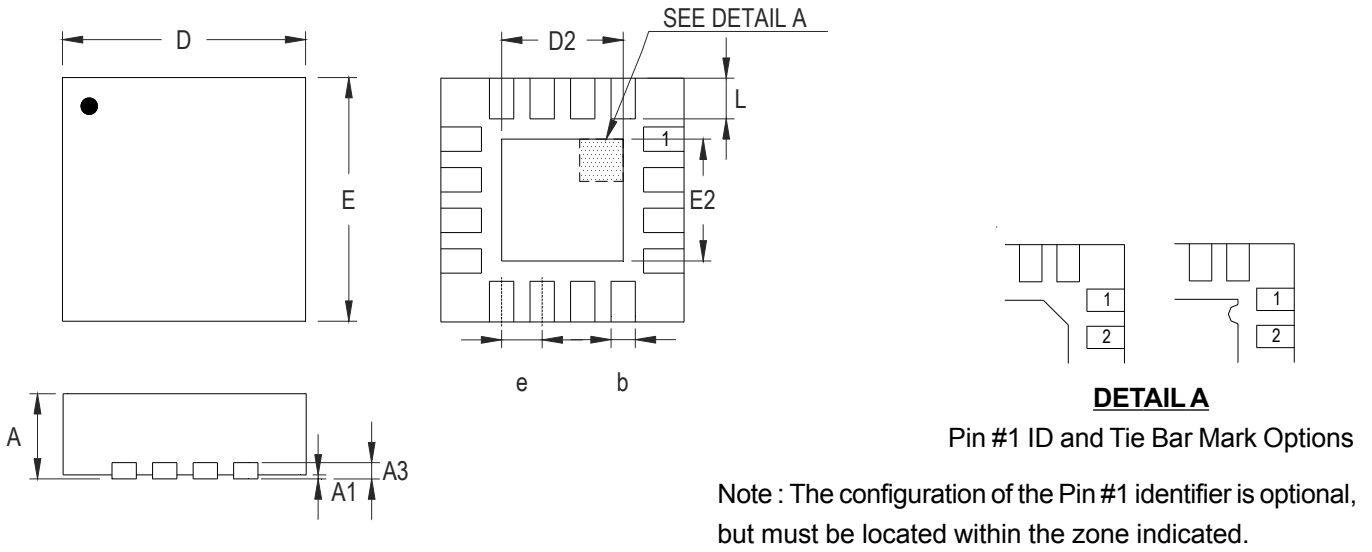

Figure 4

Outline Dimension



Symbol	Dimensions In Millimeters		Dimensions In Inches	
	Min	Max	Min	Max
A	0.700	0.800	0.028	0.031
A1	0.000	0.050	0.000	0.002
A3	0.175	0.250	0.007	0.010
b	0.180	0.300	0.007	0.012
D	2.950	3.050	0.116	0.120
D2	1.300	1.750	0.051	0.069
E	2.950	3.050	0.116	0.120
E2	1.300	1.750	0.051	0.069
e	0.500		0.020	
L	0.350	0.450	0.014	0.018

W-Type 16L QFN 3x3 Package

RICHPower MICROELECTRONICS CORP.

Headquarter

Room 2102, 1077 ZuChongZhi Road, Zhang Jiang Hi-TechPark, Pudong New Area, Shanghai, China

Tel: (8621)50277077 Fax: (8621)50276966

Information that is provided by Richpower Technology Corporation is believed to be accurate and reliable. Richpower reserves the right to make any change in circuit design, specification or other related things if necessary without notice at any time. No third party intellectual property infringement of the applications should be guaranteed by users when integrating Richpower products into any application. No legal responsibility for any said applications is assumed by Richpower.