

## 24 Volt Motors

Year		1985/86	1987	1988	1989-92	1994	1995-97	1998	1999
Manufacturer		Plymouth Rubber Band #33	Canon	TRW/ Globe	HP/ Buhler	HP/ Buhler	HP/ Mabuchi	HP/ Mabuchi	HP/ Mabuchi
Type			DC/PM	DC/PM	DC/PM	DC/PM	DC/PM	DC/PM	DC/PM
Model Number			CN22	403A6	Brush	Brush	Brush	Brush	Brush
					3140-0812/ 1.13.041.006	1645-60170/ 1.13.043.230	C2162-60006/ DN505728	RS-555SB -19160	RS-385SH -16120
Rating	[volts]		24	24	19.1	19.1	19.0	15.0	24.0
Test	[volts]		24	24	19.1	19.1	24.0	24.0	24.0
Stall Current	[amps]			1.5	1.26	2.0	2.5	1.6	2.52
Stall Torque	[N-cm]		0.28	5.65	4.86	18.4	28.7	9.4	4.75
Stall Torque	[in-oz]		0.40	8.00	6.88	26.1	40.6	13.3	6.7
No Load Speed	[rpm]		3,000	2,750	4,550	1,950	4,550	3,540	11,000
No Load Speed	[rad/sec]		314	288	476	204	476	371	1,152
Max. Power	[Watts]		0.22	4.07	5.79	9.4	34.2	8.72	13.7
Max. Power	[milli-hp]		0.29	5.46	7.76	12.6	45.8	11.7	18.2
Duration	[sec]		15.0	30.0	30.0	30.0	30.0	30.0	30.0
Energy	[Joules]	20.0	3.3	122	173	282	1,026	262	411
Weight	[grams]	0.5	47.2	240	172	417	224	220	70
Weight	[oz]	0.018	1.7	8.5	6.0	14.72	7.9	7.76	2.47
Power/Weight	[Watts/kg]		4.66	17.0	33.7	22.5	153	39.6	195.7
Energy/Weight	[Joules/kg]	40,000	69.9	509	1,006	676	4,580	1,191	5,871

## 24 Volt Motors, Continued

Year		1989-92	1994	1995-97	1998	1999
Manufacturer		HP/ Buhler	HP/ Buhler	HP/ Mabuchi	HP/ Mabuchi	HP/ Mabuchi
Type		DC/PM Brush	DC/PM Brush	DC/PM Brush	DC/PM Brush	DC/PM Brush
Model Number		3140-0812/ 1.13.041.006	1645-60170/ 1.13.043.230	C2162-60006/ DN505728	RS-555SB -19160	RS-385SH -16120
No Load Current	[Amps]	0.04	0.07	0.15	0.10	0.085
Start Up Voltage	[Volts]	1.5	1.5	2.0	3.0	1.5
Resistance	[Ohms]	15.2	9.6	8.2	11.6	6.3
Elect. Time Const	[msec]	0.5	1.2		0.9	
Mech. Time Const	[msec]	14.0	7.1		16.0	
Motor Constant	$[N\text{-cm}/\sqrt{Watt}]$	1.2	3.0	1.8	1.78	0.75
Torque Constant	[N-cm/Amp]	4.87	9.3	4.8	6.08	1.9
Voltage Constant	[V/Krpm]	5.1	0.1		6.4	2.0
Inertia	$[g\text{-cm}^2]$	16.0	67.8	45.0	50	8.0
Shaft Diameter	[mm]	3.0	3.96	3.1	3.32	2.3
Shaft Diameter	[in]	0.118	0.156	0.123	0.131	0.091
Shaft Length	[mm]			85.0	85.0	13.8
Motor Diameter	[mm]	30.0	40.0	37.0	37.5	27.7
Motor Length	[mm]	56.5	77.0	64.0	66.0	57.0

## 12 Volt Motors

Year		1994-95,98	1994-99
Manufacturer		GM/ITT	GM/ITT
Type		Clutch DC/PM Brush	No Clutch DC/PM Brush
Model Number			
Rating	[volts]	12	12
Stall Current	[amps]		
Stall Torque	[N-cm]	1.196	1.227
Stall Torque	[in-oz]	1.69	1.73
Max. Speed	[rpm]	4,250	4,050
Max. Speed	[rad/sec]	445.1	424.1
Max. Power	[Watts]	1.33	1.30
Max. Power	[milli-hp]	1.78	1.74
Duration	[sec]	30.0	30.0
Energy	[Joules]	39.9	39.0
Weight	[grams]	45.4	41.0
Weight	[oz]	1.6	1.4
Power/Weight	[Watts/kg]	29.3	31.7
Energy/Weight	[Joules/kg]	878.9	951.2

# Mabuchi RS-385SH-16120

両回転または逆回転でご使用の場合は、端子の位置が異なります。(9ページ参照)  
 The terminal position against the tapped holes varies depending on CW+/NEUTRAL. (Refer to P9)

UNIT: MILLIMETERS

CCW(+)

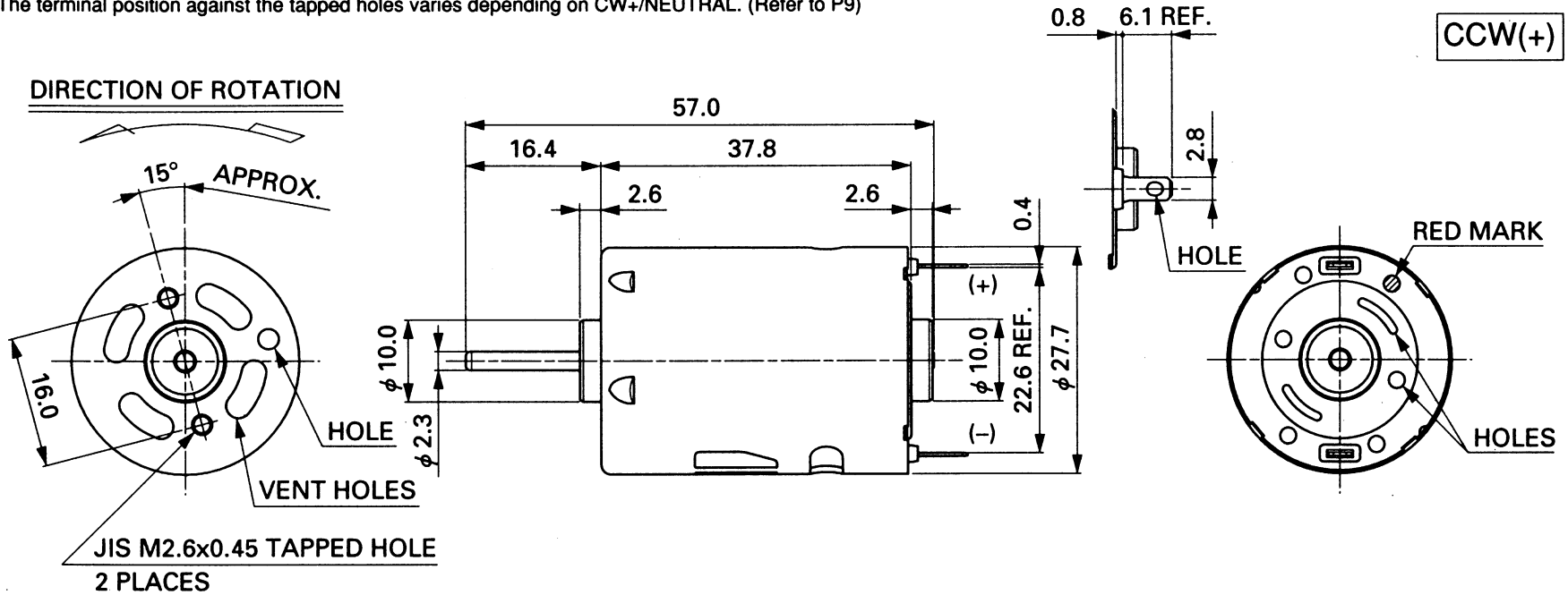

取付けネジはモータケース面より4.0以下  
 Usable male screw length 4.0 max. from motor mounting surface.

WEIGHT: 70g (APPROX)

Mabuchi RS-385SH-16120, Operating at 24.0 Volts

