

RS-385SH



Carbon-brush motors

OUTPUT : 0.9W~35W (APPROX)

WEIGHT : 70g (APPROX)

Typical Applications Home Appliances : Hair Dryer
Precision Instruments : Printer / Copy Machine

MODEL	VOLTAGE		NO LOAD		AT MAXIMUM EFFICIENCY				STALL			
	OPERATING RANGE	NOMINAL	SPEED	CURRENT	SPEED	CURRENT	TORQUE		OUTPUT	TORQUE		CURRENT
			r/min	A	r/min	A	mN-m	g-cm	W	mN-m	g-cm	A
RS-385SH-2270 (*1)	6~24	12V CONSTANT	10000	0.20	8170	0.89	7.89	80.5	6.74	43.2	440	4.00

(*1) CCW shifted commutation (CCW+)

The terminal position against the tapped holes varies depending on CW+/NEUTRAL. (Refer to P19)

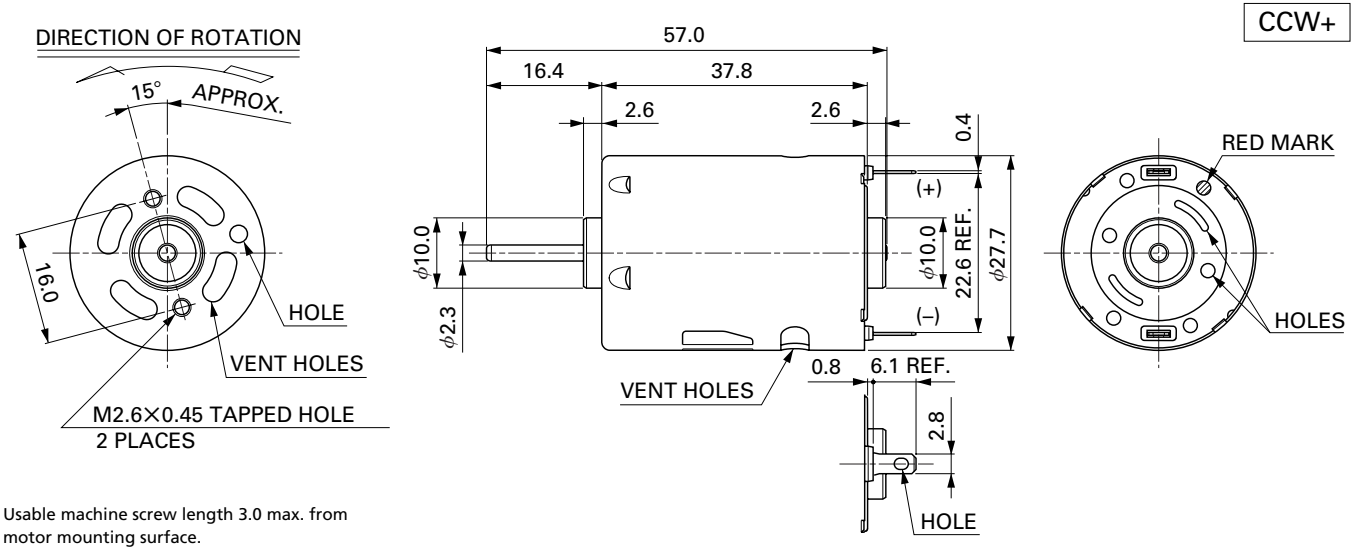

Usable machine screw length 3.0 max. from motor mounting surface.

UNIT: MILLIMETERS

RS-385SH-2270 12.0V

