

输出功率：约4~200W

碳刷马达

典型应用：家用电器

电动玩具

电动工具

OUTPUT:APPROX 4~200W

Cabron-brush Motors

Typical Applications: Household Appliances

Electric Toys

Electrical Tools

1.OUTLINE DRAWING:

UNIT:MM

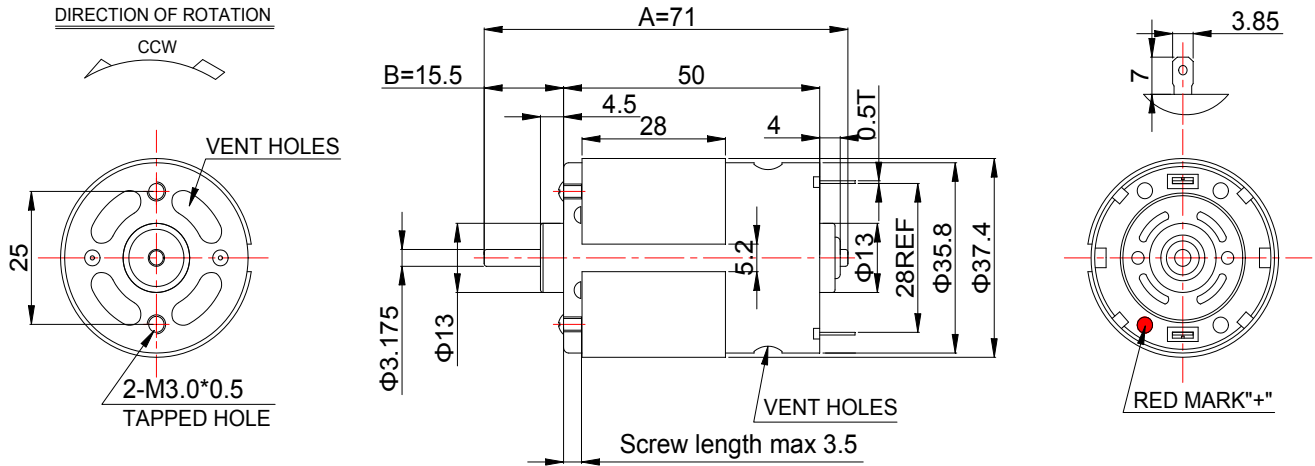

Customizable Parameters:

1. Length A and B
2. Electric Performance
3. Direction of Rotation

WEIGHT: 167g(Approx)

View:

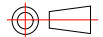

2.MOTOR PERFORMANCE :

MODEL	VOLTAGE		NO LOAD		AT MAXIMUM EFFICIENCY				STALL			
	OPERATING RANGE	NOMINAL	SPEED	CURRENT	SPEED	CURRENT	TORQUE	OUTPUT	TORQUE	CURRENT		
		V	rpm	A	rpm	A	g.cm	mN.m	W	g.cm	mN.m	A
RS-540PH-2962	5.0~13.0	12.0	6450	0.23	5537	1.39	207	20.31	11.76	1460	143.28	8.45
RS-545SH-2190	6.0~25.0	24.0	8500	0.13	7340	0.82	185	18.16	13.93	1355	132.97	5.20
RS-545PH-5025R	5.0~20.0	18.0	25000	1.2	21530	7.44	409	40.14	90.32	2948	289.30	46.20
RS-540PH-7028R	5.0~13.0	12.0	28800	1.75	20270	14.00	550	53.97	114.34	4980	488.71	112.60

