

Damper Diodes (For TV)

Parameter Type No.	Absolute Maximum Ratings					Electrical Characteristics (Ta = 25°C)						Others		
	V _{RM} (V)	I _{F(AV)} (A) () is with Heatsink	I _{FSM} (A) 50Hz Half-cycle Sinewave Single Shot	T _J (°C)	T _{stg} (°C)	V _F (V)		I _R (μA) V _R = V _{RM} max	I _R (H) (μA) V _R = V _{RM} Ta = 100°C max	t _{rr} ① (μs)	t _{rr} ② (μs)	R _{th} (j-ℓ) (°C/W)	Mass (g)	Fig.
						max	I _F (A)							
RS 3FS	1500	2.0	50	-40 to +150		1.1	3.0	50	500	2.0	0.8	10.0	1.0	Ⓐ
RS 4FS		1.5 (2.5)				1.5				1.0				

www.DataSheet4U.com

RS 3FS

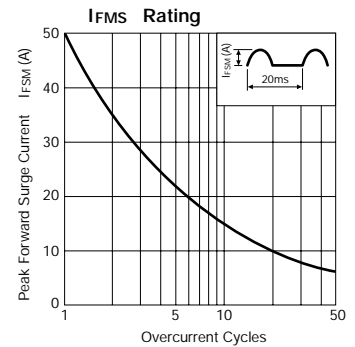
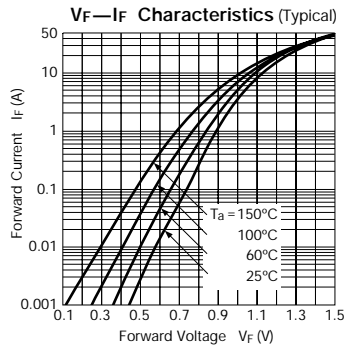
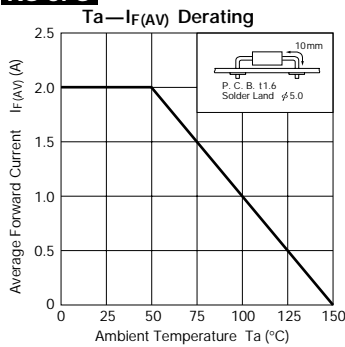

RS 4FS

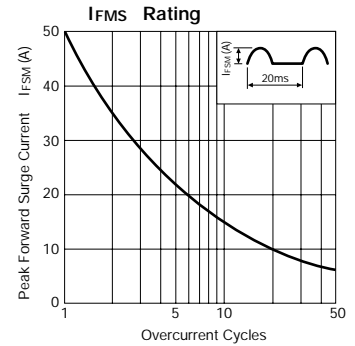
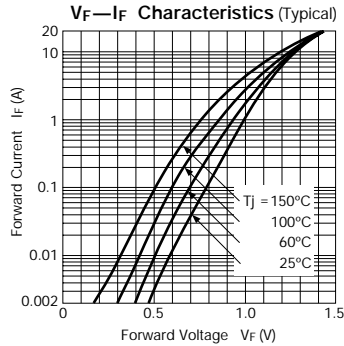
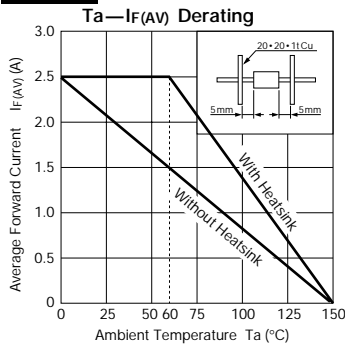

External Dimensions

(Unit: mm) (Full-mold)

Flammability:
UL94V-0 or Equivalent

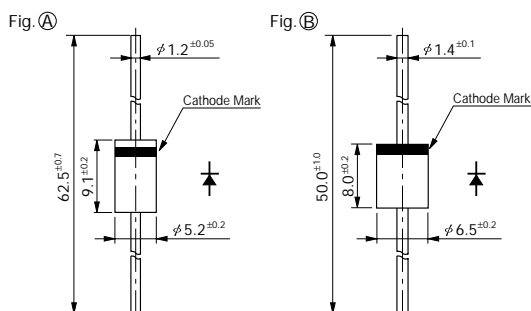

www.DataSheet4U.com