

High Precision Foil Resistor with TCR of ± 2.0 ppm/°C, Tolerance of ± 0.01 % and Load Life Stability of ± 0.005 % CECC Qualified



INTRODUCTION

Bulk Metal® Foil (BMF) technology outperforms all other resistor technologies available today for applications that require high precision and high stability.

This technology has been pioneered and developed by VISHAY, and products based on this technology are the most suitable for a wide range of applications. BMF technology allows us to produce customer orientated products, designed to satisfy challenging and specific technical requirements.

Models RS92N, RS92NA, and AN made from Vishay BMF offers low TCR, excellent load life stability, tight tolerance, fast response time, low current noise, low thermal EMF and low voltage coefficient, all in one resistor.

The RS92N, RS92NA, and AN are virtually insensitive to destabilizing factors. The resistor element is a solid alloy that displays the desirable bulk properties of its parent material, thus it is inherently stable and noise free.

Vishay's Bulk Metal® RS92N, RS92NA, and AN resistors are the modern generation of precision resistors. The standard design of these resistors provides a unique combination of characteristics found in no other single resistor.

Our Application Engineering Department is available to advise and to make recommendations. For non-standard technical requirements and special applications, please contact us.

FEATURES

- Temperature coefficient of resistance (TCR): ± 2 ppm/°C typical (- 55 °C to + 155 °C, ref. + 20 °C)
- Resistance range: 80.6 Ω to 120 k Ω
- Vishay Foil resistors are not restricted to standard values; specific "as required" values can be supplied at no extra cost or delivery (e.g. 1K2345 vs. 1K)
- Rated power: to 0.25 W at + 125 °C
- Tolerance: ± 0.01 %
- Load life stability: to ± 0.005 % at 70 °C, 2000 h at rated power
- Electrostatic discharge up to 25 000 V
- Non inductive, non capacitive design
- Rise time: 1 ns effectively no ringing
- Current noise: < - 40 dB
- Thermal EMF: 0.05 μ V/°C typical
- Voltage coefficient: < 0.1 ppm/V
- Low inductance: < 0.08 μ H typical
- Non hot spot design
- Terminal finish available: tin/lead alloy
- Matched sets are available per request (TCR Tracking: to 0.5 ppm/°C)
- For better TCR and PCR performances please review the [RNC90Z](#) and [Z555](#) datasheets

TABLE 1 - TOLERANCE AND TCR VS. RESISTANCE VALUE (- 55 °C to + 155 °C, + 20 °C Ref.)

RESISTANCE VALUE (Ω)	TOLERANCE (%)	TYPICAL TCR AND MAX. SPREAD (ppm/°C)
80.6 to 120K	± 0.01	$\pm 2 \pm 3$

TABLE 2 - MECHANICAL AND ENVIRONMENTAL SPECIFICATIONS

Mechanical Protection	Insulated case
Resistive Element	Nickel-chromium
Unit Weight	0.3 g
Temperature Limits	- 55 °C to + 155 °C
Climatic Category	55/155/56



TABLE 3 - ELECTRICAL SPECIFICATIONS

Qualified Ohmic Range	RS92N, RS92NA	80R6 to 120K
	AN	80R6 to 92K
Qualified Tolerances		0.01 % to 1 %
Power Rating		0.5 W at +70 °C 0.25 W at + 125 °C
Temperature Coefficient		see diagram
Dielectric Strength		700 V _{AC}
Insulation Resistance		> 10 ⁴ MΩ
Thermal EMF		< 0.5 μV for 1 °C of difference between leads
Noise		non measureable
Thermal Resistance		0.14 °C/mW

TABLE 4 - PERFORMANCE

TESTS	CONDITIONS	REQUIREMENTS C 83-220 CECC 40302-001	TYPICAL DRIFTS
Overload	2.5 U _n /5 s U _{max.} < 2 U _n	± 0.01 %	± 0.002 %
Temperature Cycling	- 55 °C to + 155 °C, 5 cycles CEI 68-2-14 test Na	± 0.01 %	± 0.003 %
Terminals Strength	CEI 68-2-21 test U _a (pulling), U _b (bending), U _c (twisting)	± 0.01 %	± 0.002 %
Resistance to Soldering Heat	260 °C/10 s CEI 68-2-20A test T _b (method 1A)	± 0.01 %	± 0.002 %
Vibrations	10 Hz to 500 Hz 0.75 mm or 10g for 6 h method B4 CEI 68-2-6 test F _c	± 0.01 %	± 0.002 %
Climatic Sequence	- 55 °C to + 155 °C, 6 cycles, 95 % R.H., 85 mbar CEI 68-1	± 0.05 % Insulation R > 10 ² MΩ	± 0.003 % Insulation R > 10 ⁴ MΩ
Humidity (Steady State)	56 days, 95 % R.H., 40 °C CEI 68-2-3	± 0.05 % Insulation R > 10 ² MΩ	± 0.003 % Insulation R > 10 ⁴ MΩ
Load Life	1000 h Pr at + 70 °C 90'/30' cycle	± 0.05 %	± 0.01 %
High Temperature Exposure	1000 h/155 °C CEI 68-2-20A test B	± 0.05 %	± 0.01 %

FIGURE 1 - STANDARD IMPRINTING AND DIMENSIONS

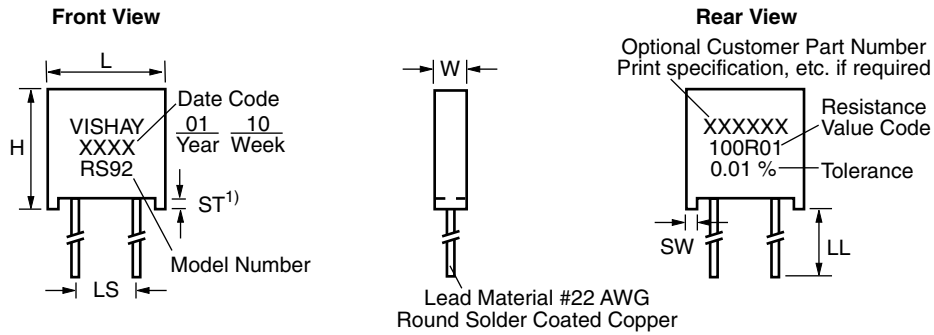

Note

1. The standoffs shall be so located as to give a lead clearance of 0.010" minimum between the resistor body and the printed circuit board when the standoffs are seated on the printed circuit board. This is to allow for proper cleaning of flux and other contaminants from the unit after all soldering processes.

MODEL	DIM.	LS	W	L	H	ST	LL	WEIGHT NOMINAL
RS92NA	mm	3.81 ± 0.13	2.50 max.	7.50 max.	8.00 max.	0.254 min.	25.4 min.	0.6 g
RS92N	mm	5.08 ± 0.076	2.50 max.	7.50 max.	8.00 max.	0.254 min.	25.4 min.	0.6 g
AN	mm	5.08 ± 0.076	2.50 max.	7.50 max.	8.00 max.	0.254 min.	25.4 min.	0.6 g

FIGURE 2 - TRIMMING TO VALUES (Conceptual Illustration)

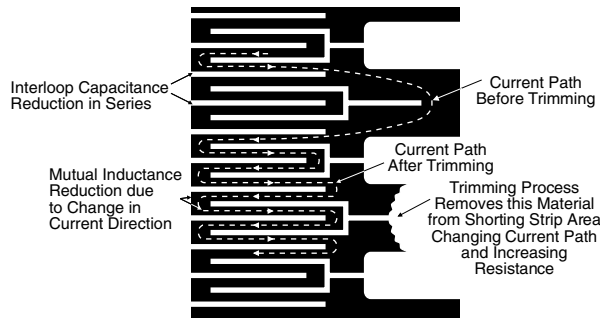

Note: Foil shown in black, etched spaces in white

FIGURE 3 - POWER DERATING CURVE

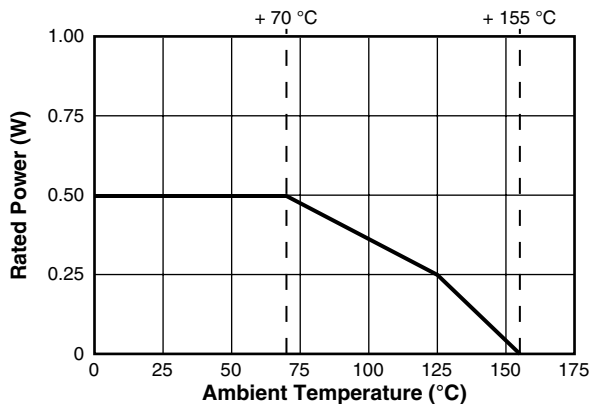

FIGURE 4 - TYPICAL RESISTANCE/TEMPERATURE CURVE

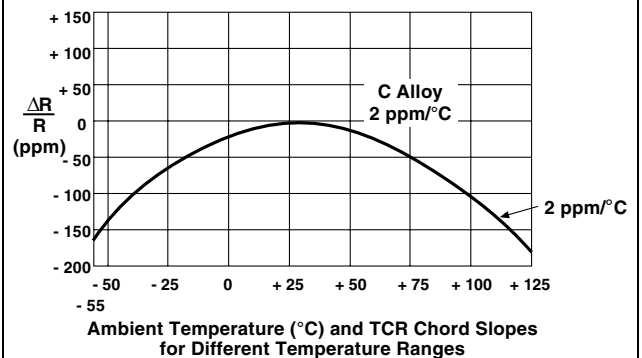
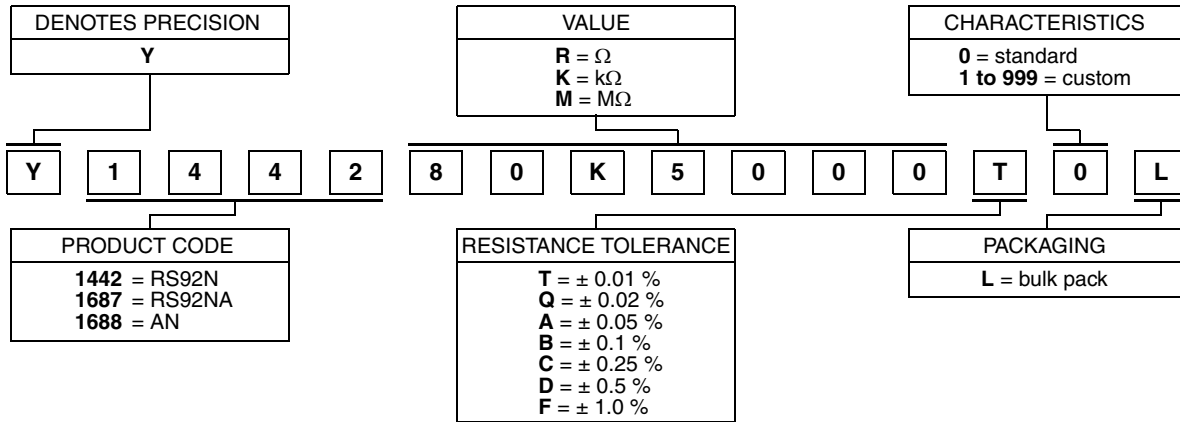



TABLE 5 - GLOBAL PART NUMBER INFORMATION (1)

NEW GLOBAL PART NUMBER: Y144280K5000T0L (preferred part number format)



FOR EXAMPLE: ABOVE GLOBAL ORDER Y1442 80K5000 T 0 L:

TYPE: RS92N
 VALUE: 80.5 $k\Omega$
 ABSOLUTE TOLERANCE: $\pm 0.01\%$
 TERMINATION: standard
 PACKAGING: bulk pack

HISTORICAL PART NUMBER: RS92N 250R00 T B (will continue to be used)

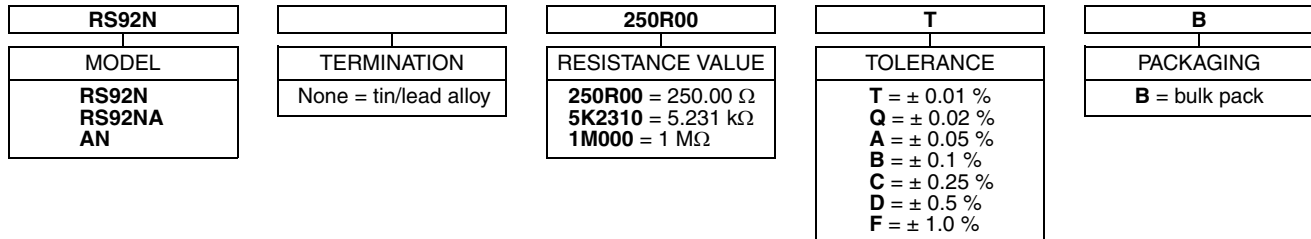

Note

(1) For non-standard requests, please contact application engineering.



Disclaimer

All product specifications and data are subject to change without notice.

Vishay Intertechnology, Inc., its affiliates, agents, and employees, and all persons acting on its or their behalf (collectively, "Vishay"), disclaim any and all liability for any errors, inaccuracies or incompleteness contained herein or in any other disclosure relating to any product.

Vishay disclaims any and all liability arising out of the use or application of any product described herein or of any information provided herein to the maximum extent permitted by law. The product specifications do not expand or otherwise modify Vishay's terms and conditions of purchase, including but not limited to the warranty expressed therein, which apply to these products.

No license, express or implied, by estoppel or otherwise, to any intellectual property rights is granted by this document or by any conduct of Vishay.

The products shown herein are not designed for use in medical, life-saving, or life-sustaining applications unless otherwise expressly indicated. Customers using or selling Vishay products not expressly indicated for use in such applications do so entirely at their own risk and agree to fully indemnify Vishay for any damages arising or resulting from such use or sale. Please contact authorized Vishay personnel to obtain written terms and conditions regarding products designed for such applications.

Product names and markings noted herein may be trademarks of their respective owners.