

## 4-CH Constant Current LED Driver for Display Backlight

### General Description

The RT6033A is a 4-CH constant current sink LED drivers with Dynamic Headroom Control (DHC) function. RT6033A can provide well current matching ability, adjustable VSET to choose the suitable dropout voltage across the MOS / BTJ. Beside that, DHC will provide the stable VFB dimming, thus voltage ripple is kept as small even during the dimming.

The RT6033A provides four channel constant currents with less than 3% differences in output current value among the 4-CH and ICs respectively. The constant current is adjustable by each channel external resistor (RSET). The LED brightness can also be adjusted via the EN/PWM pin with PWM dimming duty from 1% to 100%. The RT6033A can operate with external components for high current application

The DHC function generates feedback signal to DC/DC control loop and regulate the output voltage. When RT6033A selects the LED string with the highest forward voltage, and then the COMP is defined according to that particular string. The COMP voltage is then compared with the voltage of VSET to determine the voltage level of VFB, which therefore control the switching of the primary controller.

RT6033A's protection features include Short LED Protection (SLP), Open LED Protection (OLP) and Over Temperature Protection (OTP). When any channel triggers protection function, LED will be turned off and the FAULT pin will pull low.

The RT6033A is available in SOP-16 package to achieve optimized solution for PCB space.

### Simplified Application Circuit

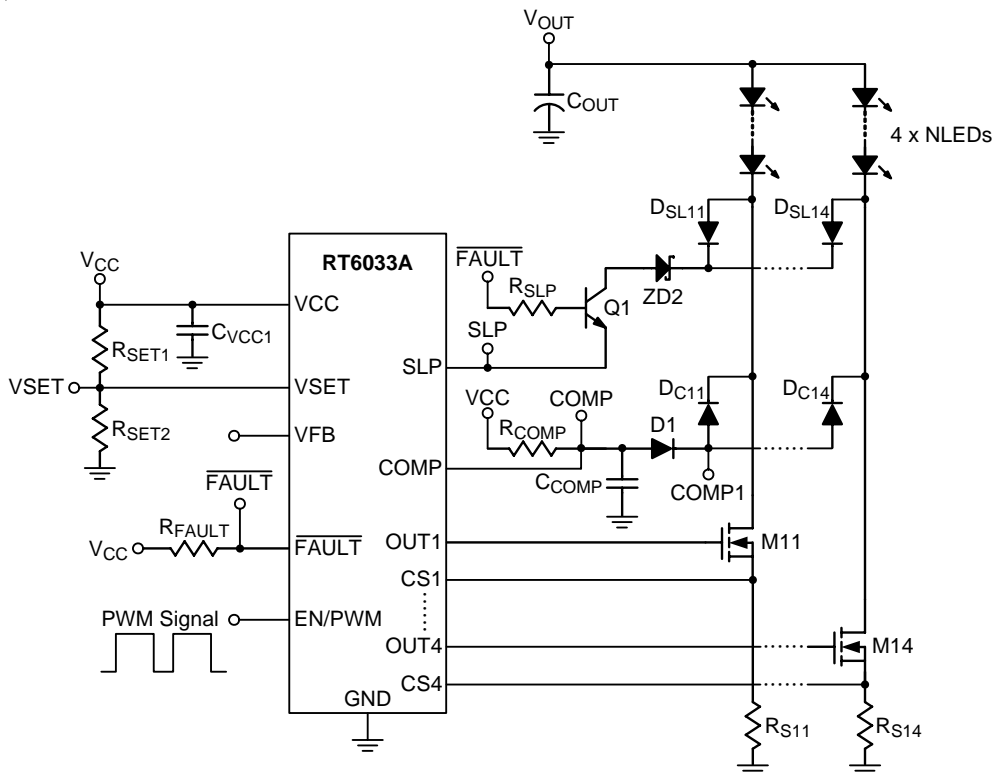

## Features

- Wide Input Supply Voltage Range : 5V to 24V
- Adjustable Channel Current
- 3% Current Sense Amplifier Input Offset
- VCC Under Voltage Lockout
- Thermal Shutdown
- Adjustable Dynamic Headroom Control (DHC) Function
- LED Open/Short Protection
- RoHS Compliant and Halogen Free

## Applications

- LCD TV, MNT Display Backlight
- DC/DC or AC/DC LED Driver Application
- General Purpose Constant Current Source
- Architectural and Decorative LED Lighting
- LED Street Lighting

## Marking Information

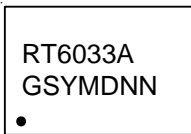

RT6033AGS : Product Number  
 YMDNN : Date Code

## Ordering Information

RT6033A □ □  
 □ Package Type  
   S : SOP-16  
 □ Lead Plating System  
   G : Green (Halogen Free and Pb Free)

Note :

Richtek products are :

- ▶ RoHS compliant and compatible with the current requirements of IPC/JEDEC J-STD-020.
- ▶ Suitable for use in SnPb or Pb-free soldering processes.

## Pin Configurations

(TOP VIEW)

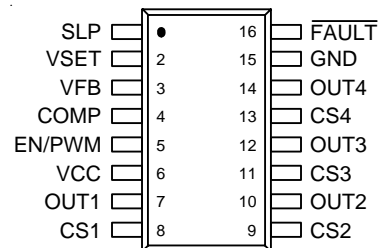

SOP-16

## Functional Pin Description

Pin No.	Pin Name	Pin Function
1	SLP	Short LED Protection Sense Input.
2	VSET	Highest Voltage LED String.
3	VFB	Feedback Signal Output.
4	COMP	LED String Voltage Sense.
5	EN/PWM	Chip Enable (Active High) and PWM Pulse Dimming Input.
6	VCC	Power Supply Input.
7	OUT1	Channel 1 Current Gate Driver Output.
8	CS1	Channel 1 Current Sense Input.
9	CS2	Channel 2 Current Sense Input.
10	OUT2	Channel 2 Current Gate Driver Output.
11	CS3	Channel 3 Current Sense Input.
12	OUT3	Channel 3 Current Gate Driver Output.
13	CS4	Channel 4 Current Sense Input.
14	OUT4	Channel 4 Current Gate Driver Output.
15	GND	Power Ground.
16	FAULT	Open Drain Output for Fault Detection.

**Function Block Diagram**

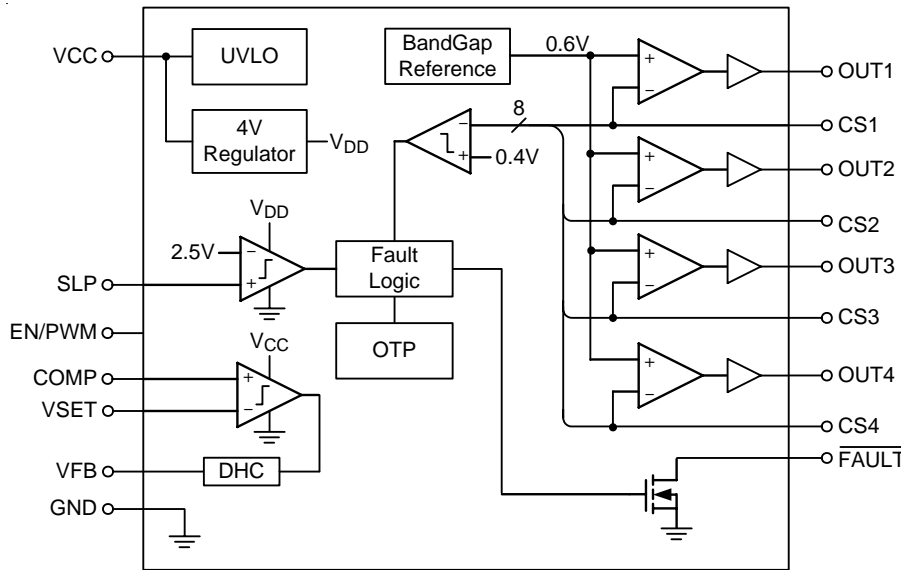

**Operation**

The RT6033A is a 4-CH LED driver integrated with a feedback controller. When EN/PWM is go high and VCC is exceeded the voltage of the UVLO, it will start-up. During the first 256μs, RT6033A will detect which channels are using. If the CS pin < 0.4V, that channel is defined as "USED" channel. Otherwise, the channel is defined as "UN-USED" if CS pin > 0.4V. And the diver of this channel will be turned off after the un-used checking.

Then RT6033A will enter the soft-start state, VFB is kept as 3.3V. After that period, RT6033A selects the LED string with the highest forward voltage, and then COMP is defined according to that particular string. The voltage of COMP will further compare with the voltage of VSET and determine the voltage level of VFB.

Beside that, the protection function is activated after the fault blanking period. If the LED string is broken or shorted, RT6033A will turn off channels. The internal MOS of the FAULT will be turned-on, users could add an external pull-high resistor to get this alarm signal.

Timing Diagram

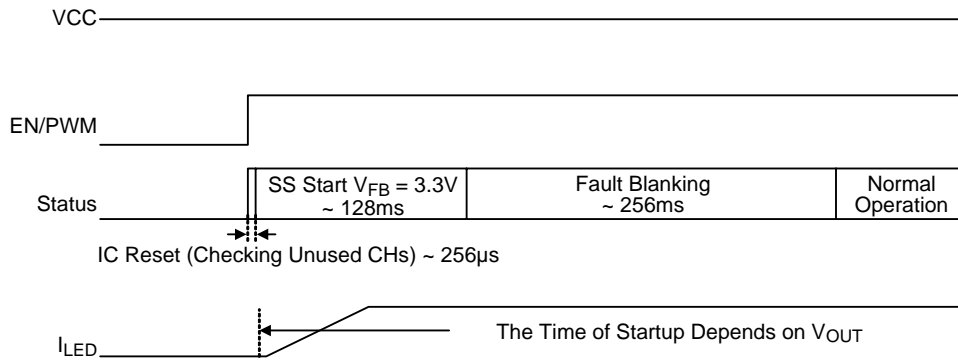

Figure 1. Power On by EN/PWM Pin Signals

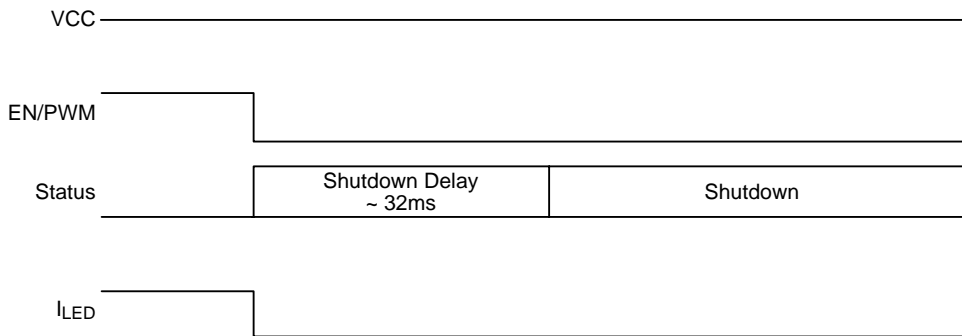

Figure 2. Power Off by EN/PWM Pin Signals

**Absolute Maximum Ratings** (Note 1)

- Supply Input Voltage, VCC ----- -0.3V to 30V
- CS1 to CS4 ----- -0.3V to 7V
- SLP, EN/PWM, COMP, VSET ----- -0.3V to 16V
- (OUT1 to OUT4), VFB, FAULT ----- -0.3V to 16V
- Power Dissipation, P<sub>D</sub> @ T<sub>A</sub> = 25°C
- SOP-16 ----- 1.176W
- Package Thermal Resistance (Note 2)
- SOP-16, θ<sub>JA</sub> ----- 85°C/W
- Lead Temperature (Soldering, 10 sec.) ----- 260°C
- Junction Temperature ----- 150°C
- Storage Temperature Range ----- -65°C to 150°C
- ESD Susceptibility (Note 3)
- HBM (Human Body Model) ----- 2kV
- MM (Machine Model) ----- 200V

**Recommended Operating Conditions** (Note 4)

- Supply Input Voltage, VCC ----- 5V to 24V
- Junction Temperature Range ----- -40°C to 125°C
- Ambient Temperature Range ----- -40°C to 85°C

**Electrical Characteristics**

(V<sub>CC</sub> = 12V, T<sub>A</sub> = 25°C, unless otherwise specified)

Parameter	Symbol	Test Conditions	Min	Typ	Max	Unit
Supply Current	I <sub>VCCON</sub>	V <sub>EN/PWM</sub> = 4V	--	6	--	mA
Shutdown Current	I <sub>SHDN</sub>	V <sub>EN/PWM</sub> = 0V	--	20	--	μA
Under Voltage Lockout Threshold	V <sub>UVLO</sub>		--	3.7	--	V
Under Voltage Lockout Threshold Hysteresis	ΔV <sub>UVLO</sub>		--	500	--	mV
<b>Enable / PWM</b>						
EN/PWM Input Threshold Voltage	Logic-High	V <sub>IH</sub>	2	--	--	V
	Logic-Low	V <sub>IL</sub>	--	--	1	
Shutdown Delay	t <sub>SHDN</sub>		--	32	--	ms
EN/PWM Sink Current	I <sub>IH</sub>		--	--	2	μA
PWM Dimming Frequency	f <sub>PWM</sub>		90	--	500	Hz
PWM Dimming Duty		PWM Frequency = 500Hz	1	--	100	%
<b>Current Sink</b>						
CSx Reference Voltage	V <sub>REF</sub>	V <sub>EN/PWM</sub> = 4V (Note 5)	582	600	618	mV
Channel to Channel Accuracy	V <sub>MATCH</sub>	PWM Frequency = 500Hz, Duty = 80%	--	2.5	--	%

Parameter	Symbol	Test Conditions	Min	Typ	Max	Unit
<b>Output Pins Capability</b>						
OUTx Source Current	$I_{Gsr}$		5	10	22	mA
OUTx Sink Current	$I_{Gsk}$		--	5	--	mA
VSET Voltage Range	$V_{SET}$		2	--	10	V
VFB Output Voltage Range	$V_{FB(MAX)}$	$V_{VSET} = 3V, V_{COMP} = 2V$	--	3.3	--	V
	$V_{FB(MIN)}$	$V_{VSET} = 2V, V_{COMP} = 3V$	--	12	--	mV
VFB Source Current	$I_{FBsr}$	$V_{VSET} = 2V, V_{COMP} = 3V, V_{VFB} = 1.5V$	--	100	--	$\mu A$
VFB Sink Current	$I_{FBsk}$	$V_{VSET} = 3V, V_{COMP} = 2V, V_{FB} = 1.5V$	--	1.8	--	mA
<b>Protection</b>						
Short LED Protection	$V_{SLP}$		2.5	--	--	V
Current Sink of SLP	$I_{SLP}$		--	100	--	$\mu A$
Open LED Protection	$V_{OLP}$		--	0.4	--	V
Over Temperature Protection	$T_{OTP}$		--	140	--	$^{\circ}C$
OTP Hysteresis	$\Delta T_{OTP}$		--	30	--	$^{\circ}C$
<b>Timing</b>						
Reset	$t_{RESET}$		--	256	--	$\mu s$
Soft-Start	$t_{SS}$	(Note 6)	--	128	--	ms
Fault Blanking Time	$t_{FB}$	(Note 7)	--	256	--	ms

**Note 1.** Stresses beyond those listed "Absolute Maximum Ratings" may cause permanent damage to the device. These are stress ratings only, and functional operation of the device at these or any other conditions beyond those indicated in the operational sections of the specifications is not implied. Exposure to absolute maximum rating conditions may affect device reliability.

**Note 2.**  $\theta_{JA}$  is measured at  $T_A = 25^{\circ}C$  on a high effective thermal conductivity four-layer test board per JEDEC 51-7.

**Note 3.** Devices are ESD sensitive. Handling precaution is recommended.

**Note 4.** The device is not guaranteed to function outside its operating conditions.

**Note 5.**  $CS_X$  should be left floating for unused channel(s).

**Note 6.** During  $t_{SS}$ ,  $V_{FB} = 3.3V$  and the protection function SLP and OLP are disabled.

**Note 7.** The protection function SLP and OLP are disabled. Before the end of  $t_{FB}$ .

**Typical Application Circuit**

For General Application

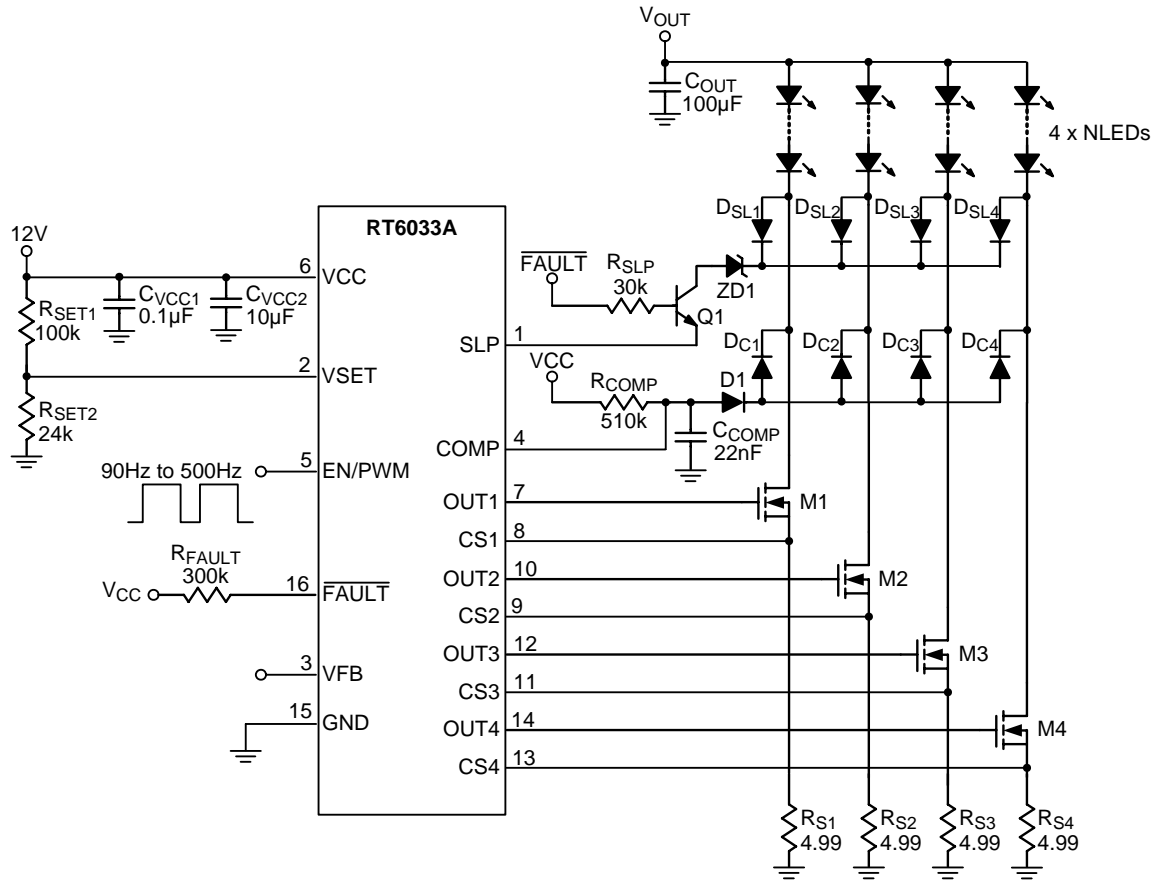





For Application Using Multi-Chip Boost Converter System

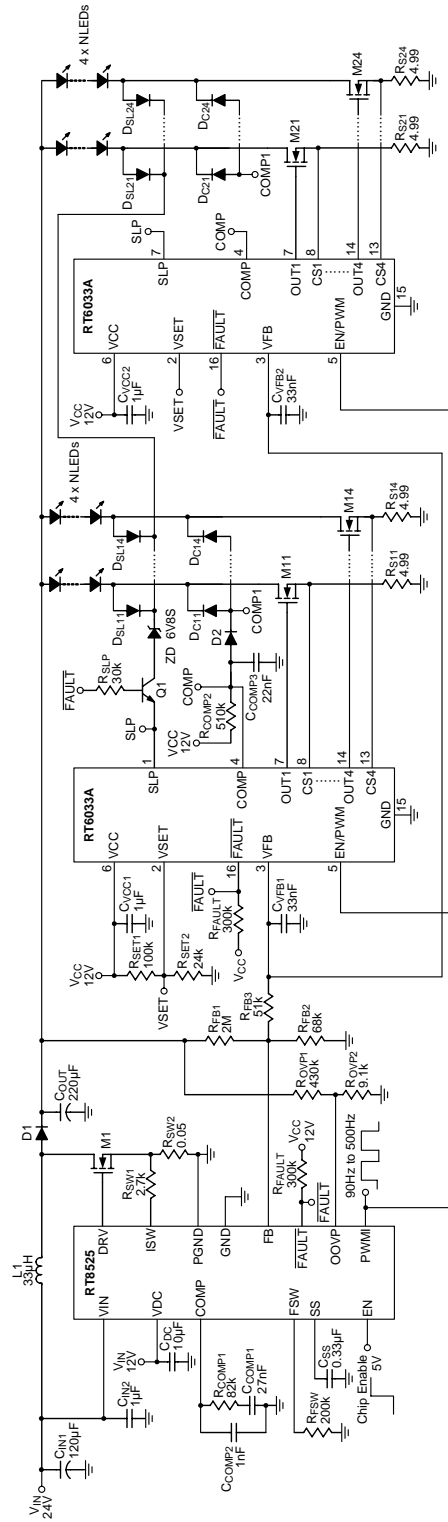

Typical Operating Characteristics

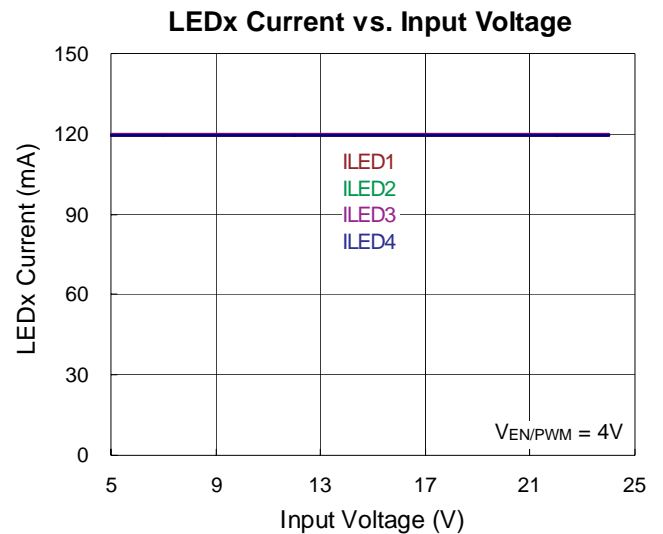
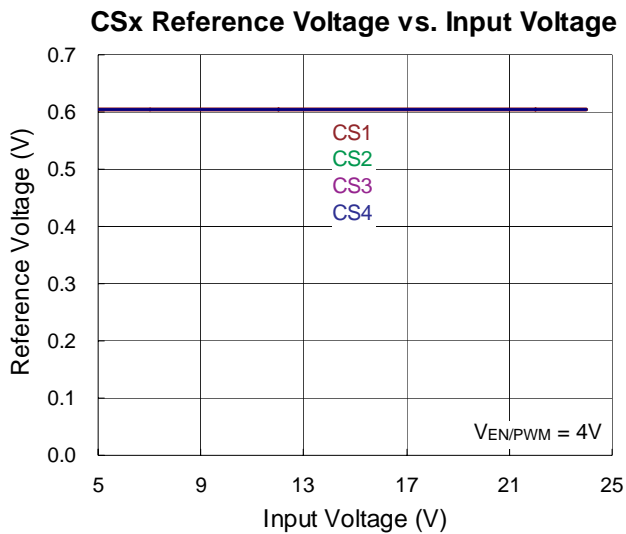
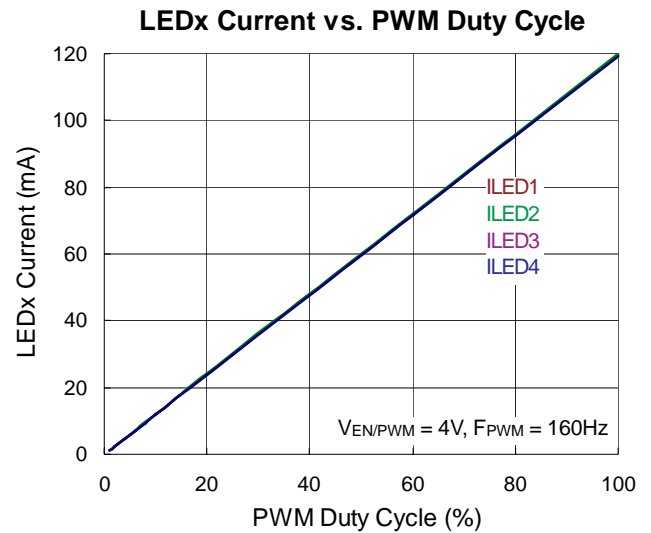
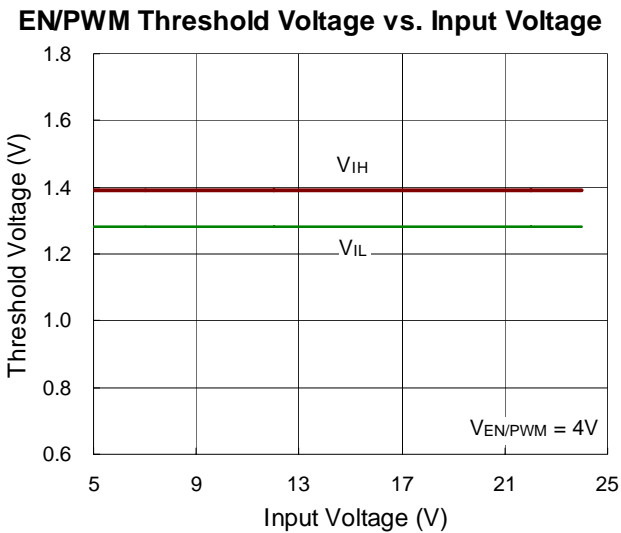
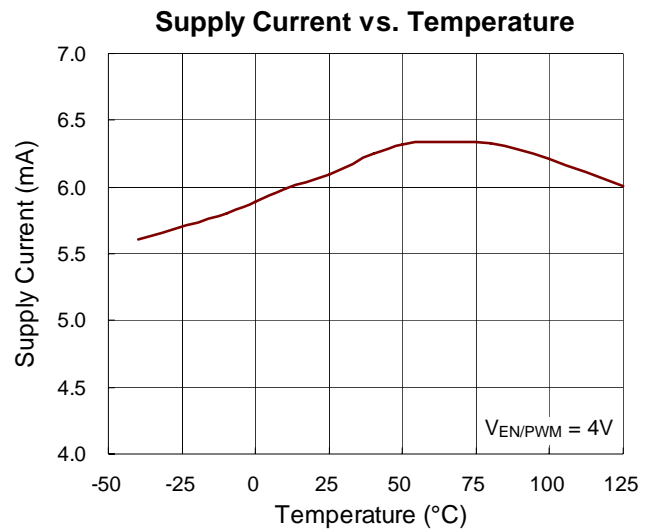
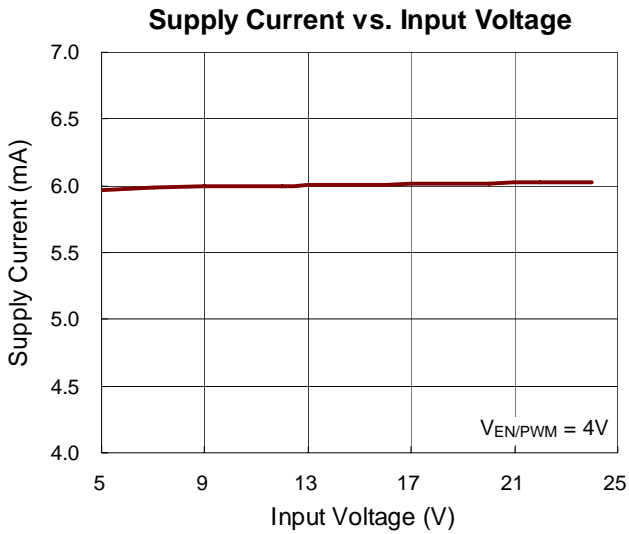

**VFB Output Voltage vs. Input Voltage**

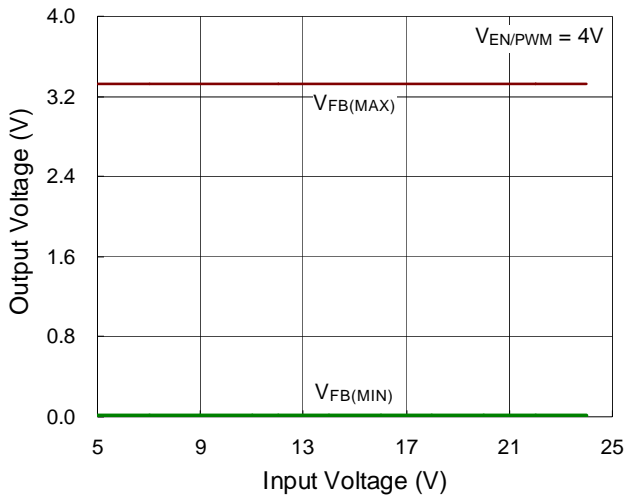

**Power On**

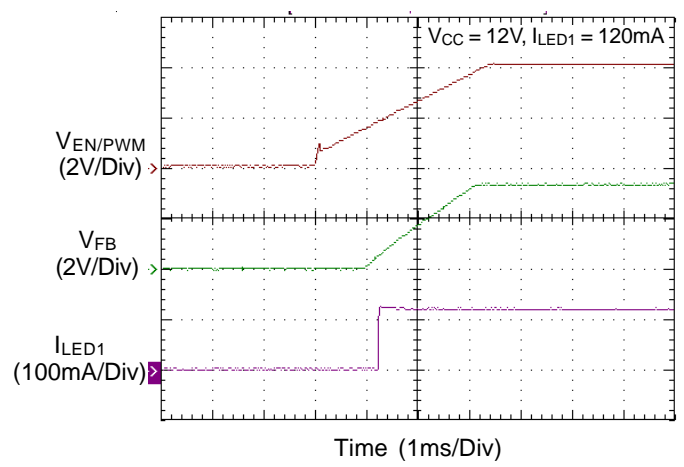

**Power Off**

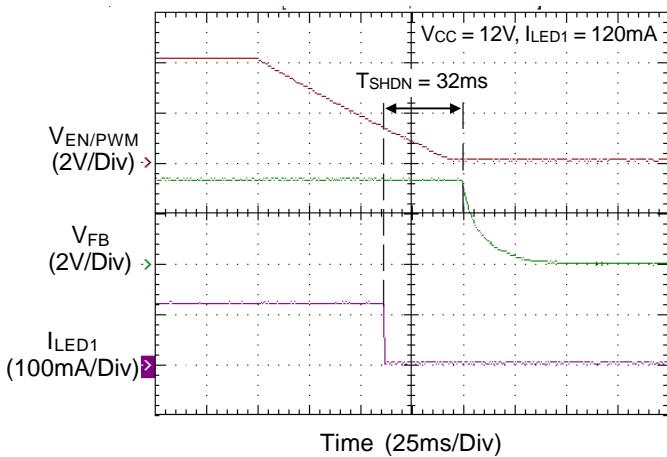

**DHC Function**

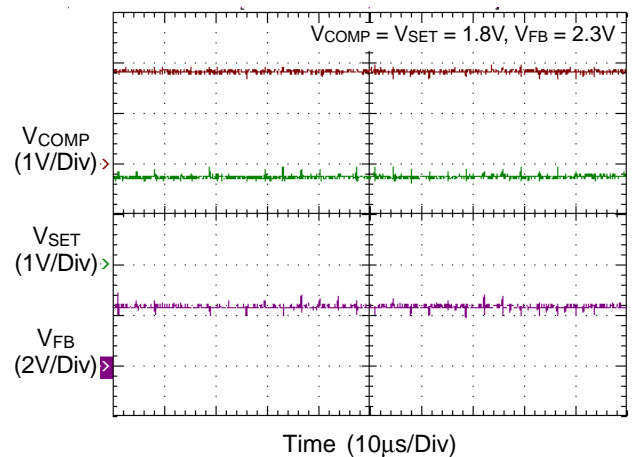

**Open Protection**

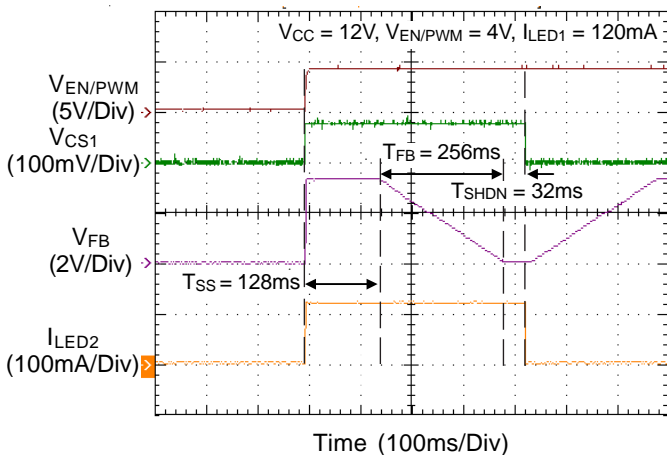

**Short Protection**

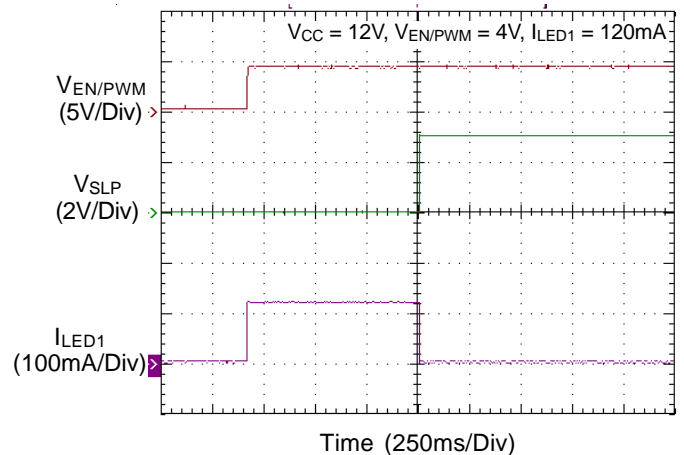

## Applications Information

The RT6033A is an 4-CH LED current source controller. This device can also drive an external N-MOSFET for various applications. The RT6033A regulates the lowest cathode voltage of the LED strings and generates a feedback control signal to a primary controller to regulate the LED current. Each LED channel current is accurately matched and controlled by sensing an external resistor in series with the MOSFET. All channels' LED brightness can be precisely controlled by applying a PWM signal to the EN/PWM pin. The RT6033A also features several protection functions including LED short protection, LED open protection, and over temperature protection. The device is totally turned off by pulling the EN/PWM pin low after 32ms.

### Under Voltage Lockout

To prevent abnormal device operation caused by low input voltages, an under voltage lockout is included which shutdown the device at voltages lower than 3.7V. All functions will be turned off in this state.

### LED Current Setting

The loop structure keeps the CS pin voltage,  $V_{CSx}$  ( $x = 1$  to 4), equal to the reference voltage,  $V_{REF}$ . Therefore, by connecting the resistor,  $R_{Sx}$  ( $x = 1$  to 4) between the CS pin and GND, the LED current can be determined via the value of  $R_{Sx}$ . The maximum LED current is calculated according to the following equation :

$$I_{LEDx} = \frac{V_{CSx}}{R_{Sx}}$$

### Brightness Control

The RT6033A provides a PWM dimming function. The LED string current sinks are turned on/off by the PWM signals applied at the EN/PWM pin. Thus, the average LED current can be calculated according to the following equation :

$$\text{Average } I_{LEDx} = \frac{V_{CS}}{R_{Sx}} \times \text{duty}$$

where duty is the duty cycle of the PWM signal.

### Dynamic Headroom Control Function

The Dynamic Headroom Control (DHC) function is used to generate feedback signal to adjust primary converter output voltage with regulate the LED current of the

RT6033A. The feedback level of the whole system is defined by the resistive voltage divider ( $R_{SET1}$ ,  $R_{SET2}$ ) at the VSET pin. The minimum setting of the VSET pin voltage is according to the following equation :

$$\text{Minimum } V_{VSET} = V_F + V_{DS} + 0.6$$

$$\text{Where } V_F = V_{D1} + V_{DC1}$$

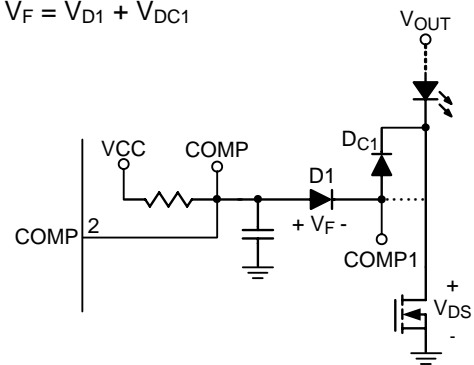

Figure 3. COMP Circuit

where  $V_F$  ( $V_{D1} + V_{DC1}$ ) is the forward voltage of the diodes and  $V_{DS}$  is the dropout voltage of the external MOSFET. Besides, it can improve thermal performance of external MOSFET by VSET pin voltage setting.

The R1, R2 and R3 selection is shown in below equation :

$$V_{OUT(\text{default})} = \left(\frac{R_2}{R_1} + 1\right) \times V_{REF}$$

$$V_{OUT^+(\text{MAX.})} = \left(\frac{R_2}{R_3}\right) \times (V_{REF} - 12\text{m}) + V_{OUT(\text{default})}$$

$$V_{OUT^-(\text{MIN.})} = \left(\frac{R_2}{R_3}\right) \times (V_{REF} - 3.3) + V_{OUT(\text{default})}$$

$$R3(\text{MIN.}) = \left| \frac{V_{FB} - V_{REF}}{I_{FB,SR(\text{MAX})}} \right|$$

Where  $V_{OUT}$  is converter output voltage,  $V_{REF}$  is converter reference voltage and typical  $I_{FB}$  is 100 $\mu$ A. The connection is shown as the following Figure 4.

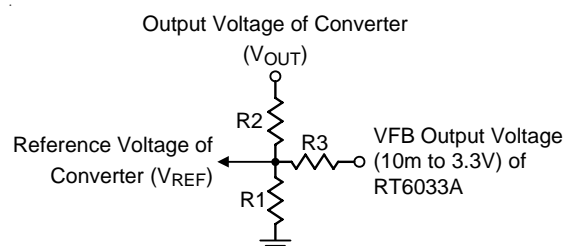

Figure 4. DHC Function Setting Circuit

**Chip Enable and PWM Dimming Operation**

Pull the EN/PWM pin low to drive the device into shutdown mode. Drive the EN pin high to turn on the device again. To control LED brightness, the RT6033A can perform dimming function by applying a PWM signal to the EN/PWM pin. The average LED current is proportional to the PWM signal duty cycle.

**MOSFET Selection**

The RT6033A is designed to drive on external N-MOSFET pass element. MOSFET selection criteria include threshold voltage,  $V_{GS(TH)}$ , maximum continuous drain current,  $I_D$ , on resistance,  $R_{DS(ON)}$ , maximum drain-to-source voltage,  $V_{DS(MAX)}$ , and package thermal resistance,  $\theta_{JA}$ .

**Input Capacitors Selection**

The input capacitor reduces current spikes from the input supply and minimizes noise injection to the converter. A ceramic capacitor is recommended for the input capacitor due to its high ripple current, high voltage rating and low ESR, which makes them ideal for switching regulator applications. A 10 $\mu$ F capacitance is sufficient for most applications. Nevertheless, a higher or lower value may be used depending on the noise level from the input supply and the input current to the converter. Note that the voltage

rating of the input capacitor must be greater than the maximum input voltage. For better voltage filtering, ceramic capacitors with low ESR are recommended. X5R and X7R types are suitable because of their wide voltage and temperature ranges.

**Diode Selection**

The reverse voltage rating is important parameters for consideration when making a diode selection. Make sure that the diode's reverse voltage rating exceeds the maximum output voltage.

**Power On/Off Sequence**

When converter's output and VCC is already ready. EN/PWM pulled high will enable the RT6033A, and IC will check channel unused or not in first period (256 $\mu$ s). The unused channel must be floating. The second period is 128ms soft start time, the RT6033A feedback voltage is 3.3V in this period. Then, IC gets into the fault blanking time (256ms) when PWM duty is 100% since fault blanking counter depends on the PWM on period. After the third period, fault function will turn on. About power off sequence, IC will shut down after 32ms when EN/PWM pin is pulled low. The power on/off flow-chart are shown as the following Figure 5.

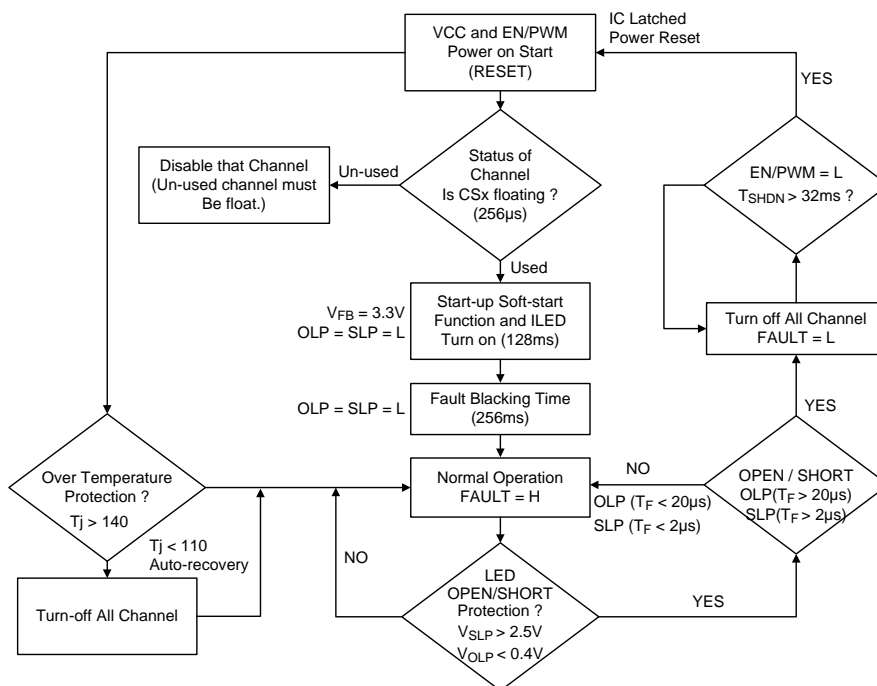

Figure 5. Power On/Off Flow Chart

### Open Protection

If the CS pin < 0.4V after a fault blanking period, the counter will be triggered when PWM is high. Moreover, there is a 4μs blanking time on every rising part of PWM. When the counter accumulates to 20μs, all channels will be off and latched. The FAULT will be pulled low. The fault state can only be released by pulling the EN/PWM pin low for 32ms.

### Short Protection

If the SLP pin > 2.5V after a fault blanking period, the counter will be triggered when PWM is high. Moreover, there is a 4μs blanking time on every rising part of PWM. When the counter accumulates to 2μs, all channels will be off and latched. The FAULT will be pulled low. The fault state can only be released by pulling the EN/PWM pin for 32ms.

### Over Temperature

The RT6033A has an Over Temperature Protection (OTP) function to prevent excessive power dissipation from overheating the device. The OTP shuts down switching operation and disables all channels if the junction temperature exceeds 140°C and sends a fault signal. The channels are re-enabled when the junction temperature cools down by approximately 30°C.

### Thermal Considerations

For continuous operation, do not exceed absolute maximum junction temperature. The maximum power dissipation depends on the thermal resistance of the IC package, PCB layout, rate of surrounding airflow, and difference between junction and ambient temperature. The maximum power dissipation can be calculated by the following formula :

$$P_{D(MAX)} = (T_{J(MAX)} - T_A) / \theta_{JA}$$

where  $T_{J(MAX)}$  is the maximum junction temperature,  $T_A$  is the ambient temperature, and  $\theta_{JA}$  is the junction to ambient thermal resistance.

For recommended operating condition specifications, the maximum junction temperature is 125°C. The junction to ambient thermal resistance,  $\theta_{JA}$ , is layout dependent. For SOP-16 package, the thermal resistance,  $\theta_{JA}$ , is 85°C/W on a standard JEDEC 51-7 four-layer thermal test board.

The maximum power dissipation at  $T_A = 25^\circ\text{C}$  can be calculated by the following formula :

$$P_{D(MAX)} = (125^\circ\text{C} - 25^\circ\text{C}) / (85^\circ\text{C/W}) = 1.176\text{W for SOP-16 package}$$

The maximum power dissipation depends on the operating ambient temperature for fixed  $T_{J(MAX)}$  and thermal resistance,  $\theta_{JA}$ . The derating curve in Figure 6 allows the designer to see the effect of rising ambient temperature on the maximum power dissipation.

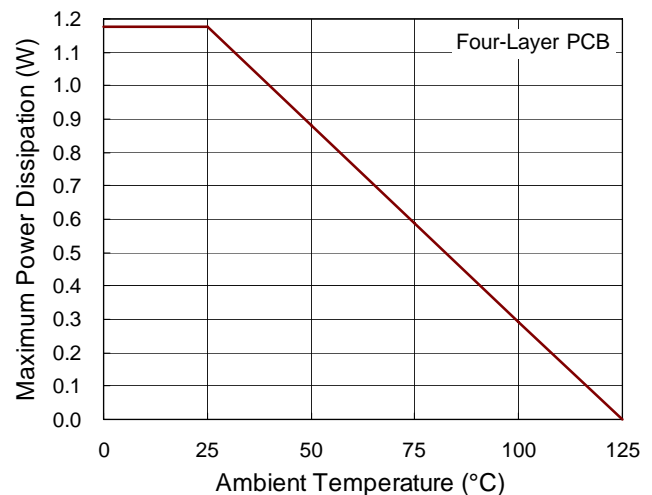

Figure 6. Derating Curve of Maximum Power Dissipation

### Layout Consideration

Follow the PCB layout guidelines for optimal performance of the RT6033A.

- ▶ Keep the traces of the main current paths as short and wide as possible.
- ▶ Put the input capacitor as close as possible to the device pins ( $V_{CC}$  and GND).
- ▶ The VFB path must be kept away from noise and short enough to connect  $V_{REF}$ .
- ▶ The drain pad must large enough to reduce thermal on MOSFET.
- ▶ In order maintain  $I_{LEDx}$  current match, the grounding paths of each  $R_{Sx}$  should as similar as possible.

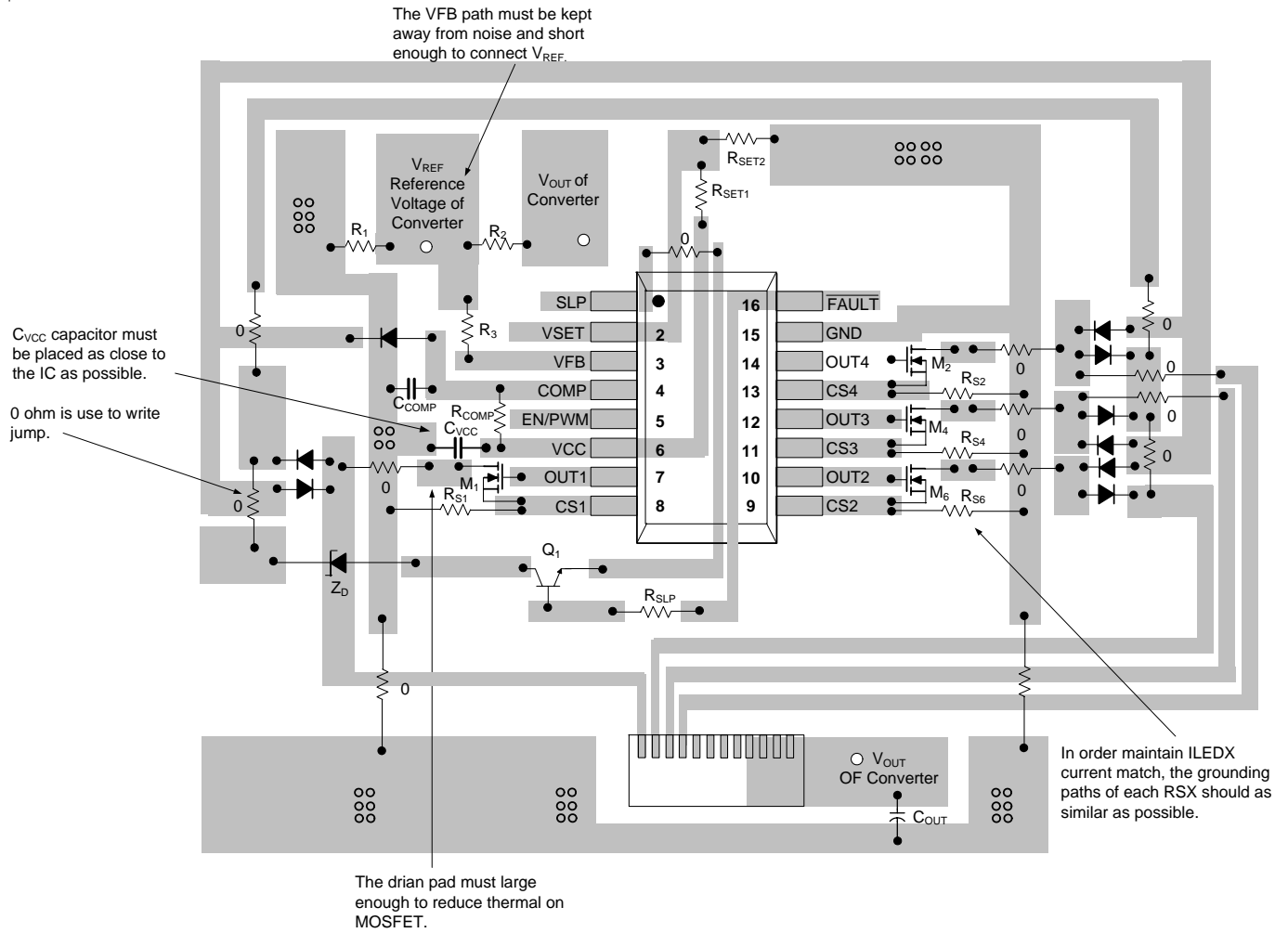
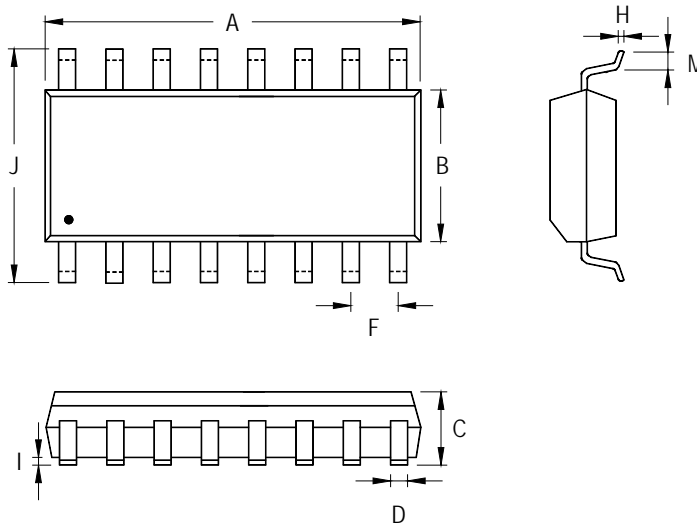

Figure 7. PCB Layout Guide for Single-clad Board

Outline Dimension



Symbol	Dimensions In Millimeters		Dimensions In Inches	
	Min	Max	Min	Max
A	9.804	10.008	0.386	0.394
B	3.810	3.988	0.150	0.157
C	1.346	1.753	0.053	0.069
D	0.330	0.508	0.013	0.020
F	1.194	1.346	0.047	0.053
H	0.178	0.254	0.007	0.010
I	0.102	0.254	0.004	0.010
J	5.791	6.198	0.228	0.244
M	0.406	1.270	0.016	0.050

16-Lead SOP Plastic Package

Richtek Technology Corporation

5F, No. 20, Taiyuen Street, Chupei City  
 Hsinchu, Taiwan, R.O.C.  
 Tel: (8863)5526789

Richtek products are sold by description only. Richtek reserves the right to change the circuitry and/or specifications without notice at any time. Customers should obtain the latest relevant information and data sheets before placing orders and should verify that such information is current and complete. Richtek cannot assume responsibility for use of any circuitry other than circuitry entirely embodied in a Richtek product. Information furnished by Richtek is believed to be accurate and reliable. However, no responsibility is assumed by Richtek or its subsidiaries for its use; nor for any infringements of patents or other rights of third parties which may result from its use. No license is granted by implication or otherwise under any patent or patent rights of Richtek or its subsidiaries.