

SmartJitter™ Multi-Mode Flyback Controller

General Description

The RT7738M is enhanced high efficient multi-mode PWM flyback controller with proprietary SmartJitter™ technology. The innovative SmartJitter™ technology can not only reduces the EMI emissions of SMPS when the system enters green mode, but also eliminates the output jittering ripple. Also, the RT7738M feature Continuous Conduction Mode (CCM) and valley switching multi-mode control to optimize the product performance. To meet the stringent trend toward performance in recent years, the RT7738M is the best choice for product designers.

The RT7738M is available in SOT-23-6 package, and it is a current mode PWM controller. Comprehensive protection and programmable functions are built-in, including a programmable propagation delay time compensation, a programmable output Over-Voltage Protection (OVP), a programmable external Over-Temperature Protection (OTP), and a programmable bulk capacitor Brown-in/Brown-out protection. With the above features, the RT7738M is a cost-effective and compact solution for AC/DC products.

Features

- Proprietary SmartJitter™ Technology
 - ▶ Reducing EMI Emissions of SMPS
 - ▶ Output Jittering Ripple Elimination
- Continuous Conduction Mode (CCM) and Valley Switching Mode Control
- Ultra-low Start-up current (<3μA)
- Accurate Over-Load Protection (OLP)
- Programmable Propagation Delay Time Compensation
- Programmable Output Over-Voltage Protection
- Programmable External Over-Temperature Protection
- Programmable Bulk Capacitor Brown-in/Brown-out Protection
- Driver Capability : 200mA/–300mA
- High Noise Immunity

Applications

- Switching AC/DC Adaptor
- NB Adaptor
- TV/Monitor Standby Power
- PC Peripherals

Simplified Application Circuit

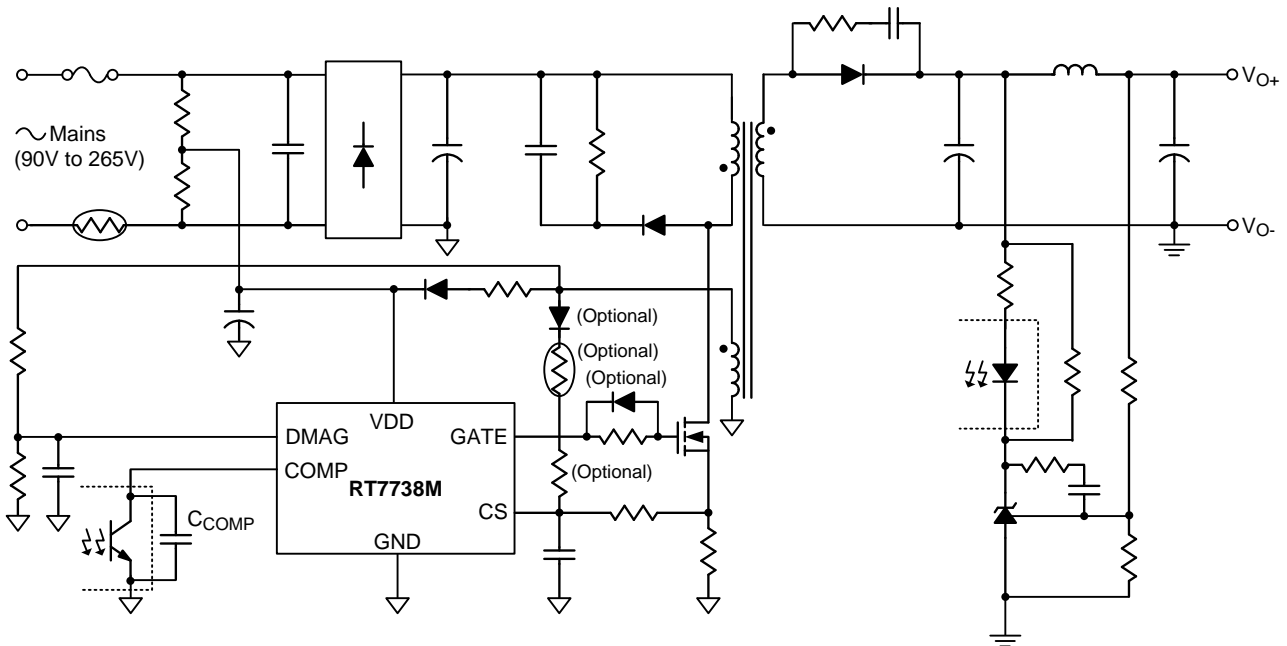

Ordering Information

RT7738M□□
 □ Package Type
 E : SOT-23-6
 □ Lead Plating System
 G : Green (Halogen Free and Pb Free)

Marking Information

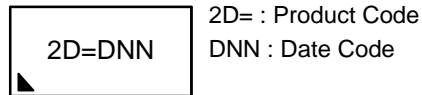

Pin Configurations

(TOP VIEW)

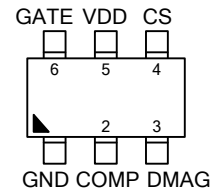

SOT-23-6

Note :

Richtek products are :

- ▶ RoHS compliant and compatible with the current requirements of IPC/JEDEC J-STD-020.
- ▶ Suitable for use in SnPb or Pb-free soldering processes.

Functional Pin Description

Pin No.	Pin Name	Pin Function
1	GND	Ground of the Controller.
2	COMP	Feedback Voltage Input. Connect an opto-coupler to close the control loop and achieve output voltage regulation.
3	DMAG	Demagnetization Pin. Input and output voltage detection from auxiliary winding.
4	CS	Current Sense Input. The current sense resistor between this pin and GND is used for current limit setting.
5	VDD	Supply Voltage Input. The controller will be enabled when VDD exceeds V_{TH_ON} and disabled when VDD decreases lower than V_{TH_OFF} .
6	GATE	Gate Driver Output Pin.

Function Block Diagram

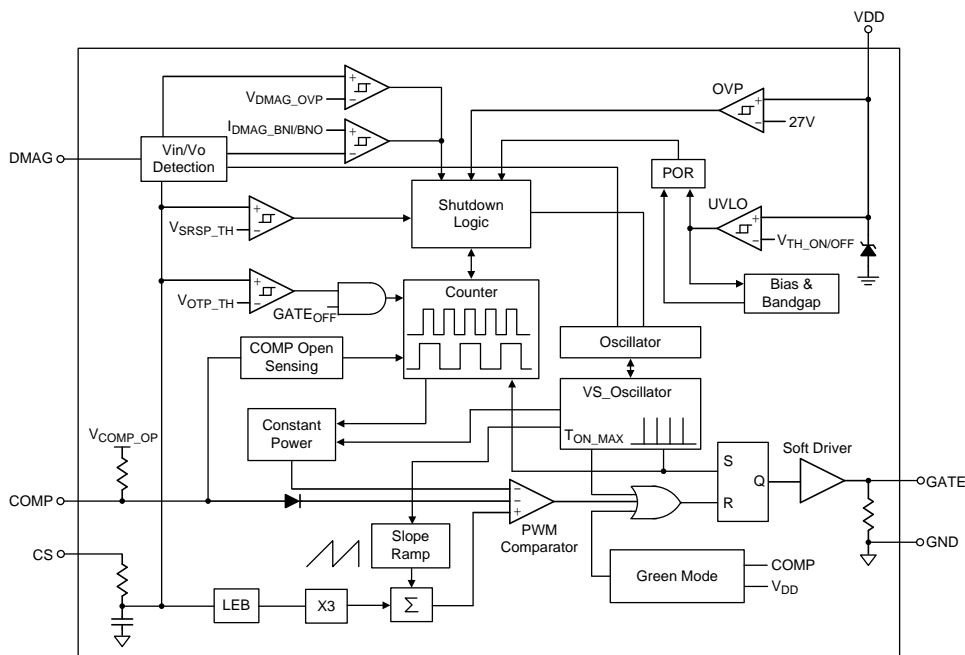

Operation

Multi-mode PWM

The RT7738M is a multi-mode PWM controller, and a constant oscillator is built-in to allow the system operating in CCM. As the load decreases, the system enters DCM, and the oscillator converts to valley switching mode control. In lighter load or no load conditions, the controller enters green mode. The RT7738M provides multi-mode control to optimize the product performance under different load conditions.

Oscillator

The oscillator runs at 65kHz and features frequency jittering function. The saw-tooth slope compensation, maximum duty cycle pulse and over-load protection slope are built-in. Its jitter depth is proportion of oscillator frequency where Δf is frequency jittering range, and T_{JIT} is frequency jittering period.

Leading Edge Blanking (LEB)

To prevent unexpectedly gate switching interruption from the initial spike on CS pin, the LEB delay is designed to block this spike at the beginning of gate switching.

Gate Driver

A totem pole gate driver is designed to meet both EMI and efficiency requirements in low power applications. An internal pull-low circuit is activated after pretty low V_{DD} to prevent external MOSFET from accidentally turning on during UVLO.

DMAG Pin

The DMAG pin detects the input voltages of bulk capacitor and output voltage by auxiliary winding and resistor divider. According to the DMAG signal, the RT7738M provides protections, including output over-voltage protection, and programmable bulk capacitor Brown-in/Brown-out protection.

Over-Load Protection

In over-load conditions, current limit for a long time will lead to system thermal stress problem. To further protect the system, the RT7738M is designed with a proprietary prolonged turn-off period during hiccup. The power loss and temperature during OLP are averaged to an acceptable level over the ON/OFF cycle.

CS Pin Open Protection

When the CS pin is opened, the controller will shut down after a few cycles.

Internal VDD Over-Voltage Protection

Output voltage can be roughly sensed by the VDD pin. If the sensed voltage reaches V_{OVP} threshold, the controller shuts down after deglitch delay.

Feedback Open and Opto-Coupler Short

If the output voltage feedback loop is open or the opto-coupler is shorted, the OVP/OLP function will be triggered depending on which one occurs first.

Output Short Protection

The RT7738M implements output short protection by detecting output signal of DMAG pin. It can minimize the power loss and temperature during output short, especially at high line input voltage.

Secondary Rectifier Short Protection

The current spike during secondary rectifier short test is extremely high because of the saturated main transformer. Meanwhile, the transformer acts like a leakage inductance. During high line, the current in power MOSFET is sometimes too high in OLP delay time. To offer better and easier protection design, the RT7738M shuts down after a few of cycles before fuse is impacted.

Absolute Maximum Ratings (Note 1)

- Supply Input Voltage, VDD to GND----- -0.3V to 30V
- GATE to GND----- -0.3V to 16.5V
- DMAG, COMP, CS to GND----- -0.3V to 6.5V
- Power Dissipation, P_D @ T_A = 25°C
SOT-23-6----- 0.38W
- Package Thermal Resistance (Note 2)
SOT-23-6, θ_{JA}----- 260.7°C/W
- Junction Temperature----- 150°C
- Lead Temperature (Soldering, 10 sec.)----- 260°C
- Storage Temperature Range----- -65°C to 150°C
- ESD Susceptibility (Note 3)
HBM (Human Body Model)----- 2.5kV
MM (Machine Model)----- 250V

Recommended Operating Conditions (Note 4)

- Supply Input Voltage, VDD----- 12V to 25V
- Junction Temperature Range----- -40°C to 125°C
- Ambient Temperature Range----- -40°C to 85°C

Electrical Characteristics

(V_{DD} = 15V, T_A = 25°C, unless otherwise specified)

Parameter	Symbol	Test Conditions	Min	Typ	Max	Unit
VDD Section						
VDD Over-Voltage Protection Level	V _{OVP}		26	27	28	V
On Threshold Voltage	V _{TH_ON}		13.5	14.5	15.5	V
Off Threshold Voltage	V _{TH_OFF}		8.5	9	9.5	V
VDD Holdup Mode Entry Point	V _{DD_ET}	V _{COMP} < 0.85V	9.5	10	10.5	V
VDD Holdup Mode Ending Point	V _{DD_ED}	V _{COMP} < 0.85V	10	10.5	11	V
Latch-off Clamping Voltage	V _{DD_LH}		--	5.5	--	V
Threshold Voltage for Latch-off Release	V _{LH_OFF}		--	5	--	V
Start-up Current	I _{DD_ST}	V _{DD} < V _{TH_ON} - 0.1V, T _A = -40°C to 85°C	--	0.5	3	μA
Latch-off Operating Current	I _{DD_LH}	T _A = -40°C to 85°C	2	--	10	μA
Operating Supply Current	I _{DD_OP1}	GATE pin open, V _{COMP} = 1.8V	--	1.8	--	mA
	I _{DD_OP2}	GATE pin open, V _{COMP} = 1.4V	--	1.4	--	

Parameter	Symbol	Test Conditions	Min	Typ	Max	Unit
I _{DD} Sinking Current	I _{DD_ARP}	During entering auto recovery protection, T _A = -40°C to 85°C	400	550	700	μA
Oscillator Section						
Normal PWM Frequency	f _{OSC}	V _{COMP} > V _{G_M_ET}	60	65	70	kHz
Maximum ON Time	T _{ON_MAX}	V _{COMP} = V _{COMP_OP} , f _{OSC} = 65kHz	10	11.8	13.8	μs
Minimum Green Mode Frequency	f _{GM_MIN}	V _{COMP} < V _{G_M_ED}	--	22.5	--	kHz
PWM Frequency Jittering Range	Δf		--	±6	--	%
PWM Frequency Jittering Period	T _{JIT}	f _{OSC} = 65kHz	--	16	--	ms
Frequency Variation Versus VDD Deviation	f _{DV}	V _{DD} = 9V to 23V	--	--	2	%
Frequency Variation Versus Temperature Deviation	f _{DT}	T _A = -30°C to 105°C	--	--	5	%
COMP Input Section						
Open Loop Voltage	V _{COMP_OP}	COMP pin open	--	2.5	--	V
Short Circuit Current of COMP	I _{ZERO}	V _{COMP} = 0V	--	0.135	--	mA
Delay Time of COMP Open-loop Protection	T _{OLP}	f _{OSC} = 65kHz	--	64	--	ms
Green Mode Entry Voltage	V _{G_M_ET}		--	1.75	--	V
Green Mode Ending Voltage	V _{G_M_ED}		--	1.6	--	V
Current Sense Section						
Maximum Current Limit	V _{CS_MAX}		0.38	0.40	0.42	V
Leading Edge Blanking Time	T _{LEB}		350	475	600	ns
Threshold Voltage of Secondary Rectifier Short Protection	V _{SRSP_TH}	(Note 5)	--	0.9	--	V
Threshold Voltage for External Over-temperature Protection Application	V _{OTP_TH}		--	0.2	--	V
Delay Time for External Over-temperature Protection	T _{D_OTP}	f _{OSC} = 65kHz	--	64	--	ms
GATE Section						
Rising Time	T _R	C _L = 1nF	--	250	--	ns
Falling Time	T _F	C _L = 1nF	--	30	--	ns
Gate Output Clamping Voltage	V _{CLAMP}	V _{DD} = 23V	--	13	--	V
DMAG Section						
Threshold Voltage of Over-voltage Protection	V _{DMAG_OVP}		2.45	2.5	2.55	V

Parameter	Symbol	Test Conditions	Min	Typ	Max	Unit
Blanking Time Before Over-voltage Protection of DMAG Pin	T _{BK_OVP}	V _{CS} = 0.36V	2.1	2.9	3.7	μs
Threshold Voltage of Under-voltage Protection	V _{DMAG_UVP}	After T _{D_OSP} , COMP pin open	0.3	0.4	0.5	V
Delay Time of Under-voltage Protection	T _{D_OSP}	f _{OSC} = 65kHz	--	16	--	ms
On Threshold Current	I _{DMAG_BNI}		141	160	179	μA
Threshold Current of Under-current Protection	I _{DMAG_BNO}		128	145	162	μA
Maximum Sourcing Current of DMAG Pin	I _{DMAG_MAX}	(Note 5)	--	--	1	mA
Delay Time of Under-current Protection	T _{D_BNO}	f _{OSC} = 65kHz	--	64	--	ms
Over-Temperature Protection (OTP) Section						
OTP Before Turn On	T _{OTP_INTH}	Built-in OTP (Note 5)	--	130	--	°C
OTP After Turn On	T _{OTP_STTH}	Built-in OTP (Note 5)	--	140	--	°C

Note 1. Stresses beyond those listed "Absolute Maximum Ratings" may cause permanent damage to the device. These are stress ratings only, and functional operation of the device at these or any other conditions beyond those indicated in the operational sections of the specifications is not implied. Exposure to absolute maximum rating conditions may affect device reliability.

Note 2. θ_{JA} is measured in natural convection (still air) at T_A = 25°C with the component mounted on a low effective thermal conductivity test board of JEDEC 51-3 thermal measurement standard.

Note 3. Devices are ESD sensitive. Handling precaution is recommended.

Note 4. The device is not guaranteed to function outside its operating conditions.

Note 5. Guaranteed by design.

Typical Application Circuit

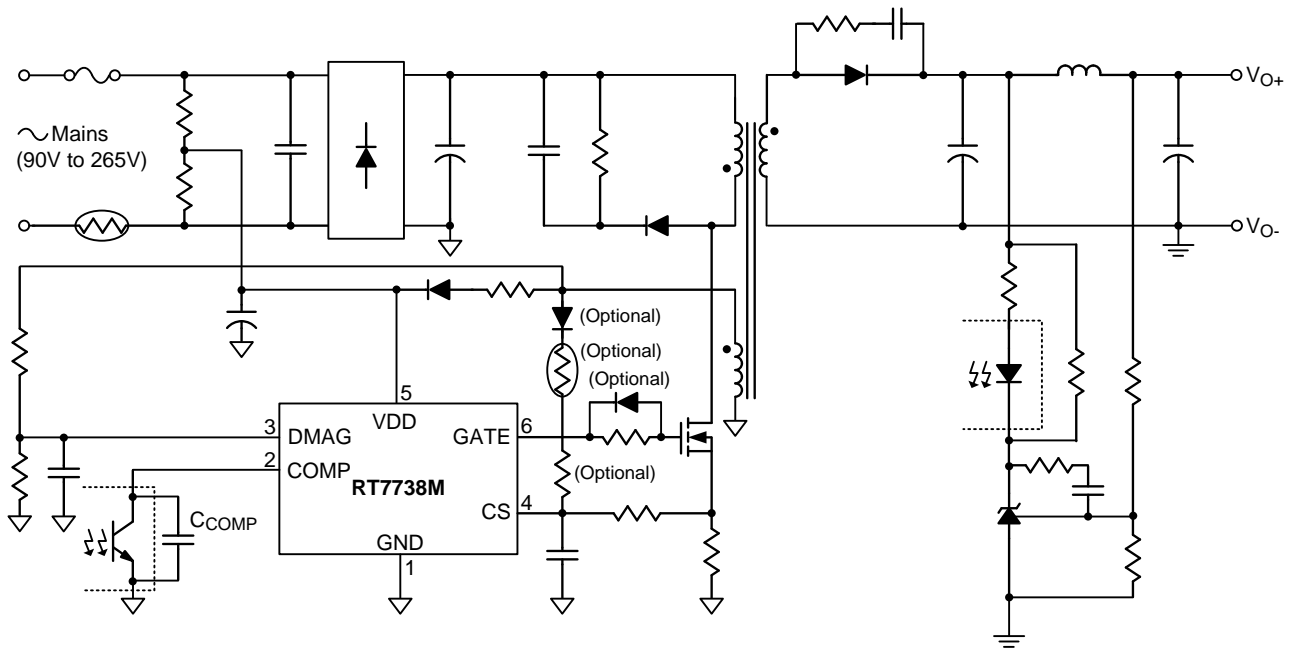

Typical Operating Characteristics

V_{TH_ON} vs. Temperature

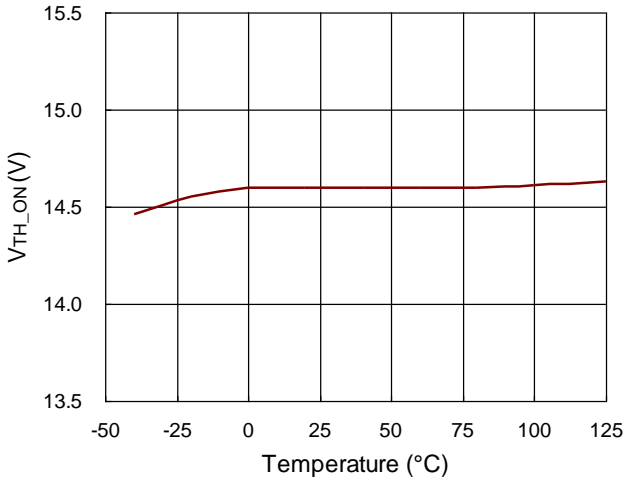

V_{TH_OFF} vs. Temperature

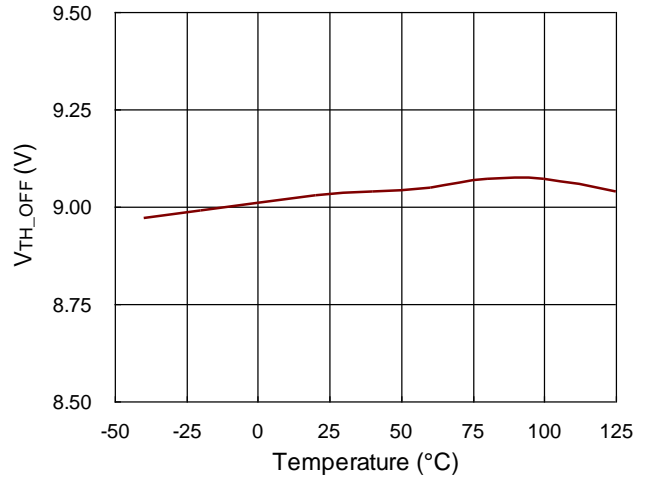

V_{OVP} vs. Temperature

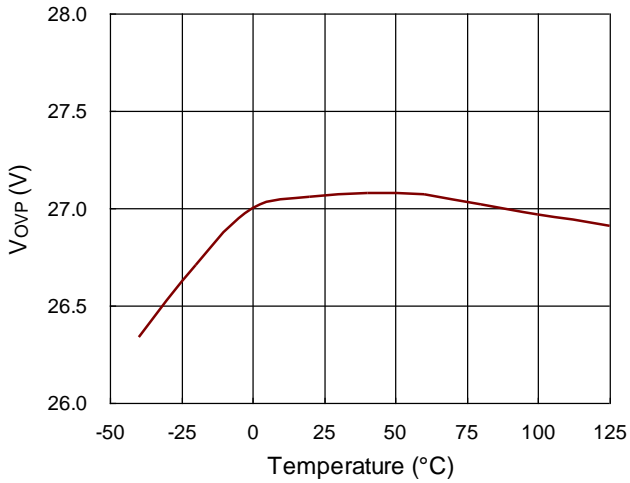

V_{DD_ET} vs. Temperature

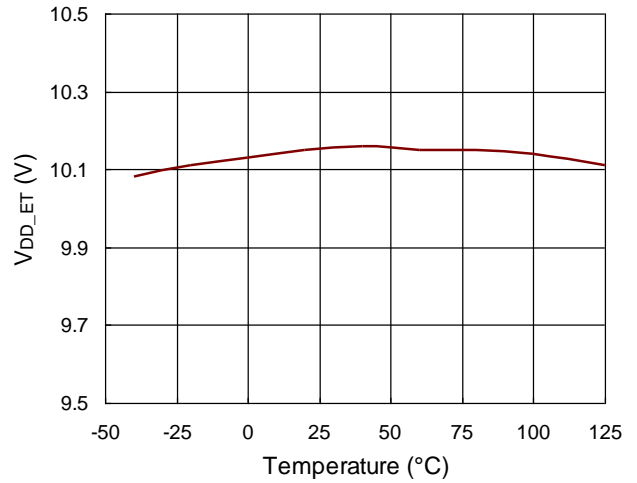

V_{DD_ED} vs. Temperature

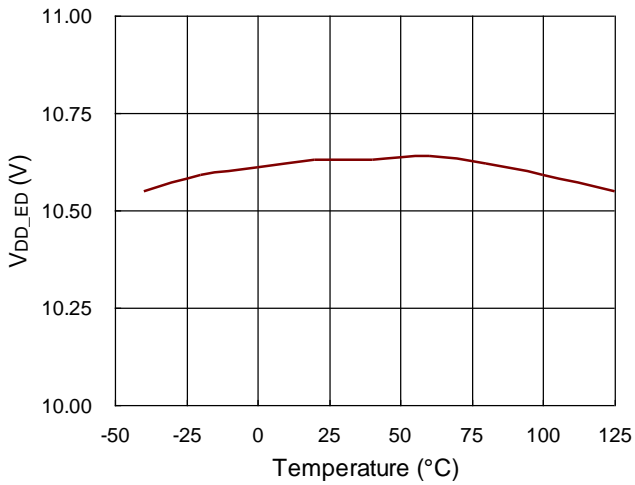

I_{DD_ST} vs. VDD

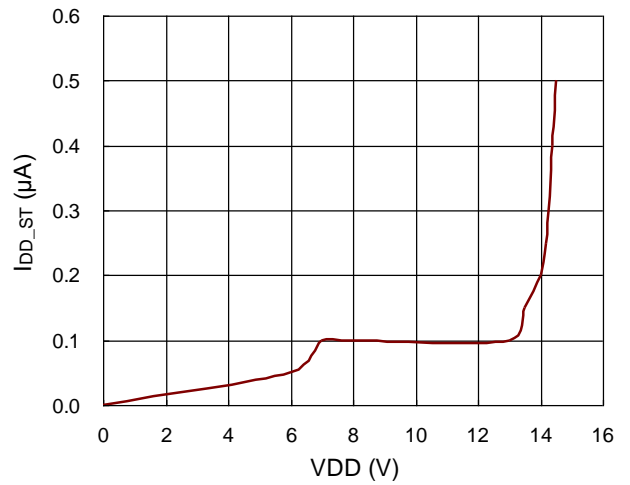

I_{DD_ST} vs. Temperature

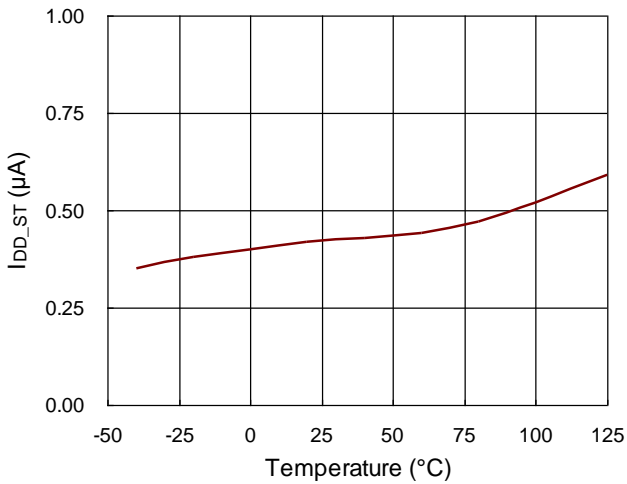

I_{DD_LH} vs. Temperature

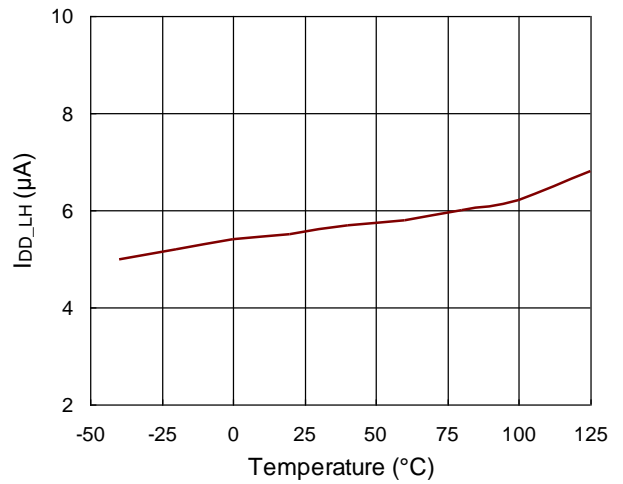

V_{DD_LH} & V_{LH_OFF} vs. Temperature

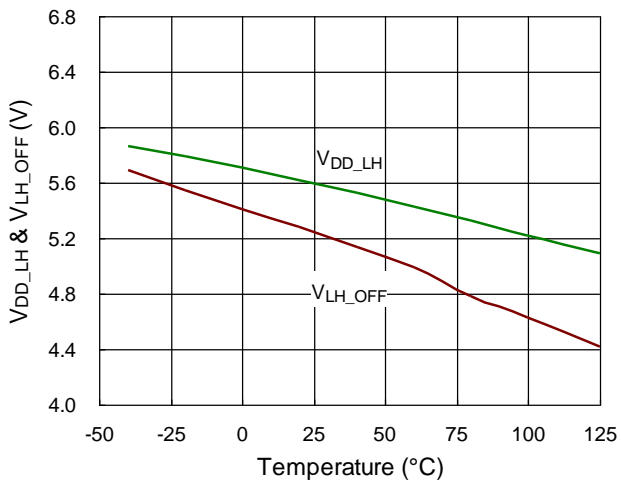

I_{DD_AMP} vs. Temperature

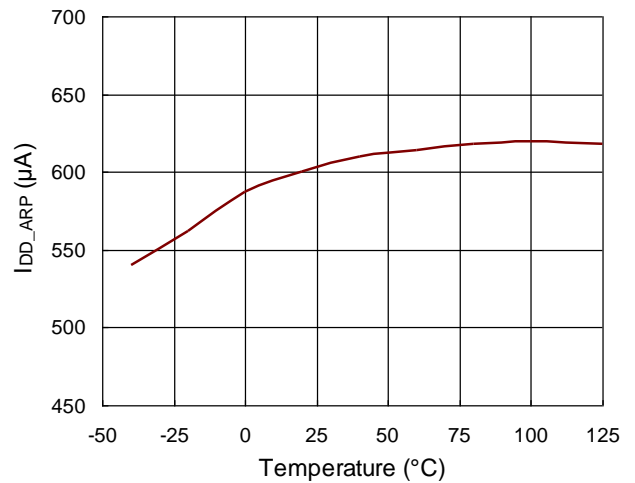

I_{DD_OP1} vs. Temperature

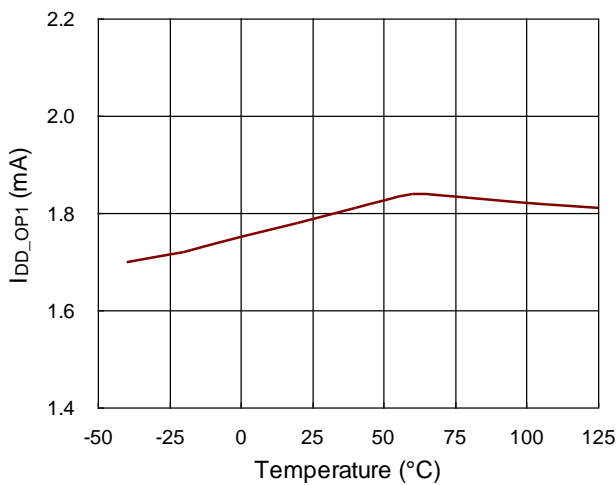

I_{DD_OP2} vs. Temperature

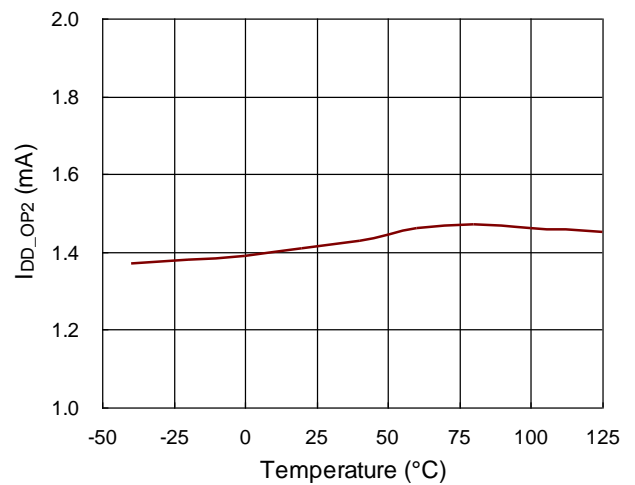

f_{osc} vs. VDD

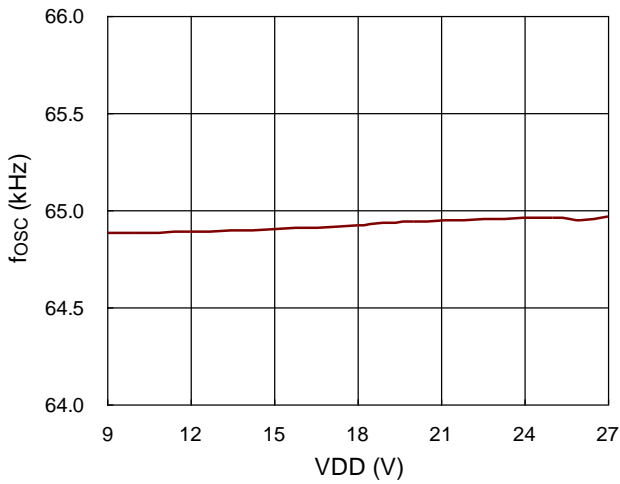

f_{osc} vs. Temperature

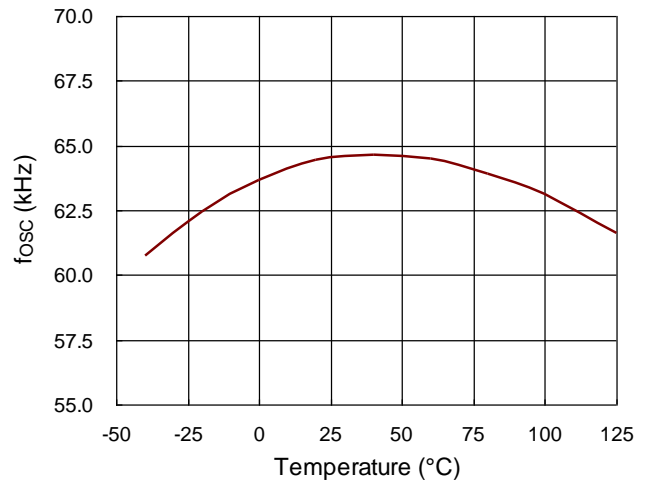

T_{ON_MAX} vs. Temperature

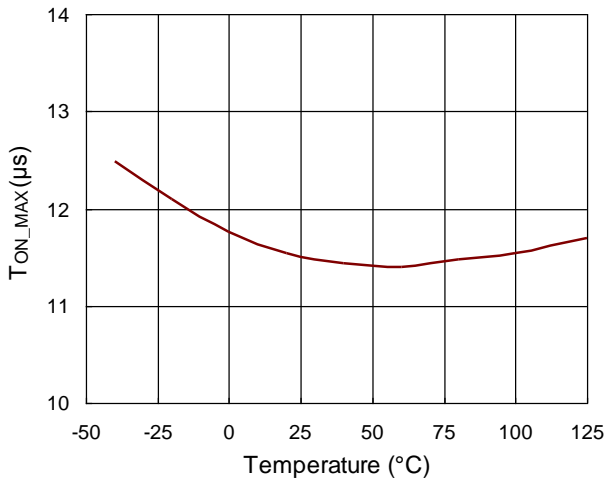

f_{GM_MIN} vs. Temperature

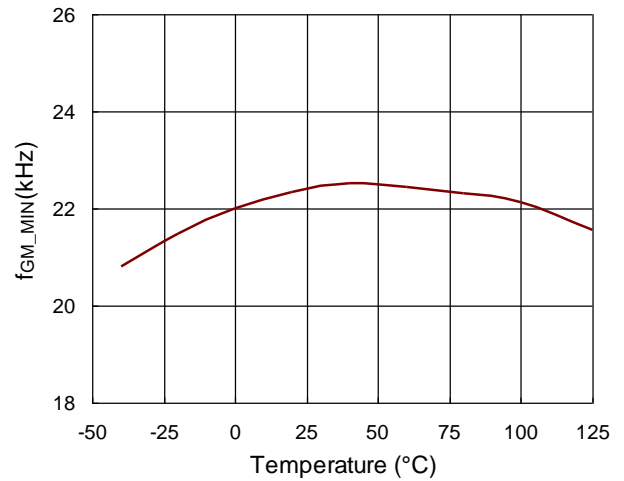

V_{COMP_OP} vs. Temperature

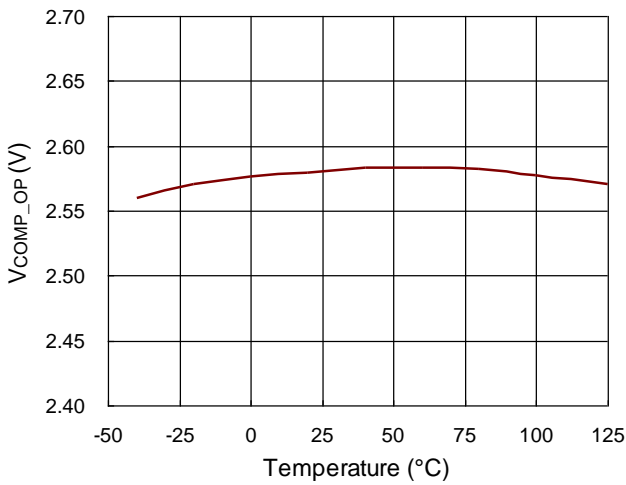

I_{ZERO} vs. Temperature

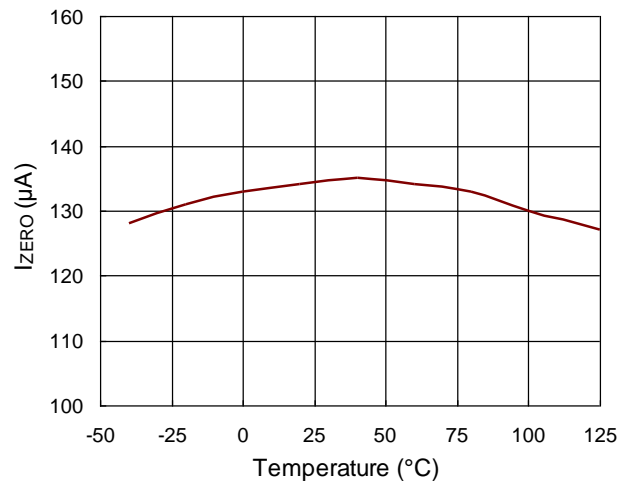

T_{OLP} vs. Temperature

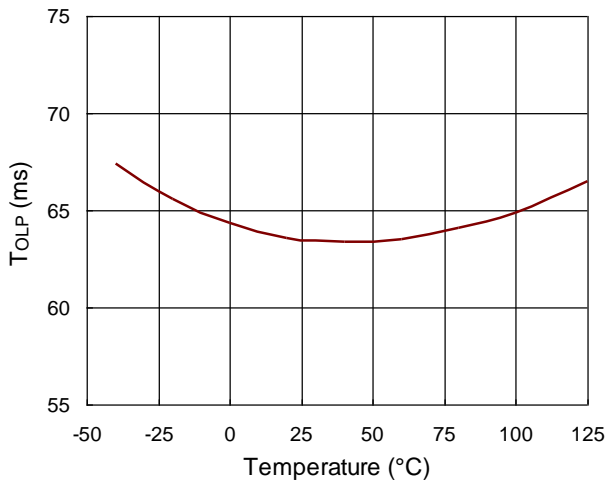

V_{CS_MAX} vs. Temperature

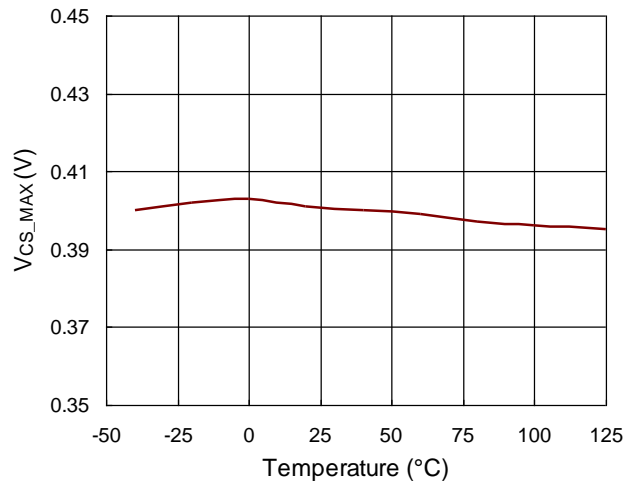

T_{LEB} vs. Temperature

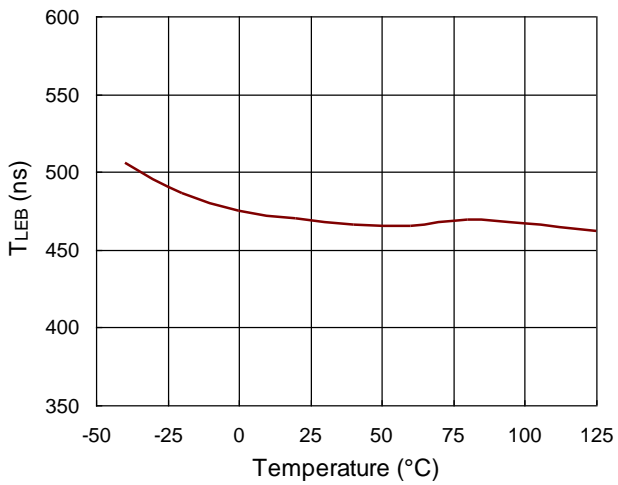

V_{CLAMP} vs. Temperature

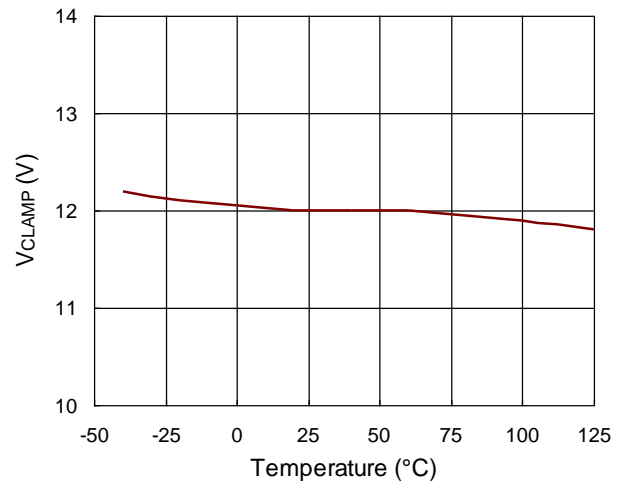

V_{SRSP_TH} vs. Temperature

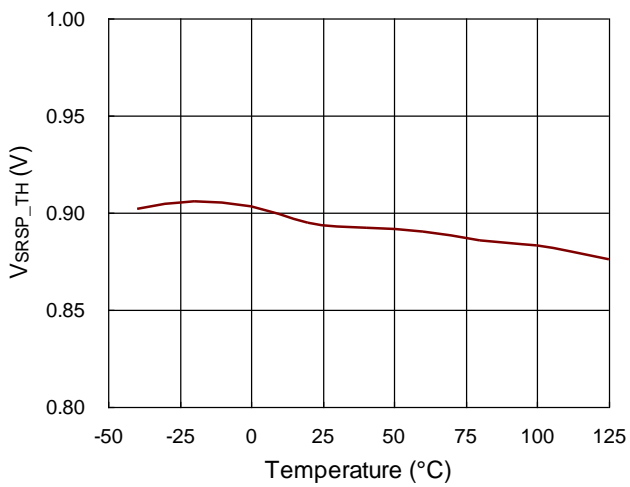

V_{OTP_TH} vs. Temperature

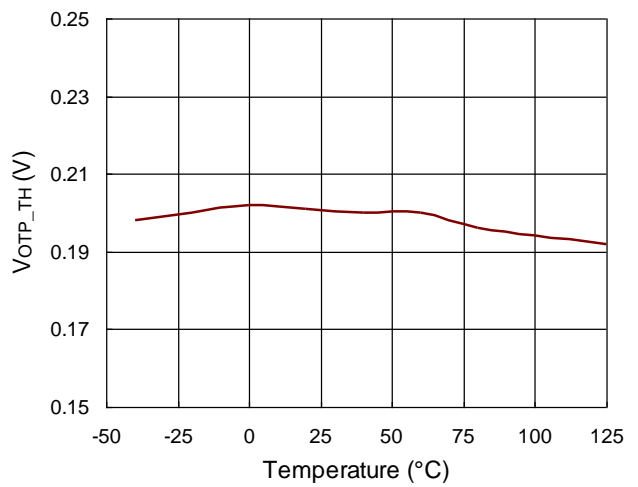

T_R vs. Temperature

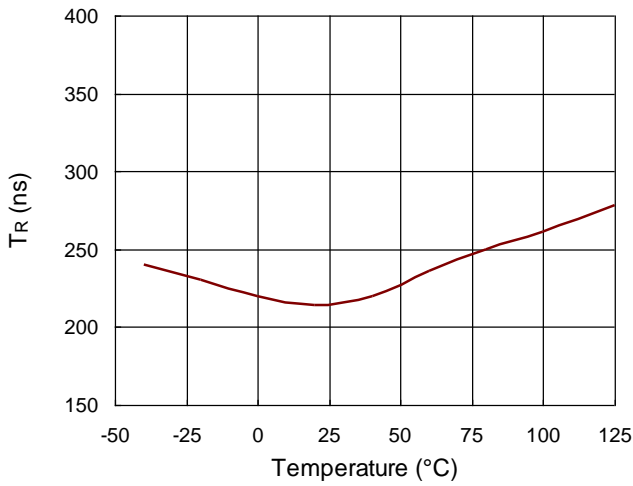

T_F vs. Temperature

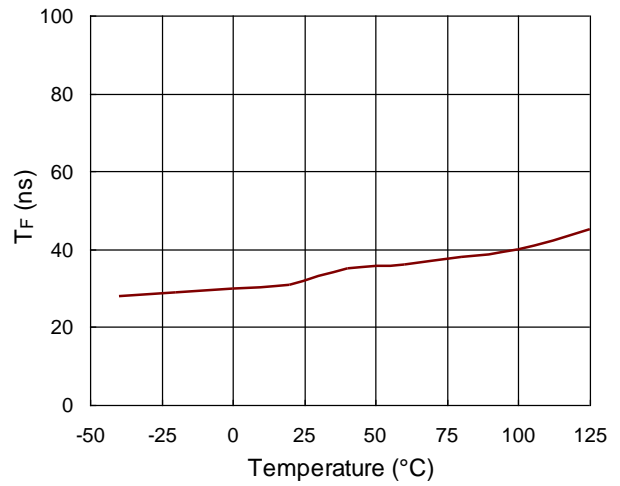

V_{DMAG_OVP} vs. Temperature

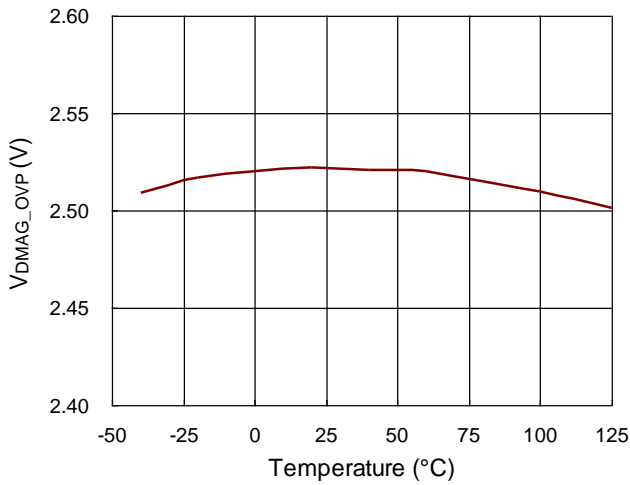

V_{DMAG_UVP} vs. Temperature

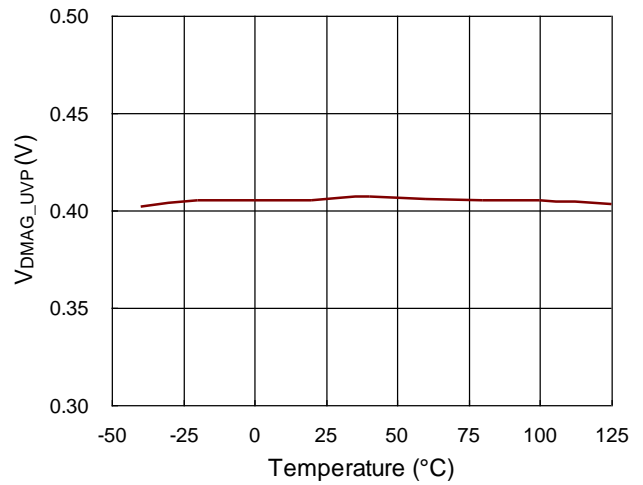

T_{BK_OVP} vs. Temperature

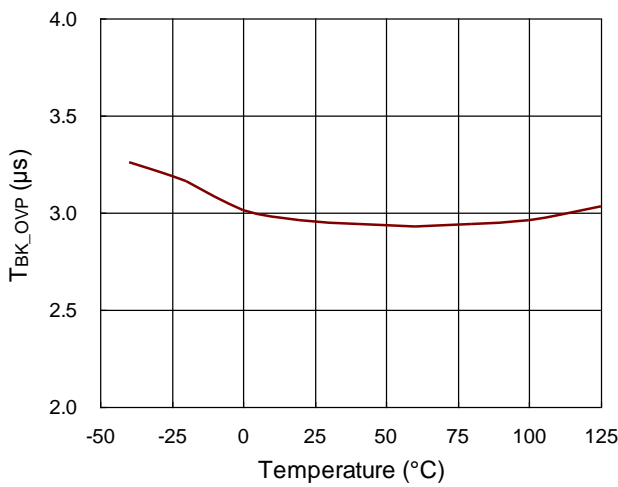

T_{D_OSP} vs. Temperature

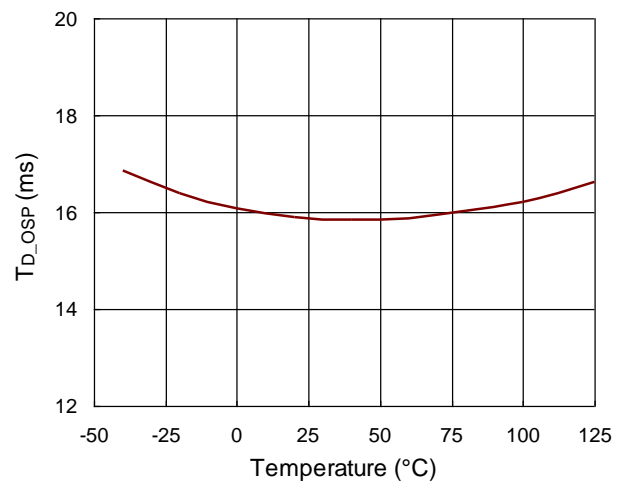

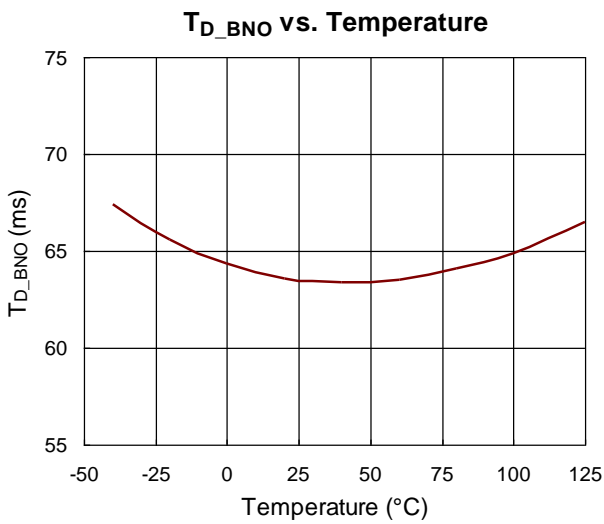
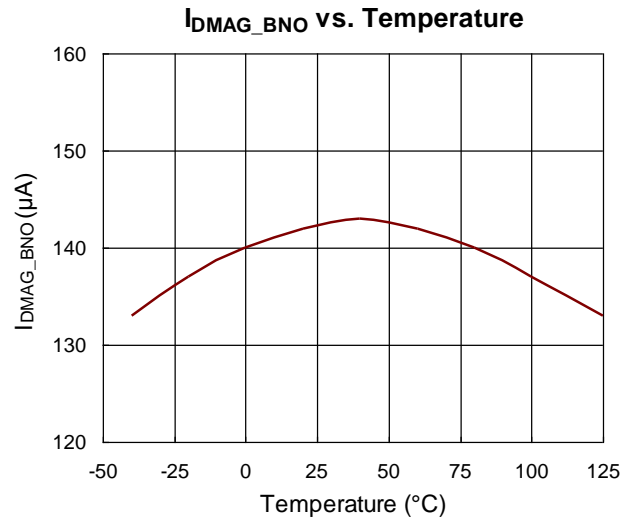
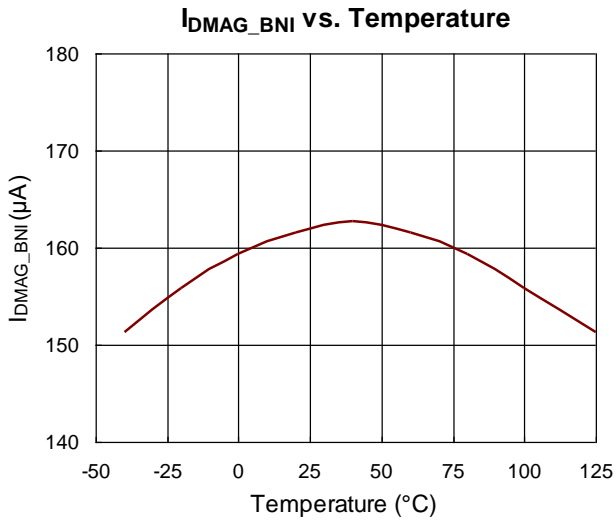

Application Information

The RT7738M is a multi-mode PWM flyback controller. The system automatically converts between constant frequency CCM and valley switching mode according to load conditions. As load decreases, the controller enters green mode, burst mode, and VDD holdup mode. The automatic multi-mode switching optimizes the product performance under different load conditions. To meet the stringent trend toward performance, the RT7738M is the best choice for product designers.

Programmable Propagation Delay Time Compensation Function

The RT7738M provides programmable propagation delay time compensation function, as shown in Figure 1. The RT7738M outputs a propagation delay time compensation current on the CS pin by gain. Product designers can compensate the propagation delay time differences caused by different input voltages by adjusting the propagation delay time compensation resistor (R_{PD}) to keep the same output current under different input voltages and accurate over-load protection.

In the beginning of propagation delay time compensation function setting, designers could set R_{PD} = 470Ω, and C_{RC} = 100pF. In Figure 2, the ideal output current should be the same as curve (1). No matter under high line or low line, the output current keeps the same. However, the propagation delay time varies OLP curve under different input voltages according to different designs of transformer inductance, parasitic capacitance of MOSFET, series resistance on the GATE of MOSFET. If the OLP curve is like curve (2), designers should increase the resistance of R_{PD}; if the OLP curve is like curve (3), designers should increase the capacitance of C_{RC}. Designers optimize the OLP curve through propagation delay time compensation to keep the same output current under different input voltages.

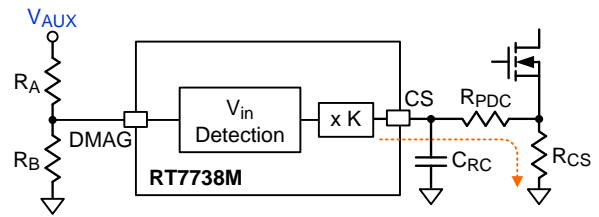

Figure 1. Function Block Diagram of Propagation Delay Time Compensation

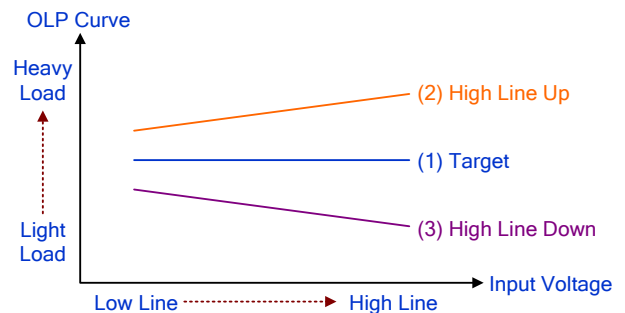

Figure 2. Curve Chart of OLP

External Over-Temperature Protection

The RT7738M implements external arbitrary over-temperature protection by CS pin. Designer can design arbitrary OTP via constant voltage source (VAUX_{Clamp}), fast diode and the divided resistors on CS pin, as shown in Figure 3. The constant voltage source is sensing by auxiliary voltage at GATE off, and the divided resistors are NTC resistor (R_{NTC}), setting resistor (R_{SET}), resistor of propagation delay compensation (R_{PD}) and current sense resistor (R_{CS}). When temperature is higher, the resistance of NTC resistor becomes small. The sampling voltage of divided resistors on CS pin during GATE off exceeds the V_{OTP_TH} trip level, and then after delay time T_{D_OTP} the controller will be shut down and cease switching. Until the OTP is released, the controller resumes operation. The design equation is :

$$V_{OTP_TH} = \left[(V_O + V_F) \times \frac{N_A}{N_S} - V_{F_OTP} \right] \times \frac{R_{PD} + R_{CS}}{R_{NTC_OTP} + R_{SET} + R_{PD} + R_{CS}}$$

Where R_{NTC_OTP} is the NTC resistance at over-temperature.

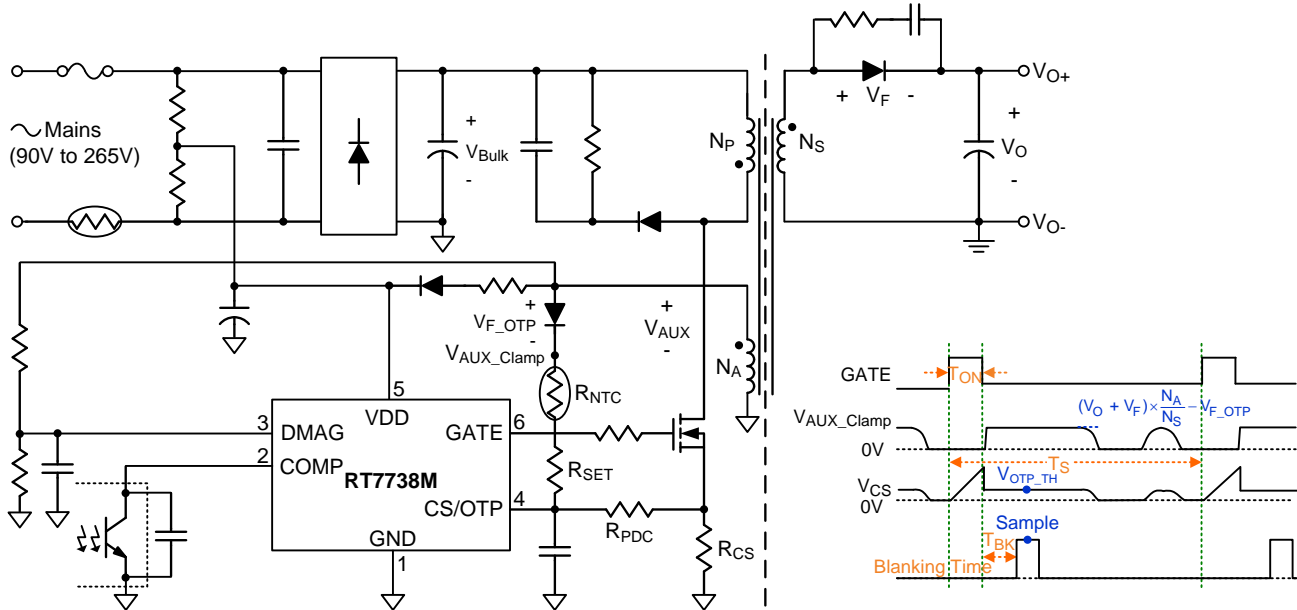

Figure 3. Application Circuit of External Over-Temperature Protection

SmartJitter™ Technology

The RT7738M applies RICHTEK proprietary SmartJitter™ technology.

In order to reduce switching loss for lower power consumption during light load or no load, general PWM controllers have green mode function.

The output power equation is :

$$P_{O_DCM}(V_{COMP}) = \frac{1}{2} \times L_p \times \left(\frac{x_1 \times V_{COMP}}{R_{CS}} \right)^2 \times f_s (V_{COMP}) \times \eta$$

Where L_p is the magnetizing inductance of the transformer, R_{CS} is the current sense resistor, V_{COMP} is the feedback voltage of the COMP pin. f_s is the switching frequency of the power switch, η is the conversion efficiency, and x_1 is a constant coefficient.

Output power is a function of feedback voltage V_{COMP} .

Frequency jittering technique is typically used to improve EMI problems in general PWM controllers, and the frequency jittering period is based on PWM switching frequency.

When the system enters green mode, a output power relationship is formed between the feedback voltage V_{COMP} and the PWM switching frequency, and a new stable equilibrium point is eventually reached after back-and-forth adjustments. It is mutually-affected by V_{COMP} and PWM switching frequency and limits the frequency jittering. As a result, EMI improvement function worsens, as show in Figure 4.

The innovative SmartJitter™ technology not only helps reduce EMI emissions of SMPS when the system enters green mode, but also eliminates output jittering ripple.

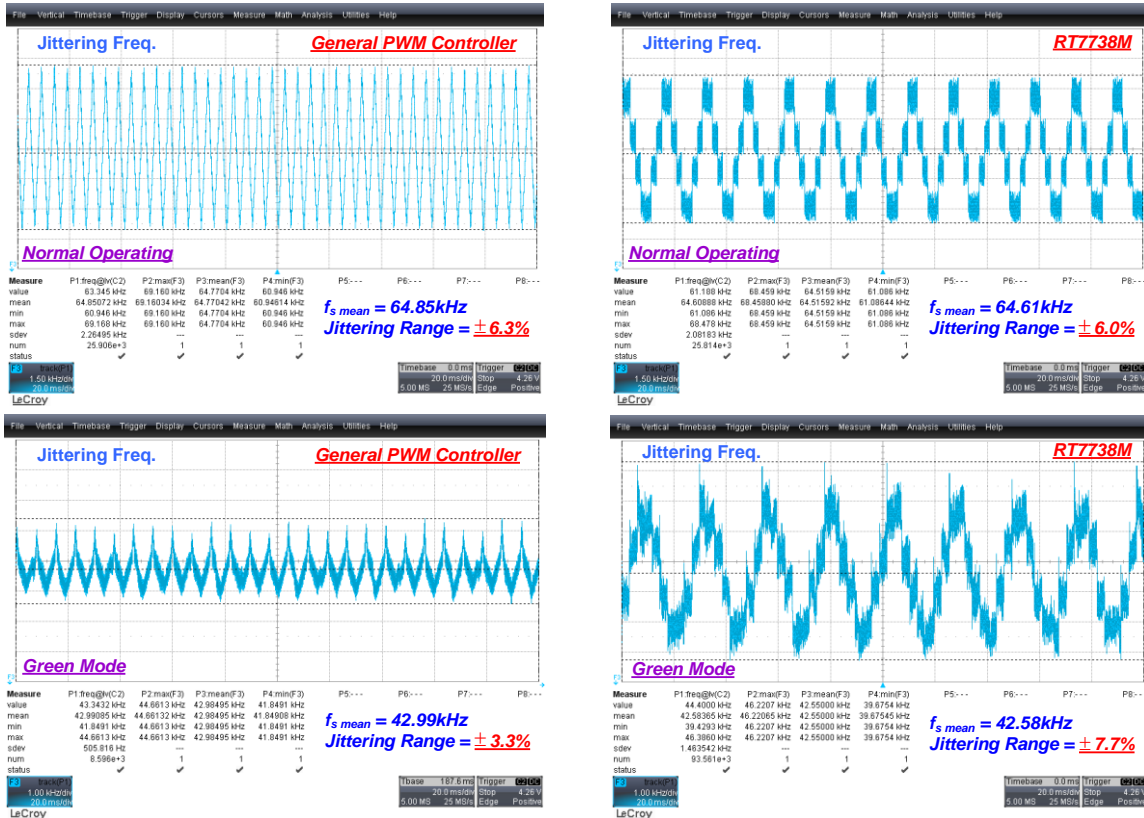

Figure 4. Frequency Jittering Range During Green Mode : General PWM Controller vs. RT7738M

DMAG Pin Resistance Setting

When the MOSFET turns on, the voltage of auxiliary winding is negative, and the clamping circuit outputs a clamp current to clamp the DMAG voltage at 0.1V. The clamping current is proportional to the input voltage. The clamping current is proportional to the input voltage. The RT7738M features DMAG threshold-on current (I_{DMAG_BNI}), and DMAG under-current protection threshold (I_{DMAG_BNO}). Designers can indirectly design bulk capacitor Brown-in ($V_{Bulk_Brown-in}$) and Brown-out ($V_{Bulk_Brown-out}$) by adjusting R_A and R_B on the DMAG pin, as shown in Figure 5.

When one of Brown-in and Brown-out is set, others are set proportionally.

The bulk capacitor input voltage Brown-out ($V_{Brown-out}$) is :

$$V_{Bulk_Brown-out} = \frac{V_{Bulk_Brown-in} \times I_{DMAG_BNO}}{I_{DMAG_BNI}}$$

When the MOSFET turns off, the DMAG pin detects the output voltage according to the ratio of auxiliary and secondary-side turns, and the series resistors,

R_A and R_B , on the auxiliary winding as shown in Figure 5. The RT7738M provides DMAG over-voltage protection, and designers can indirectly design output OVP (V_{O_OVP}) by DMAG OVP (V_{DMAG_OVP}) :

$$\begin{cases} \frac{V_{Bulk_Brown-in} \times N_A}{N_p} + 0.1}{R_A} + \frac{0.1}{R_B} = I_{DMAG_BNI} \\ \frac{(V_{O_OVP} + V_F) \times N_A}{N_s} \times \frac{R_B}{R_A + R_B} = V_{DMAG_OVP} \end{cases}$$

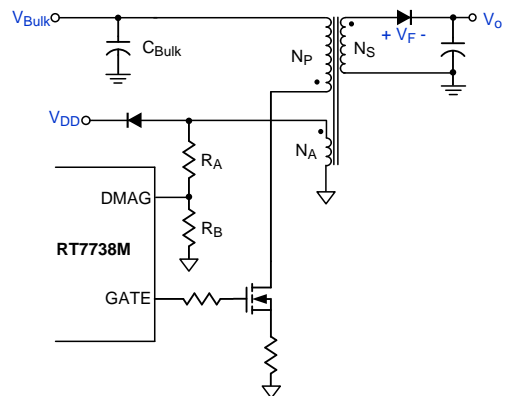

Figure 5. Design DMAG Pin Resistance

Adaptive Blanking Time

When the MOSFET turns off, the leakage inductance of the transformer and parasitic capacitance (C_{oss}) of MOSFET induce resonance waveform on the DMAG pin, as shown in Figure 6. The resonance waveform makes the controller false trigger the DMAG OVP (V_{DMAG_OVP}) which affects the accuracy of output OVP (V_{O_OVP}), and it may cause the controller operate in unstable condition. As load increases, the resonance time also increases. It is recommended to add 10pF to 47pF bypass capacitor to avoid noise false triggering on DMAG pin. The bypass capacitor should be as close to DMAG pin as possible. The bigger bypass capacitor maybe causes some phase shift on DMAG waveform, so RT7738M maybe doesn't turn on at exact valley point.

The RT7738M provides adaptive blanking time to prevent DMAG OVP from being false triggered. The blanking time (T_{BK_OVP}) varies with maximum current limit of the CS pin (V_{CS_PK}), and the blanking time can be calculated by the following formula :

$$T_{BK_OVP} = 2\mu s + V_{CS_PK} \times 2.5 (\mu s/V)$$

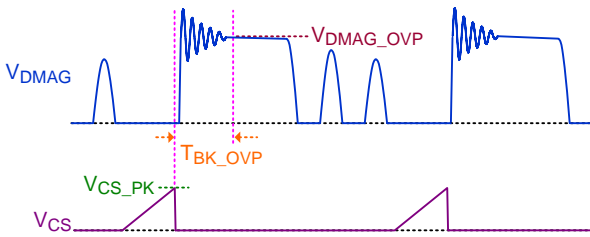

Figure 6. Resonance Waveform on the DMAG Pin

Start-Up Circuit

To minimize power loss, it's recommended to connect the start-up circuit to the bleeding resistors. It's power saving and also could reset latch mode protection quickly. Figure 7 shows I_{DD_Avg} vs. R_{Bleeding} curve. Users can apply this curve to design the adequate bleeding resistors.

In order to prolong turn-off period and minimize the power loss and thermal rising during hiccup, the controller is designed to have smaller sinking current during entering auto-recovery protection, I_{DD_ARP}. Therefore, the start-up current at maximum AC line input voltage must be smaller than I_{DD_ARP} (I_{DD_ARP(min)} = 400μA). Otherwise, when the controller enters auto-recovery protection, the V_{DD} capacitor won't be dropped down to V_{TH_OFF} by IC's sinking current and then restart. The controller behaves like latch protection or triggers the SCR of V_{DD}.

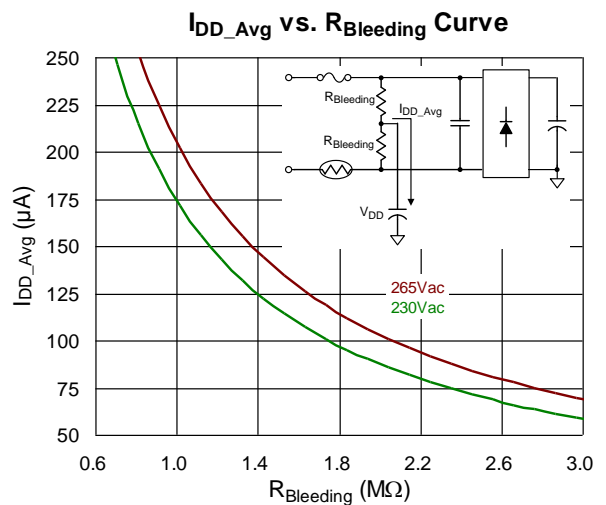
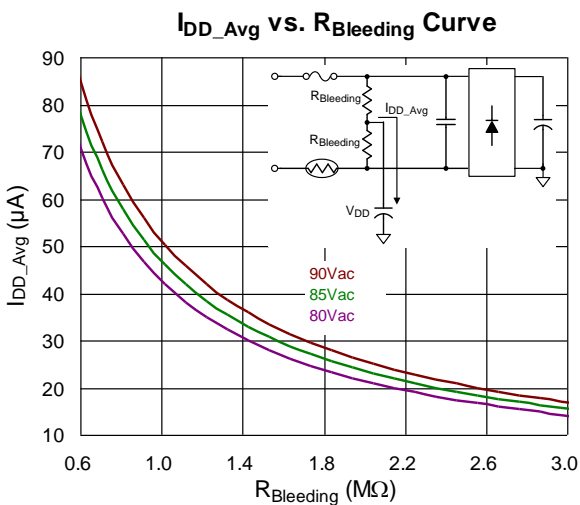

Figure 7. I_{DD_Avg} vs. R_{Bleeding} Curve

VDD Discharge Time in Auto Recovery Mode

Figure 8 shows the V_{DD} and V_{GATE} waveforms during an auto recovery protection (e.g., OLP). In this mode, the start-up resistors, V_{DD} sinking current and V_{DD} decoupling capacitor will affect the restart time. The V_{DD} voltage discharge time t_{D_Discharge} can be calculated by the following equation :

$$t_{D_Discharge} = \frac{C_{VDD} \times (V_{DD_DIS} - V_{TH_OFF})}{I_{DD_ARP} - I_{ST}}$$

Where the C_{VDD} is the V_{DD} decoupling capacitor, the V_{DD_DIS} is the initial V_{DD} voltage after entering the auto recovery mode, the V_{TH_OFF} (9V typ.) is the falling UVLO voltage threshold of the controller, the I_{DD_ ARP} (550μA typ.) is the sinking current of the V_{DD} pin in the auto recovery mode, and I_{ST} is the start-up current of the power system.

Please note that the start-up current at high input voltage must be smaller than the I_{DD_ ARP}. Otherwise, the V_{DD} voltage can't reach the V_{TH_OFF} to activate the next start-up process after an auto recovery protection. Therefore, the system behavior resembles the behavior of latch mode.

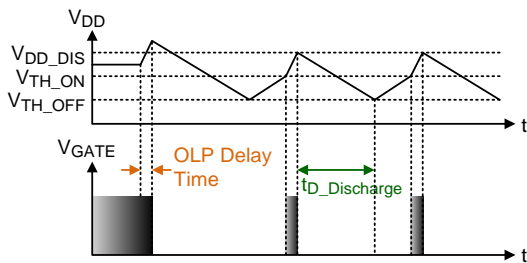

Figure 8. Auto Recovery Mode (e.g., OLP)

VDD Holdup Mode

The V_{DD} holdup mode is only designed to prevent V_{DD} from decreasing to the turn-off threshold voltage, V_{TH_OFF}, under light load or load transient. Compare to burst mode, the V_{DD} holdup mode brings higher switching. Hence, it is highly recommended that the system should avoid operating at this mode during light load or no load conditions.

Output Short Protection

The RT7738M implements output short protection by detecting output signal of DMAG pin after delay time (T_{D_ OSP}). It can minimize the power loss and temperature during output short, especially at high line input voltage.

Resistors on GATE Pin

In Figure 9, R_G is applied to alleviate ringing spike of gate drive loop in typical application circuits. The value of R_G must be considered carefully with respect to EMI and efficiency for the system.

The built-in internal discharge resistor R_{ID} in parallel with GATE pin prevents the MOSFET from any uncertain condition. If the connection between the GATE pin and the Gate of the MOSFET is disconnected, the MOSFET will be false triggered by the residual energy through the Gate-to-Drain parasitic capacitor C_{GD} of the MOSFET and the system will be damaged. Therefore, it's highly recommended to add an external discharge-resistor R_{ED} connected between the Gate of MOSFET and GND terminals. The energy through the C_{GD} is discharged by the external discharge-resistor to avoid MOSFET false triggering.

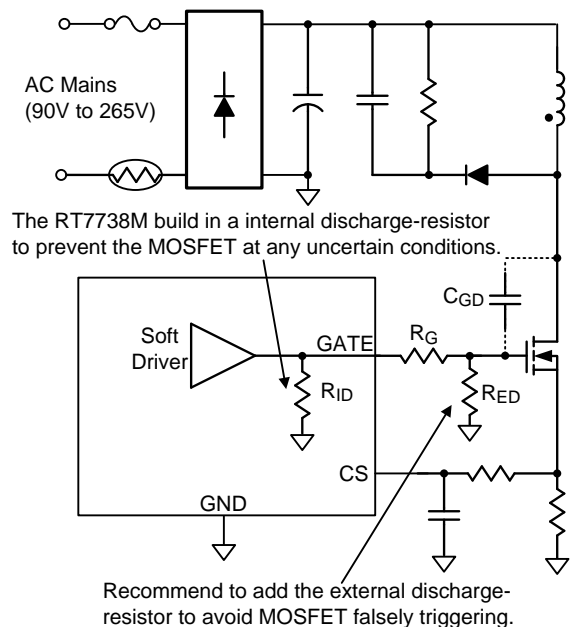

Figure 9. Resistors on Gate Pin

Feedback Resistor

In order to enhance light load efficiency, the loss of the feedback resistor in parallel with photo-coupler is reduced, as shown in Figure 10. Due to small feedback resistor current, shunt regulator selection (e.g. TL-431) and minimum regulation current design must be considered carefully to make sure it's able to regulate under low cathode current.

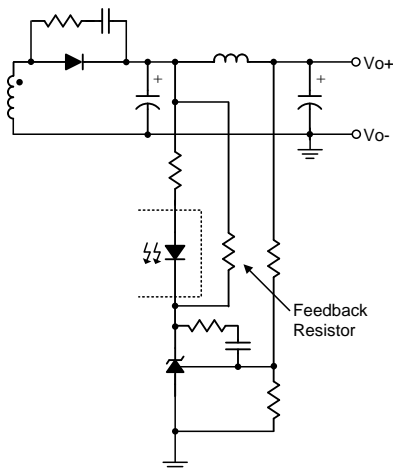

Figure 10. Feedback Resistor

Negative Voltage Spike on Each Pin

Negative voltage (<-0.3V) to the controller pins will cause substrate injection and lead to controller damage or circuit false triggering. For example, the negative spike voltage at the CS pin may come from improper PCB layout or inductive current sense resistor. Therefore, it is highly recommended to add an R-C filter to avoid the CS pin damage, as shown in Figure 11. Proper PCB layout and component selection should be considered during circuit design.

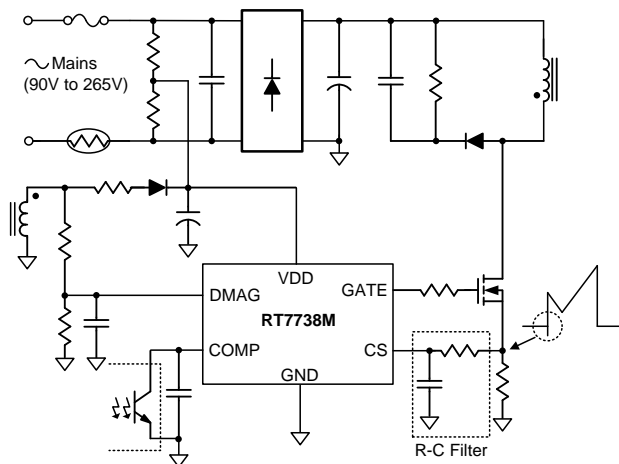

Figure 11. R-C Filter on CS Pin

Internal Over-Temperature Protection

The RT7738M provides OTP function to prevent permanent damage. It is not recommended to apply this function to accurate temperature control.

When the IC turns on, the controller detects around temperature before it starts switching. If the temperature is higher than T_{OTP_INTH} (typ. 130°C), the controller triggers OTP, and there is no output signal. If the temperature is lower than T_{OTP_INTH} , the controller starts operation and the OTP threshold is automatically set to T_{OTP_STTH} (typ.140°C), which means when the controller starts switching, the OTP threshold is T_{OTP_STTH} .

When the controller triggers OTP, the controller will be shut down and cease switching. At the same time, V_{DD} drops below V_{DD} off threshold V_{TH_OFF} , the controller enters hiccup mode.

Thermal Considerations

For continuous operation, do not exceed absolute maximum junction temperature. The maximum power dissipation depends on the thermal resistance of the IC package, PCB layout, rate of surrounding airflow, and difference between junction and ambient temperature. The maximum power dissipation can be calculated by the following formula :

$$P_{D(MAX)} = (T_{J(MAX)} - T_A) / \theta_{JA}$$

where $T_{J(MAX)}$ is the maximum junction temperature, T_A is the ambient temperature, and θ_{JA} is the junction to ambient thermal resistance.

For recommended operating condition specifications, the maximum junction temperature is 125°C. The junction to ambient thermal resistance, θ_{JA} , is layout dependent. For SOT-23-6 package, the thermal resistance, θ_{JA} , is 260.7°C/W on a standard JEDEC 51-3 single-layer thermal test board. The maximum power dissipation at $T_A = 25^\circ\text{C}$ can be calculated by the following formula :

$$P_{D(MAX)} = (125^\circ\text{C} - 25^\circ\text{C}) / (260.7^\circ\text{C/W}) = 0.38\text{W for SOT-23-6 package}$$

The maximum power dissipation depends on the operating ambient temperature for fixed $T_{J(MAX)}$ and thermal resistance, θ_{JA} . The derating curve in Figure 12 allows the designer to see the effect of rising ambient temperature on the maximum power dissipation.

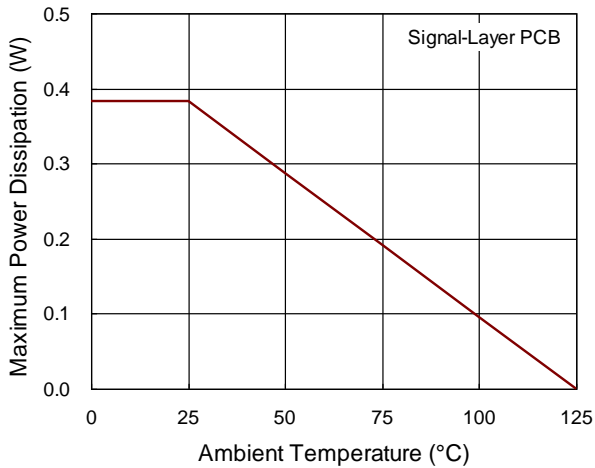

Figure 12. Derating Curve of Maximum Power Dissipation

Layout Consideration

A proper PCB layout can abate unknown noise interference and EMI issue in the switching power supply. Please refer to the guidelines when you want to design PCB layout for switching power supply :

- ▶ The current path (1) through bulk capacitor, transformer, MOSFET, R_{CS} returns to bulk capacitor is a high frequency current loop. It must be as short as possible to decrease noise coupling and keep away from other low voltage traces, such as IC control circuit paths, especially.
- ▶ The path (2) of the RCD snubber circuit is also a high switching loop. Keep it as small as possible.
- ▶ Separate the ground traces of bulk capacitor(a), MOSFET(b), auxiliary winding(c) and IC control circuit(d) for reducing noise, output ripple and EMI issue. Connect these ground traces together at bulk capacitor ground (a). The areas of these ground traces should be large enough.
- ▶ Place the bypass capacitor as close to the controller as possible.
- ▶ In order to reduce reflected trace inductance and EMI, minimize the area of the loop connecting the secondary winding, output diode and output filter capacitor. In additional, apply sufficient copper area at the anode and cathode terminal of the diode for heatsinking.

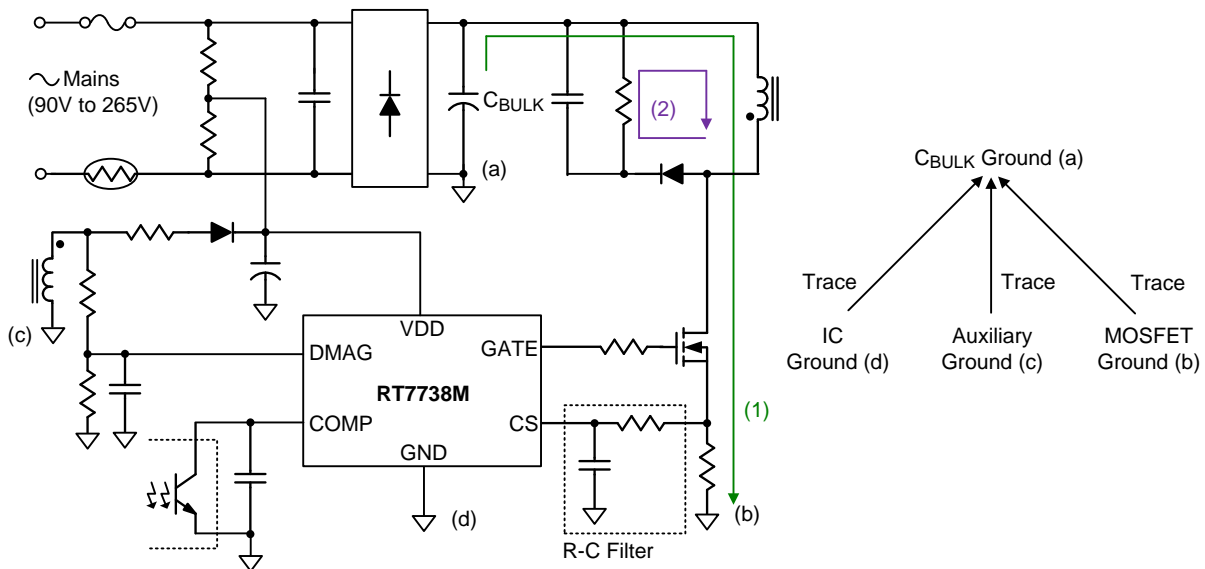
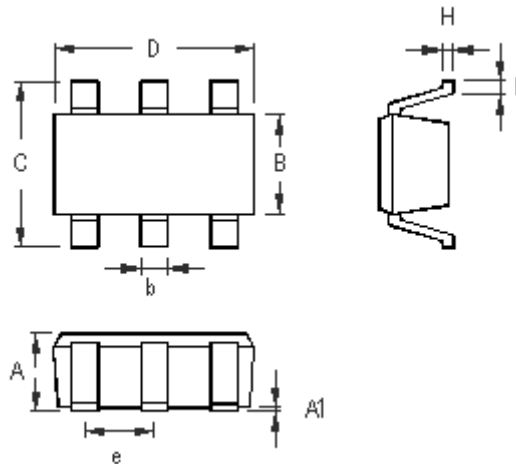

Figure 13. PCB Layout Guide

Outline Dimension



Symbol	Dimensions In Millimeters		Dimensions In Inches	
	Min	Max	Min	Max
A	0.889	1.295	0.031	0.051
A1	0.000	0.152	0.000	0.006
B	1.397	1.803	0.055	0.071
b	0.250	0.560	0.010	0.022
C	2.591	2.997	0.102	0.118
D	2.692	3.099	0.106	0.122
e	0.838	1.041	0.033	0.041
H	0.080	0.254	0.003	0.010
L	0.300	0.610	0.012	0.024

SOT-23-6 Surface Mount Package

Richtek Technology Corporation

14F, No. 8, Tai Yuen 1st Street, Chupei City

Hsinchu, Taiwan, R.O.C.

Tel: (8863)5526789

Richtek products are sold by description only. Richtek reserves the right to change the circuitry and/or specifications without notice at any time. Customers should obtain the latest relevant information and data sheets before placing orders and should verify that such information is current and complete. Richtek cannot assume responsibility for use of any circuitry other than circuitry entirely embodied in a Richtek product. Information furnished by Richtek is believed to be accurate and reliable. However, no responsibility is assumed by Richtek or its subsidiaries for its use; nor for any infringements of patents or other rights of third parties which may result from its use. No license is granted by implication or otherwise under any patent or patent rights of Richtek or its subsidiaries.

Copyright © 2014 Richtek Technology Corporation. All rights reserved. **RICHTEK** is a registered trademark of Richtek Technology Corporation.