

High Voltage Buck LED Driver with Dimming Control

General Description

The RT8406 is a current-mode LED driver supporting wide input voltage range from 10V to 65V. With internal adjustable operating frequency 65kHz and 130kHz, the size of the external inductor and input/output capacitors can be minimized at high operating frequency. High efficiency is achieved by a 100mV current sensing control. In addition, the RT8406 features low standby power. LED dimming control can be done from either analog or PWM signal and share the same pin. The RT8406 provides thermal shutdown to prevent the device from overheat. The RT8406 is available in the SOP-8 package.

Ordering Information

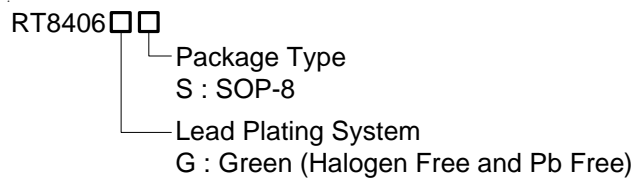

Note :

Richtek products are :

- ▶ RoHS compliant and compatible with the current requirements of IPC/JEDEC J-STD-020.
- ▶ Suitable for use in SnPb or Pb-free soldering processes.

Features

- Precise and Wide Dimming Range (0.5% to 100%)
- Low Standby Power Consumption
- High Input Voltage : VIN up to 65V
- Current-Mode PWM Control
- 65kHz/130kHz Adjustable Switching Frequency
- Analog and PWM Dimming Control and Share the Same Pin
- Under-Voltage Lockout
- Cycle-by-Cycle Current Limitation
- Thermal Shutdown
- Driver Capability : 350mA / -500mA
- RoHS Compliant and Halogen Free

Applications

- DC-DC LED Lighting Driver

Marking Information

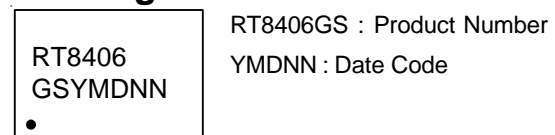

Pin Configuration

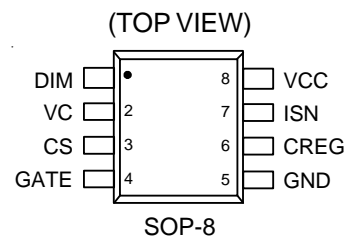

Typical Application Circuit

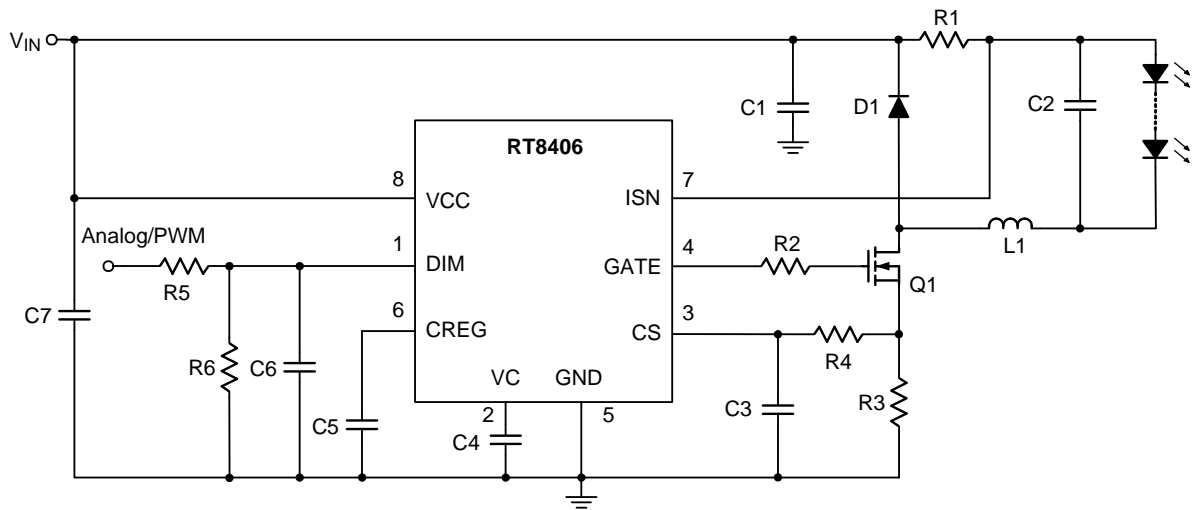

Suggested Component Values

C3 (nF)	C4 (nF)	C5 (μF)	C6 (μF)	C7 (μF)	R2 (Ω)	R5 (Ω)	R6 (Ω)
1	1	1	1	1	22	51k	510k

Switch Frequency	R4 (kΩ)
130kHz	1
65kHz	2

Functional Pin Description

Pin No.	Pin Name	Pin Function
1	DIM	Analog or PWM dimming control input.
2	VC	PWM loop compensation node.
3	CS	MOSFET current sense input.
4	GATE	Gate driver output for external MOSFET switch.
5	GND	Ground of the controller.
6	CREG	Regulator output.
7	ISN	LED current sense input. Voltage threshold between VCC and ISN is 100mV.
8	VCC	Supply voltage input. The controller will be enabled when VDD exceeds V _{TH_ON} and disabled when VDD is lower than V _{TH_OFF} .

Functional Block Diagram

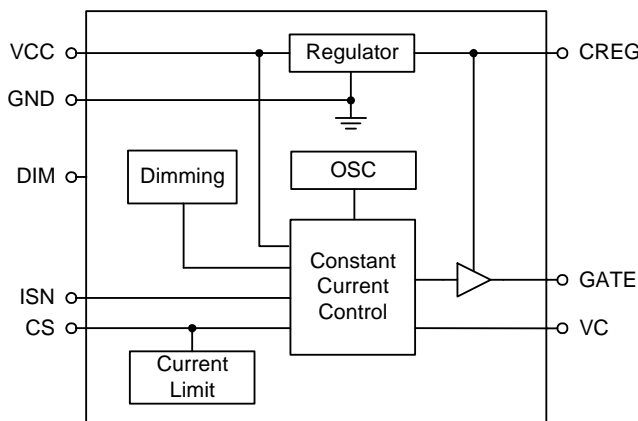

Operation

The RT8406 is a current mode PWM controller for Buck converter applications. With the fixed frequency and current-mode control scheme, the excellent line and load regulation can be obtained. Two operating frequencies, 65k and 130k Hz, can be set by the selection of resistance connected to CS pin. The control loop has a current sense amplifier which senses the voltage between the VCC and ISN pins and provides an output voltage at the VC pin. In normal operation, the GATE turns to high when the gate driver is set by the oscillator (OSC). Once the sensed power switch current exceeds the compensated VC pin voltage, a PWM comparator will reset the gate driver and then turns off the external power switch. In protection or abnormal operation, the compensated VC pin voltage could be pulled low. When the VC voltage is lower than 0.75V (typ.), the PWM switching signal for GATE will be terminated.

The current through the sense resistor is set by the signal at DIM pin and the sense resistance. The voltage across the sense resistor can be programmed by the analog or PWM signal on the DIM pin with good dimming linearity. The Max. current sense threshold voltage (100mV typ.) can be obtained with DIM pin voltage greater than dimming high threshold voltage (V_{DIM_H} , 2.8V typ.). The sense threshold is intentionally forced to zero by an internal comparator when the DIM pin voltage is lower than dimming

disabled voltage (V_{DIM_DIS} , 0.25V typ.). When the DIM pin voltage rises to be higher than dimming enabled voltage (V_{DIM_EN} , 0.35V typ.), the sense threshold turns to positive and makes GATE turn on.

To reduce the power consumption in shutdown, the RT8406 provides standby mode operation. When the DIM pin voltage is lower than V_{DIM_DIS} and the duration exceeds 1s (typ.), the CREG pin voltage and VC voltage will both decrease to 0V to disable most control functions. That means RT8406 enters standby mode. When the DIM pin voltage rises to be higher than V_{DIM_EN} , the GATE will start to switch after the CREG pin voltage exceeds CREG UV (7.8V typ.) and VC voltage exceeds 0.75V. That means RT8406 returns to normal operation.

The RT8406 provides protection functions which include input voltage under-voltage lockout (UVLO), over-temperature protection (OTP), and cycle-by-cycle current limitation to prevent abnormal situations.

Absolute Maximum Ratings (Note 1)

- VCC, ISN to GND ----- -0.3V to 72V
- CREG, GATE to GND ----- -0.3V to 20V
- DIM, VC, CS to GND ----- -0.3V to 7.5V
- Power Dissipation, P_D @ T_A = 25°C
 - SOP-8 ----- 0.53W
- Package Thermal Resistance (Note 2)
 - SOP-8, θ_{JA} ----- 188°C/W
 - SOP-8, θ_{JC} ----- 47°C/W
- Junction Temperature ----- 150°C
- Lead Temperature (Soldering, 10 sec.) ----- 260°C
- Storage Temperature Range ----- -65°C to 150°C
- ESD Susceptibility (Note 3)
 - HBM (Human Body Model) ----- 2kV

Recommended Operating Conditions (Note 4)

- Supply Input Voltage, VCC ----- 12V to 65V
- Junction Temperature Range ----- -40°C to 125°C
- Ambient Temperature Range ----- -40°C to 85°C

Electrical Characteristics

(V_{CC} = 12V, C_{IN} = 1μF, T_A = 25°C, unless otherwise specified)

Parameter	Symbol	Test Conditions	Min	Typ	Max	Unit
VCC Section						
Rising UVLO Threshold Voltage	V _{TH_ON}		9	10	11	V
Falling UVLO Threshold Voltage	V _{TH_OFF}		7	8	9	V
CREG UV			--	7.8	--	V
Supply Current	I _{VCC}		--	--	1.2	mA
Shutdown Current	I _{SD}		--	60	--	μA
Current Sense Section						
Input Current of ISN Pin	I _{ISN}	V _{ISN} = 60V	--	30	--	μA
Mean Current Sense Threshold Voltage		V _{CC} – ISN DIM = 3V	96	100	104	mV
Current Limit			175	210	--	mV
Dimming Section						
Dimming High Threshold Voltage	V _{DIM_H}		--	2.8	--	V
Dimming Enabled Voltage	V _{DIM_EN}		--	0.35	0.4	V
Dimming Disabled Voltage	V _{DIM_DIS}		0.19	0.25	--	V

Parameter	Symbol	Test Conditions	Min	Typ	Max	Unit
Timing Control Section						
High Switching Frequency	f _{SW_H}	R _{LP} = 1kΩ, C _{LP} = 680pF	110	130	150	kHz
Low Switching Frequency	f _{SW_L}	R _{LP} = 2kΩ, C _{LP} = 1nF	50	65	80	kHz
Leading Edge Blanking Time	t _{LEB}		100	150	200	ns
Maximum Duty Ratio	D _{MAX}		94	97	--	%
Gate Driving Section						
Rising Time	t _R	V _{CC} = 15V, C _L = 1nF (10%~90%)	--	40	70	ns
Falling Time	t _F	V _{CC} = 15V, C _L = 1nF (90%~10%)	--	25	50	ns
Gate Output Clamping Voltage	V _{CLAMP}	V _{CC} = 15V	8.5	10.25	12	V
Internal Pull Low Resistor	R _{GATE}	V _{CC} = 15V	--	40	--	kΩ

- Note 1.** Stresses beyond those listed under “Absolute Maximum Ratings” may cause permanent damage to the device. These are stress ratings only, and functional operation of the device at these or any other conditions beyond those indicated in the operational sections of the specifications is not implied. Exposure to absolute maximum rating conditions may affect device reliability.
- Note 2.** θ_{JA} is measured under natural convection (still air) at T_A = 25°C with the component mounted on a high effective-thermal-conductivity four-layer test board on a JEDEC 51-7 thermal measurement standard. θ_{JC} is measured at the exposed pad of the package.
- Note 3.** Devices are ESD sensitive. Handling precaution is recommended.
- Note 4.** The device is not guaranteed to function outside its operating conditions.

Typical Operating Characteristics

f_{sw_H} vs. Temperature

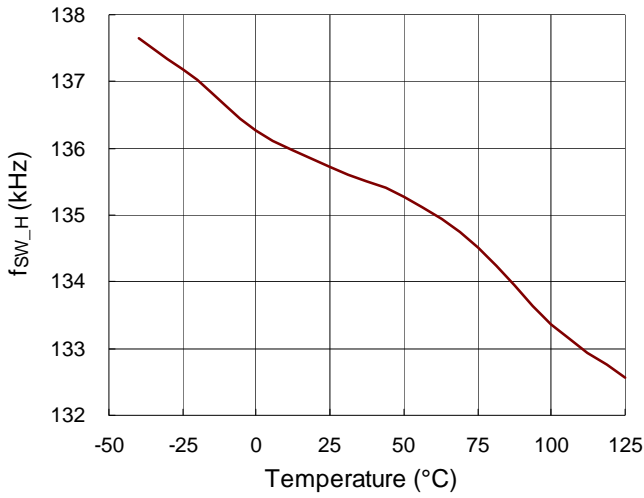

f_{sw_L} vs. Temperature

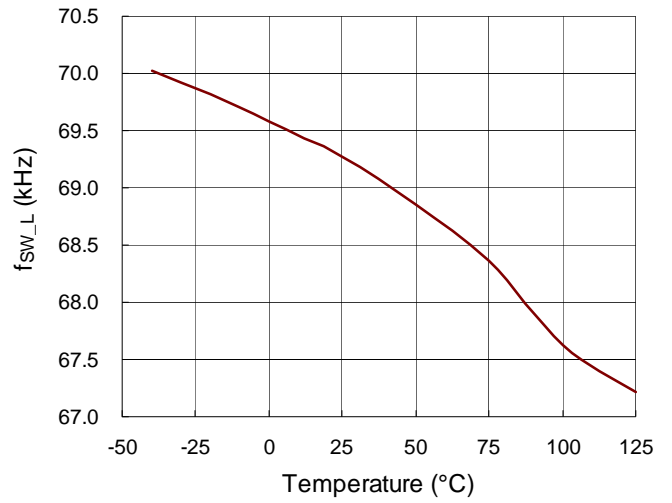

V_{CL} vs. Temperature

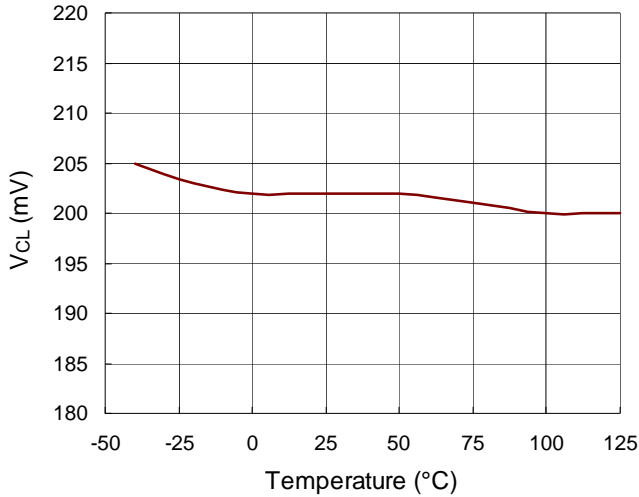

VCC-ISN Threshold vs. Temperature

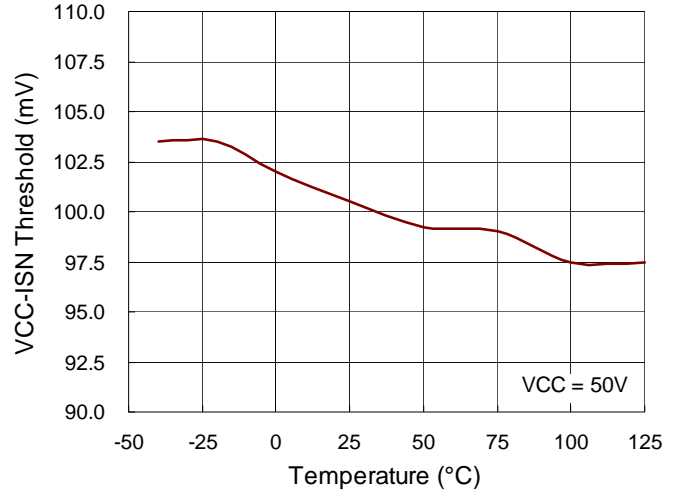

V_{DIM_EN} vs. Temperature

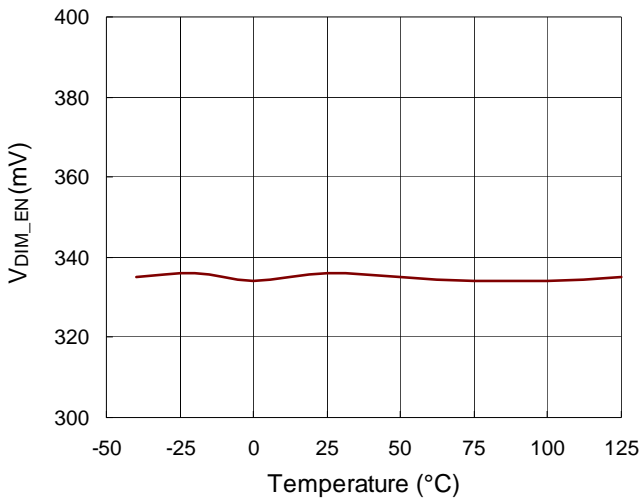

V_{DIM_DIS} vs. Temperature

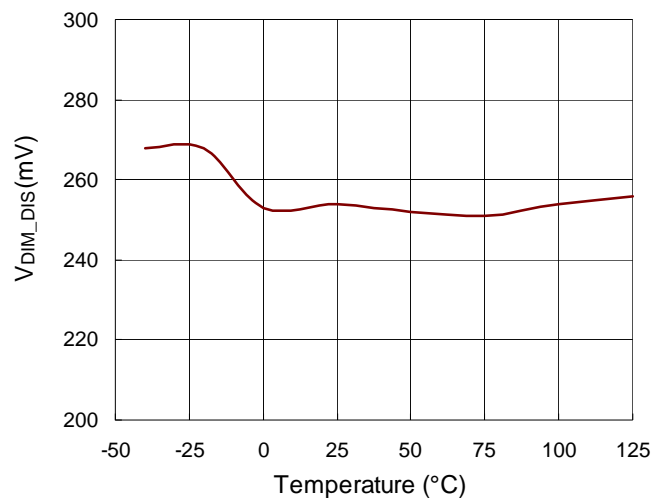

Application Information

The RT8406 is a fixed frequency current mode PWM controller designed to drive an external MOSFET for Buck LED applications. Two operating frequencies, 65kHz and 130kHz, can be selected for design flexibility. The control loop uses a current sense amplifier which senses the voltage between the VCC and ISN pins to achieve LED current regulation. The cycle-by-cycle peak current protection is built in the RT8406 to monitor the peak switch current and the current limit threshold can be set by the switch current sense resistor.

Frequency Selection

Two operating frequencies, 65kHz and 130kHz, can be set by the selection of the resistor connected to CS pin R4.

When R4 = 1kΩ, switching frequency = 130kHz.

When R4 = 2kΩ, switching frequency = 65kHz.

LED Current Setting

The Max. LED current can be set by the following equation :

$$I_{LED(MAX)} = \frac{100mV}{R1}$$

where R1 is the resistor between VCC and ISN pins.

Current Limit Setting

The RT8406 can limit the peak switch current by its internal over-current protection function. In normal operation, the power switch is turned off when the switch current hits the loop-set value. The over-current protection function can turn off the power switch once the CS pin level reaches the current limit threshold (210mV typ.). The resistor, R3, between the Source of the external NMOSFET and GND should be selected to provide adequate switch current without exceeding the current limit threshold. It is recommended to set I_{OCP} to be 130% to 150% of I_{L_PK}. The sense resistor value R3 can be calculated by the following equation :

$$R3 = \frac{\text{Current Limit Threshold Min. Value}}{I_{OCP}}$$

Inductor Selection

Choose an inductor that can handle the necessary peak current without saturating and ensure that the inductor has a low DCR (copper-wire resistance) to minimize I²R power losses. It is recommended to set the Max. inductor current ripple to be within 20% to 50%. Assume the converter operates in Continuous Conduction Mode (CCM) at Max. output current and the inductor current ripple = ±30%, the value of the required output inductor, L1, can be determined by the following equations :

$$L1 = \frac{V_{LED}}{2 \times I_{LED} \times 30\%} \times \left(1 - \frac{V_{LED}}{V_{IN}}\right) \times \frac{1}{f_{SW}}$$

Power MOSFET Selection

For the high input voltage and high frequency applications, the drain-source voltage rating V_{DS} and total gate charge Q_g for power N-MOS FET switch is the main consideration. The V_{DS} rating must be higher than input voltage. The lower Q_g at 10V is recommended to prevent RT8406 from over-heating.

Schottky Diode Selection

The Schottky diode, with low forward voltage drop and fast switching speed, is necessary for the RT8406 applications. In addition, power dissipation, reverse voltage rating and pulsating peak current are the important parameters for the Schottky diode selection. Choose a suitable Schottky diode whose reverse voltage rating is higher than the Max. input voltage. The diode's average current rating must exceed the average output current. The diode conducts current only when the power switch is turned off (typically less than 50% duty ratio).

Dimming Applications

The RT8406 provides two dimming control functions: analog and PWM dimming. Both dimming functions share the same pin and can dim the LED current from 100% to 0.5%, as shown in Figure 1. Two resistors R5 and R6 need to connect to DIM pin and the suggested resistances are R5 ≤ 51kΩ and R6 ≤ 510kΩ for f_{DIM} = 1kHz. When f_{DIM} = 2kHz, the values of R5 and R6 also need to adjust.

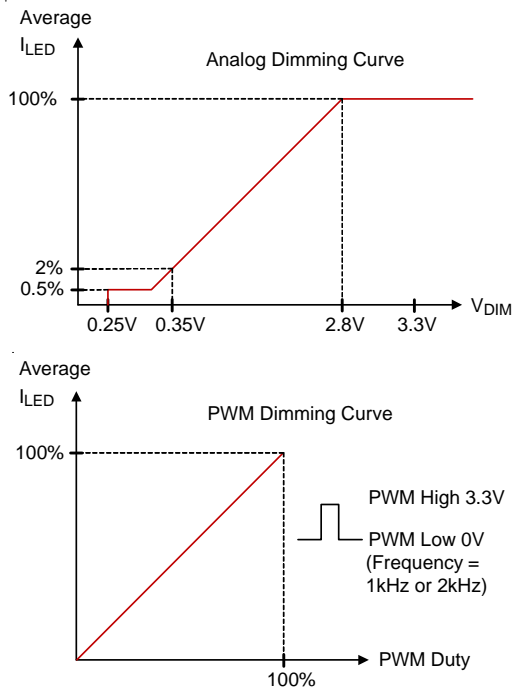

Figure 1. Dimming Curve

If there exists non-dimming requirement, a pull-high resistor of 1 to 2MΩ is needed to connect between DIM and VCC pins.

Thermal Considerations

The junction temperature should never exceed the absolute maximum junction temperature $T_{J(MAX)}$, listed under Absolute Maximum Ratings, to avoid permanent damage to the device. The maximum allowable power dissipation depends on the thermal resistance of the IC package, the PCB layout, the rate of surrounding airflow, and the difference between the junction and ambient temperatures. The maximum power dissipation can be calculated using the following formula :

$$P_{D(MAX)} = (T_{J(MAX)} - T_A) / \theta_{JA}$$

where $T_{J(MAX)}$ is the maximum junction temperature, T_A is the ambient temperature, and θ_{JA} is the junction-to-ambient thermal resistance.

For continuous operation, the maximum operating junction temperature indicated under Recommended Operating Conditions is 125°C. The junction-to-ambient thermal resistance, θ_{JA} , is highly package dependent. For a SOP-8, the thermal resistance, θ_{JA} , is 188°C/W on a standard JEDEC 51-7 high effective-thermal-conductivity four-layer

test board. The maximum power dissipation at $T_A = 25^\circ\text{C}$ can be calculated as below :

$$P_{D(MAX)} = (125^\circ\text{C} - 25^\circ\text{C}) / (188^\circ\text{C/W}) = 0.53\text{W for a SOP-8 package.}$$

The maximum power dissipation depends on the operating ambient temperature for the fixed $T_{J(MAX)}$ and the thermal resistance, θ_{JA} . The derating curves in Figure 2 allows the designer to see the effect of rising ambient temperature on the maximum power dissipation.

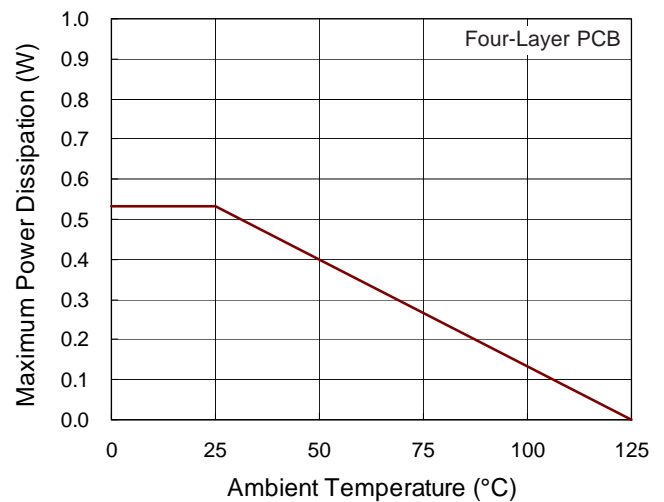

Figure 2. Derating Curve of Maximum Power Dissipation

Layout Considerations

For high frequency power switching converter circuits, the PCB layout is important to get good output regulation, high efficiency and stable performance. The following descriptions are the guidelines for better PCB layout.

- ▶ The power components C1, D1, L1, Q1, R1, R3 and C2 must be placed as close to each other as possible. The PCB trace between power components must be as short and wide as possible due to large current flow through these traces.
- ▶ Place Q1, L1 and D1 as close to each other as possible. Keep the common connected node (LX node) wide and short. Keep the LX node away from the DIM, VC, VCC, ISN and CS traces.
- ▶ The VCC pin is used to sense current so it must be directly connected to the node of R1 instead of VIN. And the ISN pin is connected to another node of R1. The current sensing signal traces for R1 must be kept away from any switching nodes.

- ▶ Place R4 and C3 as close to IC and near the CS pin as possible.
- ▶ Place C4 as close to VC pin as possible.
- ▶ Place R5, R6 and C6 as close to DIM pin as possible.
- ▶ The bypass capacitor C7 must be placed as close to VCC pin as possible.
- ▶ The bypass capacitor C5 must be placed as close to CREG pin as possible.
- ▶ It is good for switching noise reduction and output regulation to separate power ground trace and analog ground trace. Finally, connect them together at the input capacitor ground (C1). The area of these ground traces must be large enough especially for high current loop.

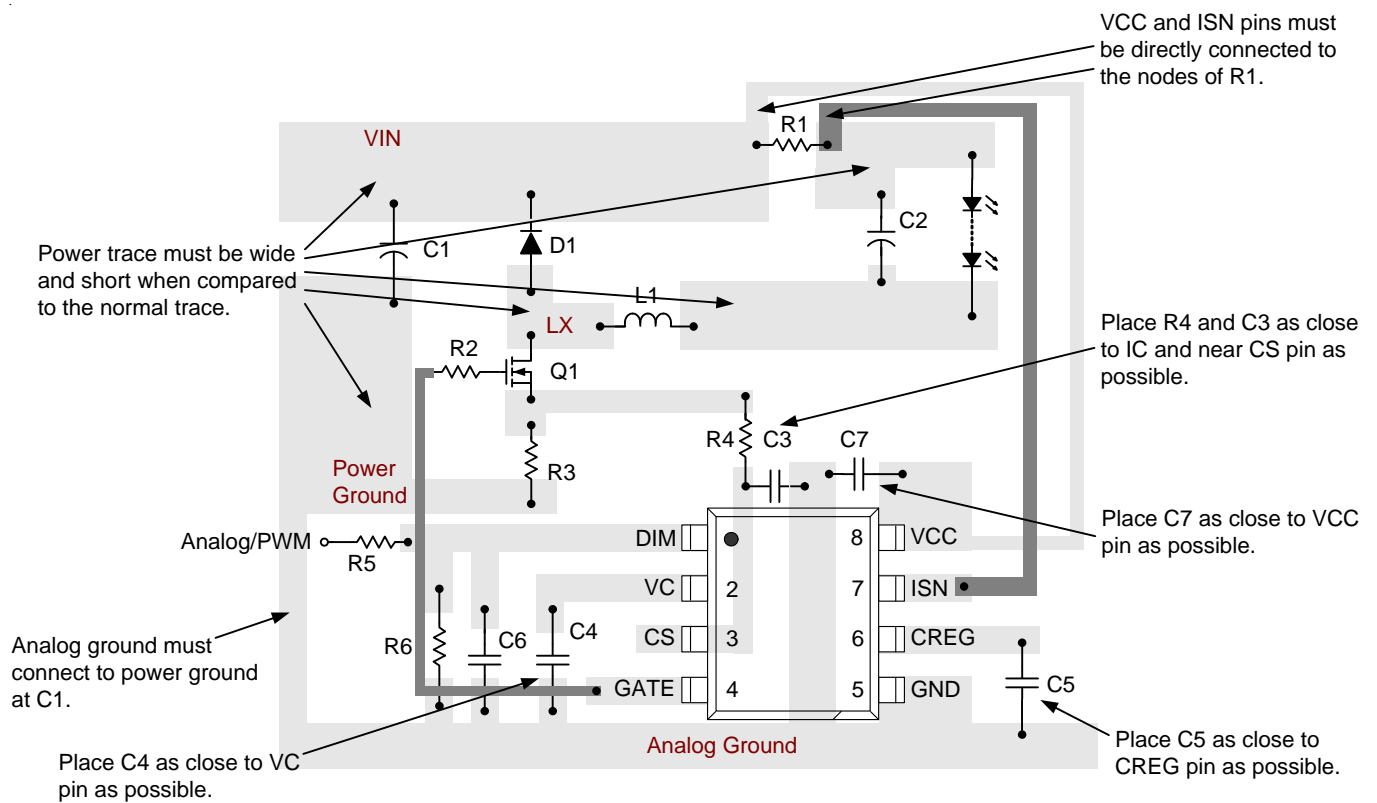
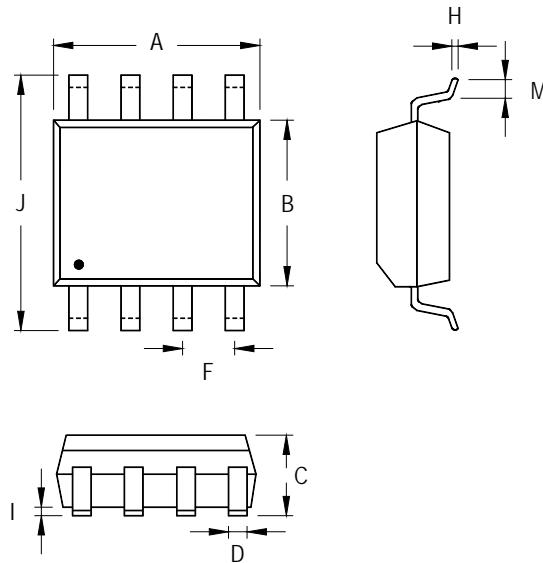

Figure 3. PCB Layout Guide

Outline Dimension



Symbol	Dimensions In Millimeters		Dimensions In Inches	
	Min	Max	Min	Max
A	4.801	5.004	0.189	0.197
B	3.810	3.988	0.150	0.157
C	1.346	1.753	0.053	0.069
D	0.330	0.508	0.013	0.020
F	1.194	1.346	0.047	0.053
H	0.170	0.254	0.007	0.010
I	0.050	0.254	0.002	0.010
J	5.791	6.200	0.228	0.244
M	0.400	1.270	0.016	0.050

8-Lead SOP Plastic Package

Richtek Technology Corporation

14F, No. 8, Tai Yuen 1st Street, Chupei City
 Hsinchu, Taiwan, R.O.C.
 Tel: (8863)5526789

Richtek products are sold by description only. Richtek reserves the right to change the circuitry and/or specifications without notice at any time. Customers should obtain the latest relevant information and data sheets before placing orders and should verify that such information is current and complete. Richtek cannot assume responsibility for use of any circuitry other than circuitry entirely embodied in a Richtek product. Information furnished by Richtek is believed to be accurate and reliable. However, no responsibility is assumed by Richtek or its subsidiaries for its use; nor for any infringements of patents or other rights of third parties which may result from its use. No license is granted by implication or otherwise under any patent or patent rights of Richtek or its subsidiaries.