

3A, 14V Step-Up DC/DC Converter

General Description

The RT8509 is a high performance switching boost converter that provides a regulated supply voltage for active matrix thin film transistor (TFT) liquid crystal displays (LCDs).

The RT8509 incorporates current mode, fixed-frequency, pulse width modulation (PWM) circuitry with a built in N-MOSFET to achieve high efficiency and fast transient response.

The RT8509 has a wide input voltage range from 2.8V to 14V. In addition, the output voltage can be adjusted up to 24V via an external resistive voltage divider. The maximum peak current is limited to 4.5A (typ.). Other features include programmable soft-start, over voltage protection, and over temperature protection.

The RT8509 is available in a WDFN-10L 3x3 package.

Ordering Information

RT8509 □□

- Package Type
QW : WDFN-10L 3x3 (W-Type)
- Lead Plating System
G : Green (Halogen Free and Pb Free)

Note :

Richtek products are :

- ▶ RoHS compliant and compatible with the current requirements of IPC/JEDEC J-STD-020.
- ▶ Suitable for use in SnPb or Pb-free soldering processes.

Features

- 90% Efficiency
- Adjustable Output Up to 24V
- 2.8V to 14V Input Supply Voltage
- Input Supply Under Voltage Lockout
- Fixed 1.2MHz Switching Frequency
- Programmable Soft-Start
- V_{OUT} Over Voltage Protection
- Over Temperature Protection
- Thin 10-Lead WDFN Package
- RoHS Compliant and Halogen Free

Applications

- GIP TFT LCD Panels

Pin Configurations

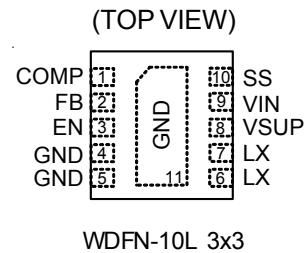

Marking Information

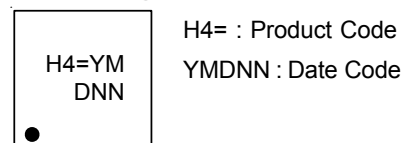

Typical Application Circuit

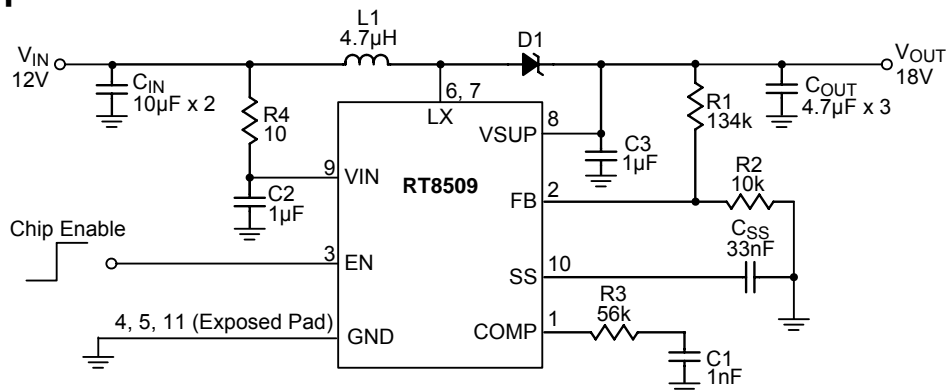

Functional Pin Description

Pin No.	Pin Name	Pin Function
1	COMP	Compensation Pin for Error Amplifier. Connect a series RC from COMP to ground.
2	FB	Feedback. The FB regulation voltage is 1.25V nominal. Connect an external resistive voltage divider between the step-up regulator's output (V _{OUT}) and GND, with the center tap connected to FB. Place the divider close to the IC and minimize the trace area to reduce noise coupling.
3	EN	Chip Enable. Drive EN low to turn off the Boost.
4, 5, 11 (Exposed Pad)	GND	Ground. The Exposed Pad must be soldered to a large PCB and connected to GND for maximum power dissipation.
6, 7	LX	Switch. LX is the drain of the internal MOSFET. Connect the inductor/rectifier diode junction to LX and minimize the trace area for lower EMI.
8	VSUP	Boost Converter Over Voltage Protection Input. Bypass VSUP with a minimum 1μF ceramic capacitor directly to GND.
9	VIN	Supply Input . Bypass VIN with a minimum 1μF ceramic capacitor directly to GND.
10	SS	Soft-Start Control. Connect a soft-start capacitor (C _{SS}) to this pin. The soft-start capacitor is charged with a constant current of 5μA. The soft-start capacitor is discharged to ground when EN is low.

Function Block Diagram

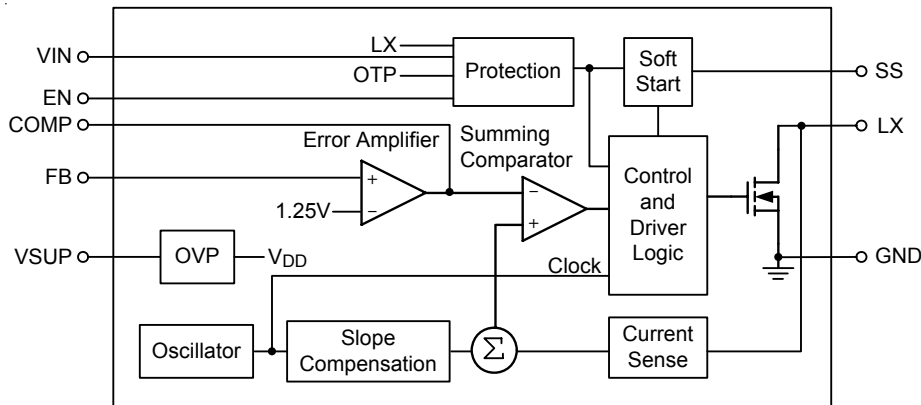

Absolute Maximum Ratings (Note 1)

- LX, VSUP to GND ----- -0.3V to 28V
- VIN, EN to GND ----- -0.3V to 16.5V
- Other Pins to GND ----- -0.3V to 6.5V
- Power Dissipation, P_D @ T_A = 25°C
 - WDFN-10L 3x3 ----- 1.429W
- Package Thermal Resistance (Note 2)
 - WDFN-10L 3x3, θ_{JA} ----- 70°C/W
 - WDFN-10L 3x3, θ_{JC} ----- 8.2°C/W
- Junction Temperature ----- 150°C
- Storage Temperature Range ----- -65°C to 150°C
- Lead Temperature (Soldering, 10sec.) ----- 260°C
- ESD Susceptibility (Note 3)
 - HBM (Human Body Model) ----- 2kV
 - MM (Machine Model) ----- 200V

Recommended Operating Conditions (Note 4)

- Ambient Temperature Range ----- -40°C to 85°C
- Junction Temperature Range ----- -40°C to 125°C

Electrical Characteristics

(V_{IN} = 3.3V, V_{OUT} = 10V, T_A = 25°C unless otherwise specified)

Parameter	Symbol	Test Conditions	Min	Typ	Max	Unit
Supply Current						
Input Voltage Range	V _{IN}		2.8	--	14	V
Output Voltage Range	V _{OUT}		--	--	24	V
Under Voltage Lockout Threshold	V _{UVLO}	V _{IN} Rising	--	2.5	3	V
UVLO Hysteresis	ΔV _{UVLO}		--	200	--	mV
VIN Quiescent Current	I _Q	V _{FB} = 1.3V, LX Not Switching	--	1	--	mA
		V _{FB} = 1V, LX Switching	--	5	--	
Thermal Shutdown Threshold	T _{SD}	Temperature Rising	--	155	--	°C
Thermal Shutdown Hysteresis	ΔT _{SD}		--	10	--	°C
VSUP Over Voltage Threshold		VSUP Rising	--	26	--	V
Oscillator						
Oscillator Frequency	f _{OSC}		1000	1200	1500	kHz
Maximum Duty Cycle	D _{MAX}		--	90	--	%
Error Amplifier						
FB Regulation Voltage	V _{REF}		--	1.25	--	V
FB Input Bias Current	I _{FB}		--	--	100	nA
FB Line Regulation			--	0.05	0.2	%/V

Parameter	Symbol	Test Conditions	Min	Typ	Max	Unit
Transconductance	gm	$\Delta I = \pm 2.5\mu A$ at $V_{COMP} = 1V$	--	100	--	$\mu A/V$
Voltage Gain	A_V	FB to COMP	--	700	--	V/V
N-MOSFET						
Current Limit	I_{LIM}		3	3.5	--	A
On-Resistance	$R_{DS(ON)}$		--	100	250	$m\Omega$
Leakage Current	I_{LEAK}	$V_{LX} = 24V$	--	30	45	μA
Current Sense Transresistance	R_{CS}		--	0.25	--	V/A
Soft-Start						
Charge Current			--	5	--	μA
Control Inputs						
EN Input Voltage	Logic-High	V_{IH}	1.5	--	--	V
	Logic-Low	V_{IL}	--	--	0.5	

Note 1. Stresses beyond those listed "Absolute Maximum Ratings" may cause permanent damage to the device. These are stress ratings only, and functional operation of the device at these or any other conditions beyond those indicated in the operational sections of the specifications is not implied. Exposure to absolute maximum rating conditions may affect device reliability.

Note 2. θ_{JA} is measured at $T_A = 25^\circ C$ on a high effective thermal conductivity four-layer test board per JEDEC 51-7. θ_{JC} is measured at the exposed pad of the package.

Note 3. Devices are ESD sensitive. Handling precaution is recommended.

Note 4. The device is not guaranteed to function outside its operating conditions.

Typical Operating Characteristics

Boost Efficiency vs. Load Current

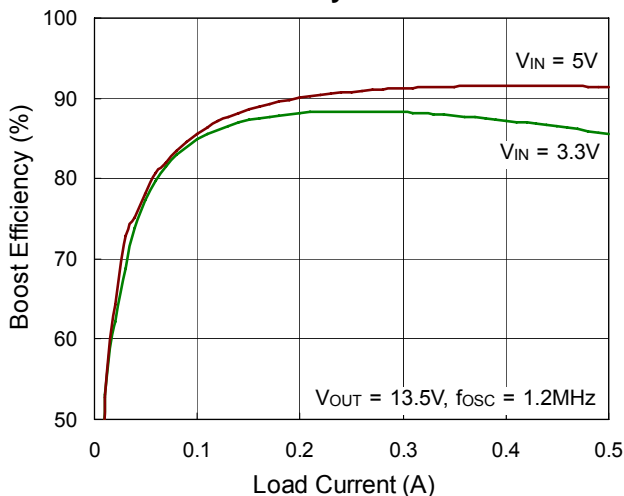

Boost Efficiency vs. Load Current

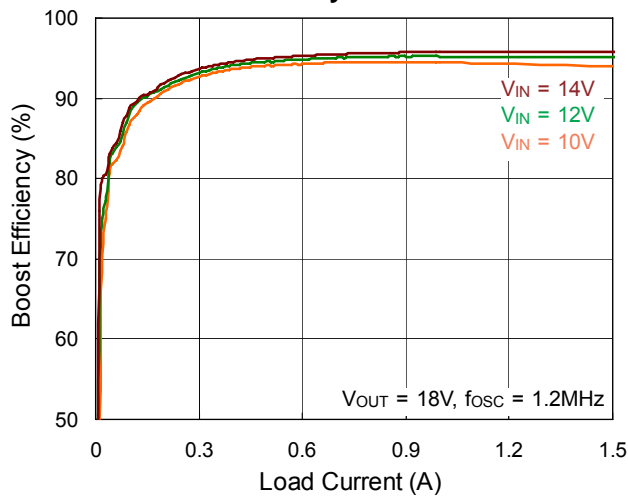

Boost Reference Voltage vs. Temperature

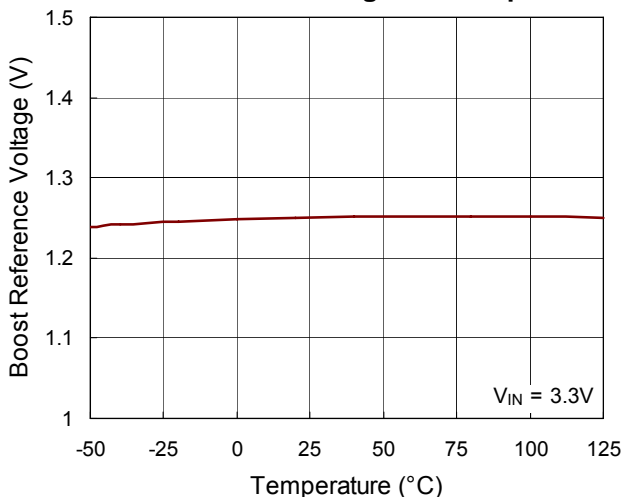

Boost Frequency vs. Temperature

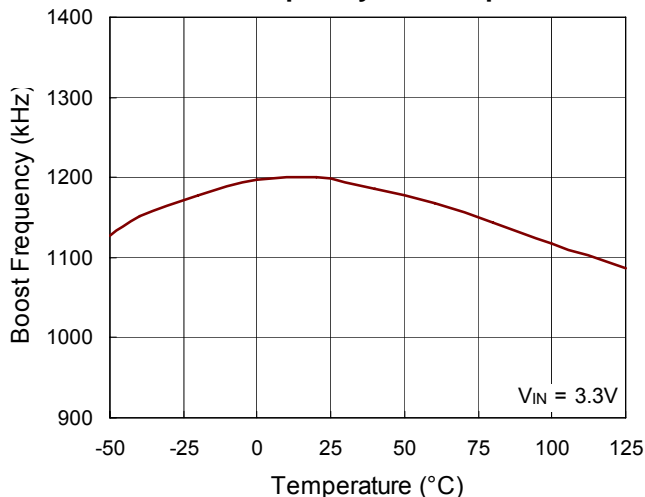

Boost Reference Voltage vs. Input Voltage

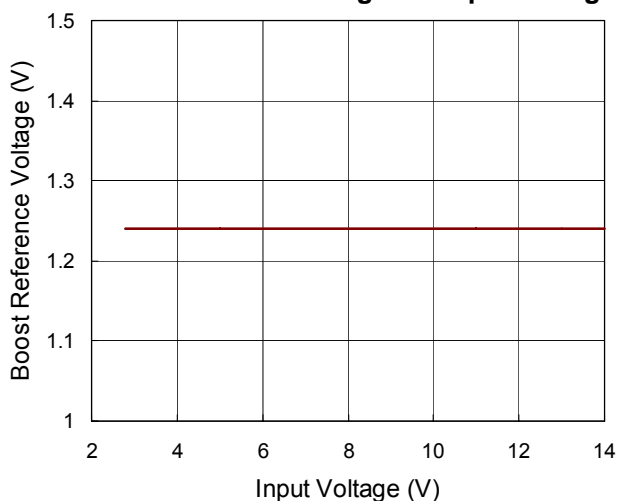

Boost Current Limit vs. Input Voltage

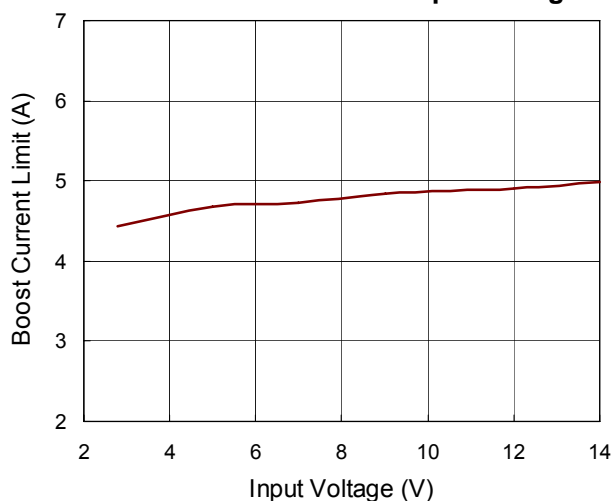

Application Information

The RT8509 is a high performance step-up DC/DC converter that provides a regulated supply voltage for panel source driver ICs. The RT8509 incorporates current mode, fixed frequency, Pulse Width Modulation (PWM) circuitry with a built in N-MOSFET to achieve high efficiency and fast transient response. The following content contains detailed description and information for component selection.

Boost Regulator

The RT8509 is a current mode boost converter integrated with a 24V/3.5A power switch, covering a wide V_{IN} range from 2.8V to 14V. It performs fast transient responses to generate source driver supplies for TFT LCD display. The high operation frequency allows use of smaller components to minimize the thickness of the LCD panel. The output voltage can be adjusted by setting the resistive voltage-divider sensing at the FB pin. The error amplifier varies the COMP voltage by sensing the FB pin to regulate the output voltage. For better stability, the slope compensation signal summed with the current sense signal will be compared with the COMP voltage to determine the current trip point and duty cycle.

Soft-Start

The RT8509 provides soft-start function to minimize the inrush current. When powered on, an internal constant current charges an external capacitor. The rising voltage rate on the COMP pin is limited from $V_{SS} = 0V$ to 1.24V and the inductor peak current will also be limited at the same time. When powered off, the external capacitor will be discharged until the next soft-start time.

The soft-start function is implemented by the external capacitor with a 5 μ A constant current charging to the soft-start capacitor. Therefore, the capacitor should be large enough for output voltage regulation. A typical value for soft-start capacitor is 33nF. The available soft-start capacitor range is from 10nF to 100nF.

If $C_{SS} < 220pF$, the internal soft-start function will be turned on and period time is approximately 1ms.

Output Voltage Setting

The regulated output voltage is shown as the following equation :

$$V_{OUT} = V_{REF} \times \left(1 + \frac{R1}{R2} \right), \text{ where } V_{REF} = 1.25V \text{ (typ.)}$$

The recommended value for R2 should be at least 10k Ω without some sacrificing. Place the resistive voltage divider as close as possible to the chip to reduce noise sensitivity.

Loop Compensation

The voltage feedback loop can be compensated with an external compensation network consisting of R3. Choose R3 to set high frequency integrator gain for fast transient response and C1 to set the integrator zero to maintain loop stability. For typical application, $V_{IN} = 5V$, $V_{OUT} = 13.6V$, $C_{OUT} = 4.7\mu F \times 3$, $L1 = 4.7\mu H$, while the recommended value for compensation is as follows : R3 = 56k Ω , C1 = 1nF.

Over Current Protection

The RT8509 boost converter has over current protection to limit the peak inductor current. It prevents large current from damaging the inductor and diode. During the On-time, once the inductor current exceeds the current limit, the internal LX switch turns off immediately and shortens the duty cycle. Therefore, the output voltage drops if the over current condition occurs. The current limit is also affected by the input voltage, duty cycle, and inductor value.

Over Temperature Protection

The RT8509 boost converter has thermal protection function to prevent the chip from overheating. When the junction temperature exceeds 155 $^{\circ}C$, the function shuts down the device. Once the device cools down by approximately 10 $^{\circ}C$, it will automatically restart to normal operation. To guarantee continuous operation, do not operate over the maximum junction temperature rating of 125 $^{\circ}C$.

Inductor Selection

The inductance depends on the maximum input current. As a general rule, the inductor ripple current range is 20% to 40% of the maximum input current. If 40% is selected

as an example, the inductor ripple current can be calculated according to the following equations :

$$I_{IN(MAX)} = \frac{V_{OUT} \times I_{OUT(MAX)}}{\eta \times V_{IN}}$$

$$I_{RIPPLE} = 0.4 \times I_{IN(MAX)}$$

where η is the efficiency of the converter, $I_{IN(MAX)}$ is the maximum input current, and I_{RIPPLE} is the inductor ripple current. The input peak current can then be obtained by adding the maximum input current with half of the inductor ripple current as shown in the following equation :

$$I_{PEAK} = 1.2 \times I_{IN(MAX)}$$

Note that the saturated current of the inductor must be greater than I_{PEAK} . The inductance can eventually be determined according to the following equation :

$$L = \frac{\eta \times (V_{IN})^2 \times (V_{OUT} - V_{IN})}{0.4 \times (V_{OUT})^2 \times I_{OUT(MAX)} \times f_{OSC}}$$

where f_{OSC} is the switching frequency. For better system performance, a shielded inductor is preferred to avoid EMI problems.

Diode Selection

Schottky diodes are chosen for their low forward voltage drop and fast switching speed. When selecting a Schottky diode, important parameters such as power dissipation, reverse voltage rating, and pulsating peak current should all be taken into consideration. A suitable Schottky diode's reverse voltage rating must be greater than the maximum output voltage and its average current rating must exceed the average output current. Last of all, the chosen diode should have a sufficiently low leakage current level, since it will increase with temperature.

Output Capacitor Selection

The output ripple voltage is an important index for estimating chip performance. This portion consists of two parts. One is the product of the inductor current with the ESR of the output capacitor, while the other part is formed by the charging and discharging process of the output capacitor. As shown in Figure 1, ΔV_{OUT1} can be evaluated based on the ideal energy equalization. According to the definition of Q, the Q value can be calculated as the following equation :

$$Q = \frac{1}{2} \times \left[\left(I_{IN} + \frac{1}{2} \Delta I_L - I_{OUT} \right) + \left(I_{IN} - \frac{1}{2} \Delta I_L - I_{OUT} \right) \right] \times \frac{V_{IN}}{V_{OUT}} \times \frac{1}{f_{OSC}} = C_{OUT} \times \Delta V_{OUT1}$$

where f_{OSC} is the switching frequency, and ΔI_L is the inductor ripple current. Bring C_{OUT} to the left side to estimate the value of ΔV_{OUT1} according to the following equation :

$$\Delta V_{OUT1} = \frac{D \times I_{OUT}}{\eta \times C_{OUT} \times f_{OSC}}$$

where D is the duty cycle and η is the boost converter efficiency. Finally, taking ESR into account, the overall output ripple voltage can be determined by the following equation :

$$\Delta V_{OUT} = I_{IN} \times ESR + \frac{D \times I_{OUT}}{\eta \times C_{OUT} \times f_{OSC}}$$

The output capacitor, C_{OUT} , should be selected accordingly.

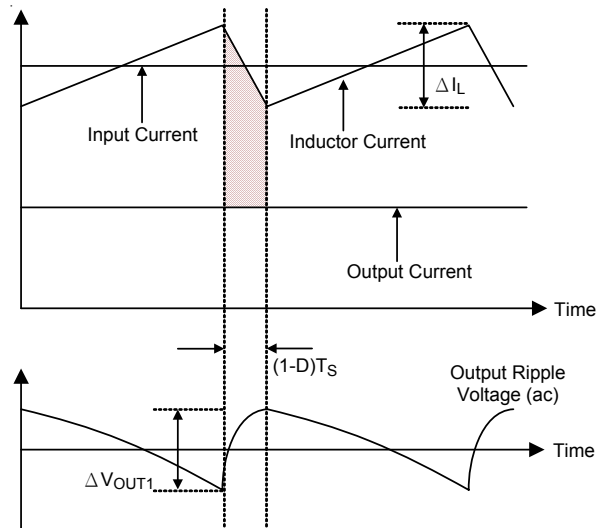

Figure 1. The Output Ripple Voltage without the Contribution of ESR

Input Capacitor Selection

Low ESR ceramic capacitors are recommended for input capacitor applications. Low ESR will effectively reduce the input voltage ripple caused by switching operation. A 10 μ F capacitor is sufficient for most applications. Nevertheless, this value can be decreased for lower output current requirement. Another consideration is the voltage rating of the input capacitor which must be greater than the maximum input voltage.

Thermal Considerations

For continuous operation, do not exceed absolute maximum junction temperature. The maximum power dissipation depends on the thermal resistance of the IC package, PCB layout, rate of surrounding airflow, and difference between junction and ambient temperature. The maximum power dissipation can be calculated by the following formula :

$$P_{D(MAX)} = (T_{J(MAX)} - T_A) / \theta_{JA}$$

where $T_{J(MAX)}$ is the maximum junction temperature, T_A is the ambient temperature, and θ_{JA} is the junction to ambient thermal resistance.

For recommended operating condition specifications, the maximum junction temperature is 125°C. The junction to ambient thermal resistance, θ_{JA} , is layout dependent. For WDFN-10L 3x3 packages, the thermal resistance, θ_{JA} , is 70°C/W on a standard JEDEC 51-7 four-layer thermal test board. The maximum power dissipation at $T_A = 25^\circ\text{C}$ can be calculated by the following formula :

$$P_{D(MAX)} = (125^\circ\text{C} - 25^\circ\text{C}) / (70^\circ\text{C/W}) = 1.429\text{W for WDFN-10L 3x3 package}$$

The maximum power dissipation depends on the operating ambient temperature for fixed $T_{J(MAX)}$ and thermal resistance, θ_{JA} . The derating curve in Figure 2 allows the designer to see the effect of rising ambient temperature on the maximum power dissipation.

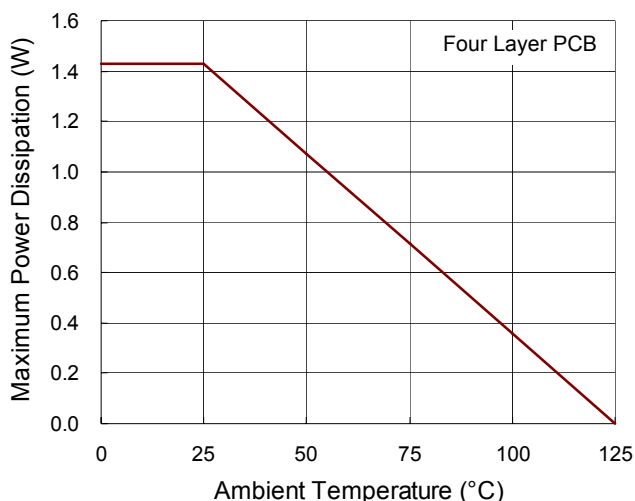

Figure 2. Derating Curve of Maximum Power Dissipation

Layout Considerations

For high frequency switching power supplies, the PCB layout is important to get good regulation, high efficiency and stability. The following descriptions are the guidelines for better PCB layout.

- ▶ For good regulation, place the power components as close as possible. The traces should be wide and short enough especially for the high current output loop.
- ▶ The feedback voltage divider resistors must be near the feedback pin. The divider center trace must be shorter and the trace must be kept away from any switching nodes.
- ▶ The compensation circuit should be kept away from the power loops and be shielded with a ground trace to prevent any noise coupling.
- ▶ Minimize the size of the LX node and keep it wide and shorter. Keep the LX node away from the FB.
- ▶ The exposed pad of the chip should be connected to a strong ground plane for maximum thermal consideration.

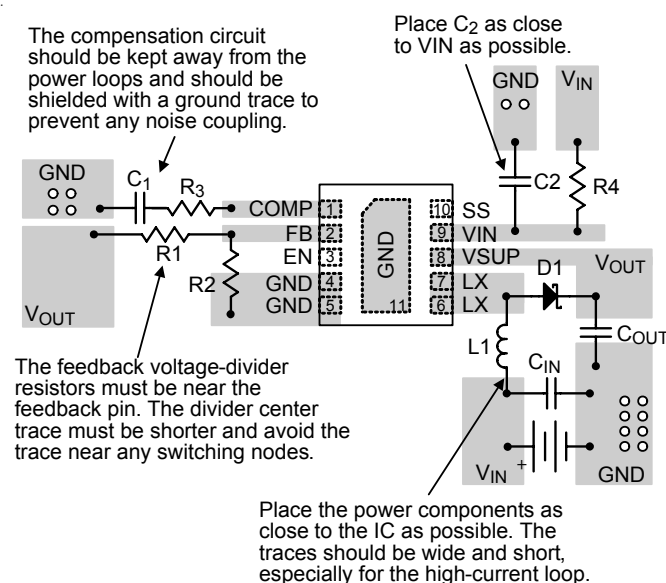
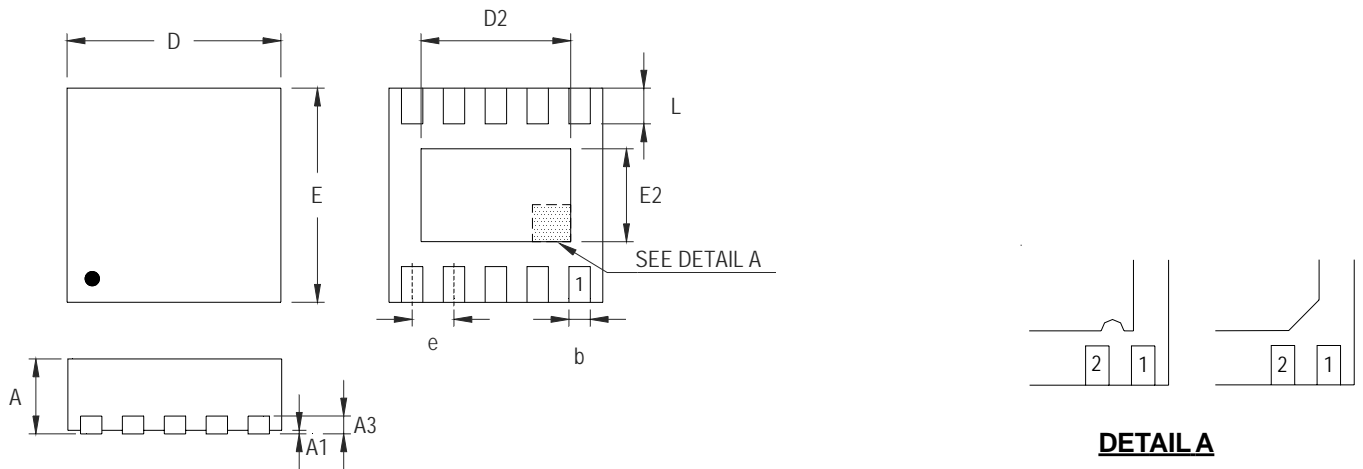

Figure 3. PCB Layout Guide

Outline Dimension



DETAIL A

Pin #1 ID and Tie Bar Mark Options

Note : The configuration of the Pin #1 identifier is optional, but must be located within the zone indicated.

Symbol	Dimensions In Millimeters		Dimensions In Inches	
	Min	Max	Min	Max
A	0.700	0.800	0.028	0.031
A1	0.000	0.050	0.000	0.002
A3	0.175	0.250	0.007	0.010
b	0.180	0.300	0.007	0.012
D	2.950	3.050	0.116	0.120
D2	2.300	2.650	0.091	0.104
E	2.950	3.050	0.116	0.120
E2	1.500	1.750	0.059	0.069
e	0.500		0.020	
L	0.350	0.450	0.014	0.018

W-Type 10L DFN 3x3 Package

Richtek Technology Corporation

5F, No. 20, Taiyuen Street, Chupei City
 Hsinchu, Taiwan, R.O.C.
 Tel: (8863)5526789

Richtek products are sold by description only. Richtek reserves the right to change the circuitry and/or specifications without notice at any time. Customers should obtain the latest relevant information and data sheets before placing orders and should verify that such information is current and complete. Richtek cannot assume responsibility for use of any circuitry other than circuitry entirely embodied in a Richtek product. Information furnished by Richtek is believed to be accurate and reliable. However, no responsibility is assumed by Richtek or its subsidiaries for its use; nor for any infringements of patents or other rights of third parties which may result from its use. No license is granted by implication or otherwise under any patent or patent rights of Richtek or its subsidiaries.