

High Voltage 8-CH LED Driver

General Description

The RT8572 is an 8-CH LED driver capable of delivering 60mA for each channel. The RT8572 is a current mode boost converter with an adjustable switching frequency via the RT pin from 100kHz to 1MHz and a wide VIN range from 9V to 28V.

The PWM output voltage loop selects and regulates the LED pin with the highest voltage string to 0.6V, hence allowing voltage mismatches between LED strings. The RT8572 automatically detects and disconnects any unconnected and/or broken strings during operation from PWM loop to prevent V_{OUT} from over voltage. The 1.5% matched LED currents on all channels are simply programmed with a resistor. A very high contrast ratio true digital PWM dimming can be achieved by driving the PWM pin with a PWM signal.

When an abnormal situation (open/short/thermal) occurs, a status signal will be sent to the system to shut down the IC.

The RT8572 is available in an SOP-24 package.

Ordering Information

RT8572 □ □

- Package Type
S : SOP-24
- Lead Plating System
G : Green (Halogen Free and Pb Free)

Note :

Richtek products are :

- ▶ RoHS compliant and compatible with the current requirements of IPC/JEDEC J-STD-020.
- ▶ Suitable for use in SnPb or Pb-free soldering processes.

Marking Information

RT8572 GSYMDNN ●	RT8572GS : Product Number YMDNN : Date Code
------------------------	--

Features

- Wide Input Supply Voltage Range : 9V to 28V
- Adjustable Boost Controller Switching Frequency from 100kHz to 1MHz
- Programmable Channel Current
- Channel Current Matching : ±1.5%
- External Dimming Control
- Boost MOSFET Over Current Protection
- Automatic LED Open/Short Protection to Avoid Output Over Voltage
- VCC Under Voltage Lockout
- Adjustable Over Voltage Protection
- Under Voltage Protection
- Thermal Shutdown Protection
- Abnormal Status Indicator for Open/Short/Thermal Condition
- RoHS Compliant and Halogen Free

Applications

- LCD TV, Monitor Display Backlight
- LEDDriver Application
- General Purpose Constant Current Source

Pin Configurations

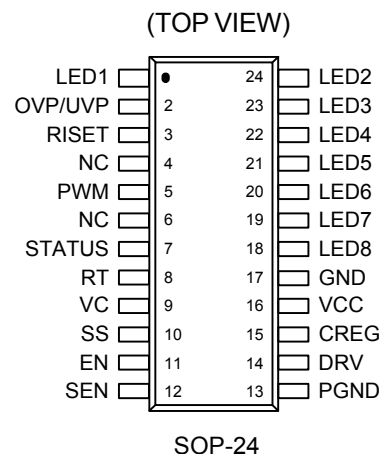

Typical Application Circuit

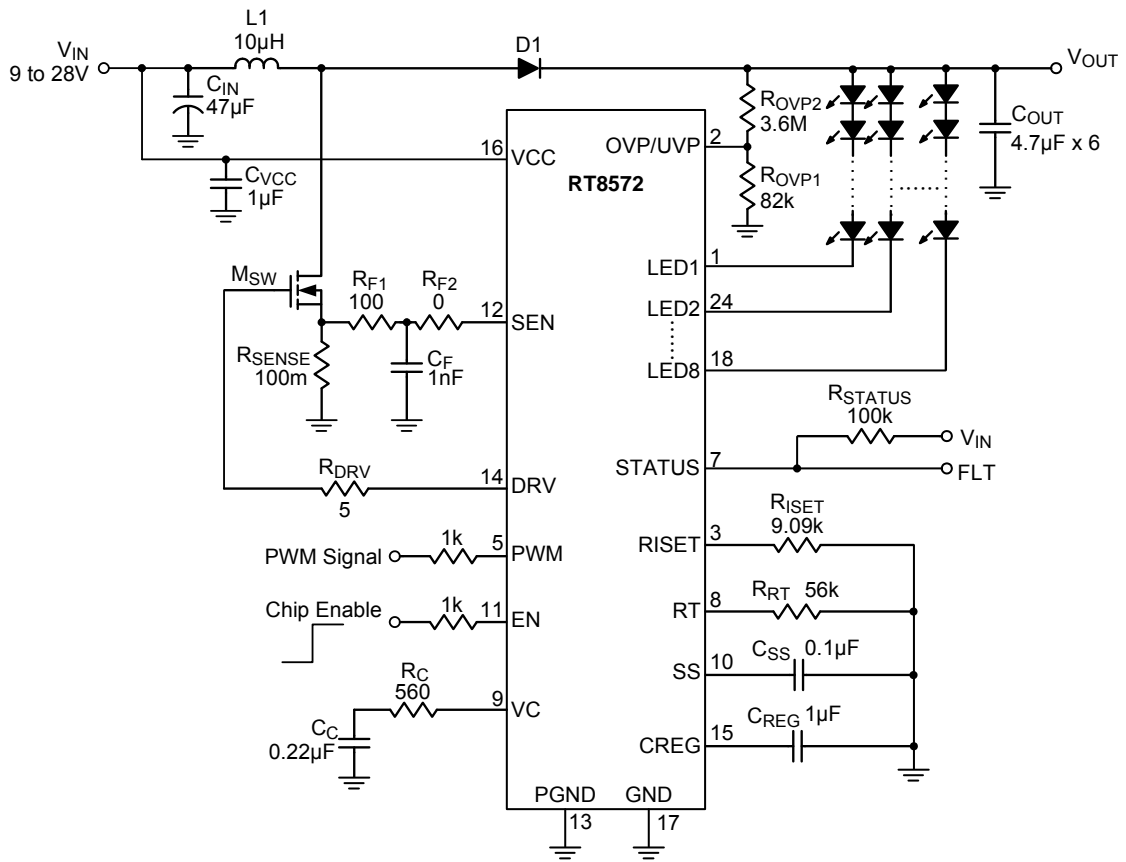

Figure 1. General Application

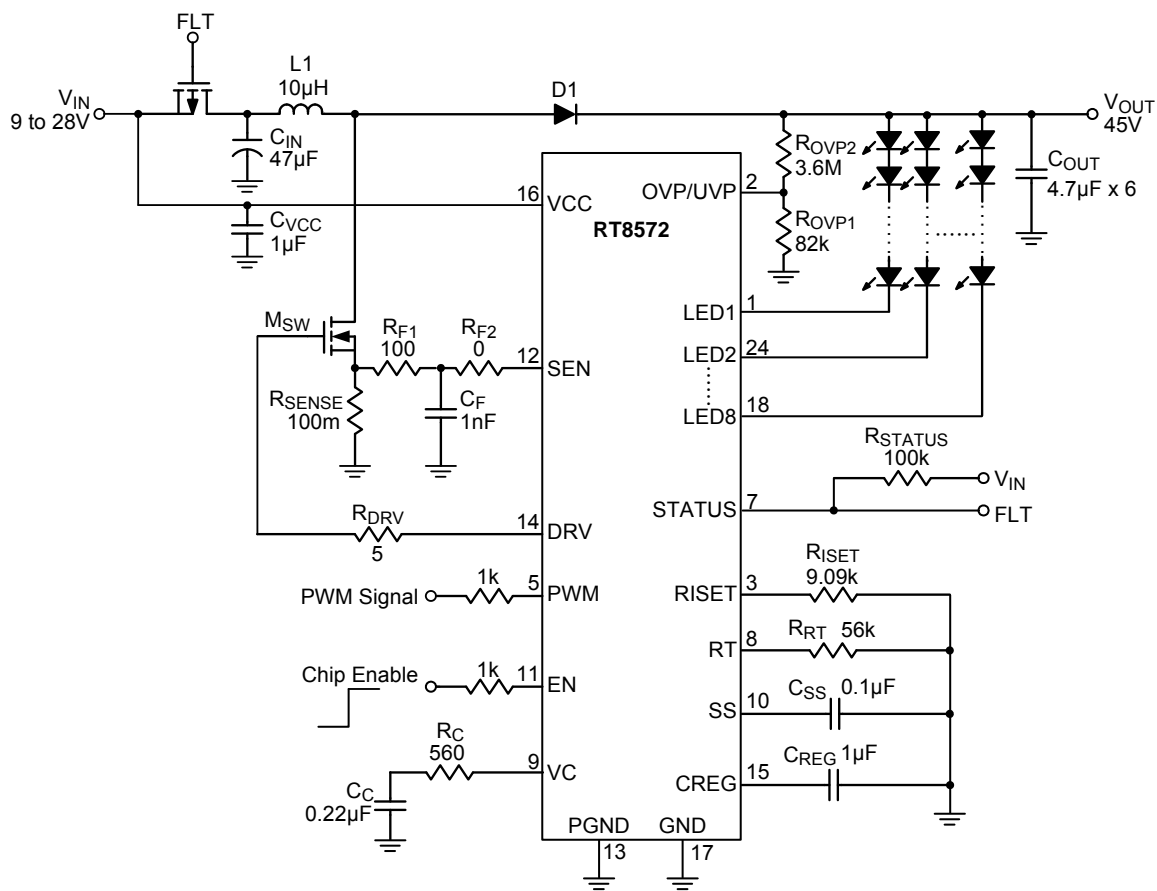
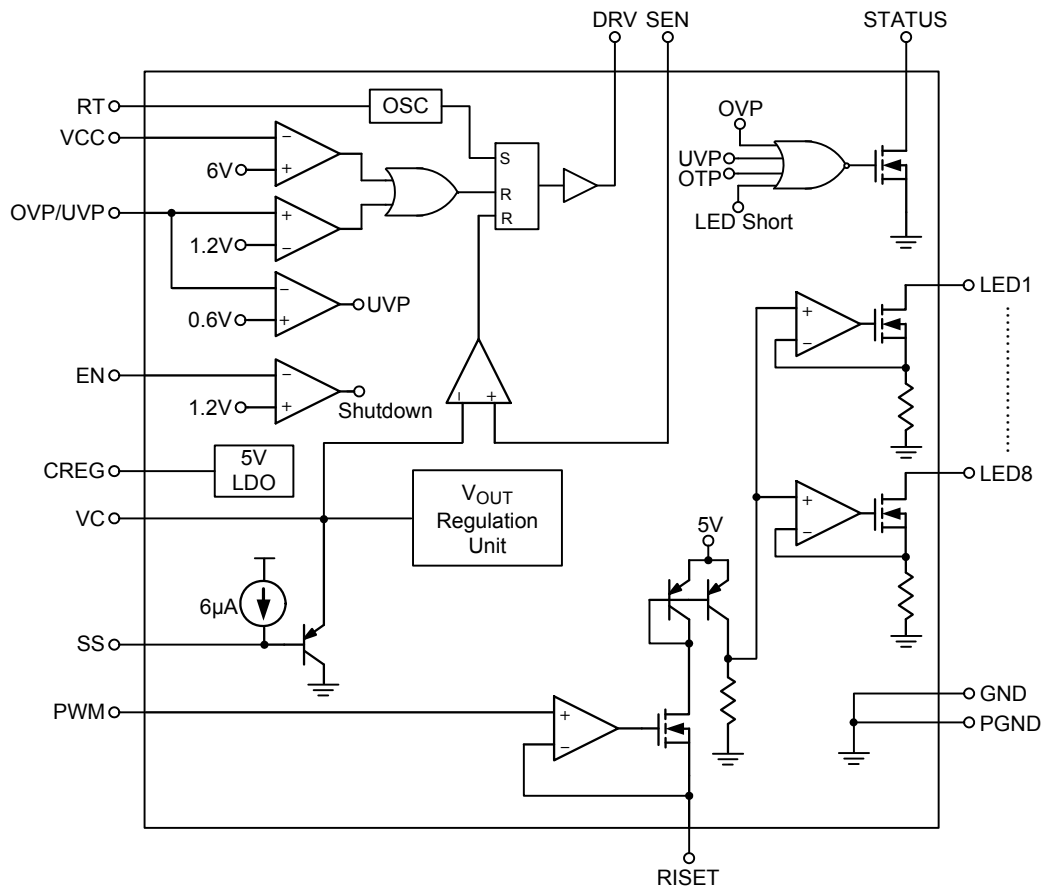

Figure 2. External P-MOSFET Isolation Application

Functional Pin Description

Pin No.	Pin Name	Pin Function
1	LED1	Channel 1 LED Current Sink. Leave this pin unconnected if it is not used.
2	OVP/UVP	Over Voltage and Under Voltage Protection. PWM boost converter turns off when V_{OVP} or V_{UVP} goes higher than 1.2V or lower than 0.6V, respectively.
3	RISET	LED Current Set Pin. A resistor or a current from DAC on this pin programs the full LED current.
4, 6	NC	No Internal Connection.
5	PWM	Dimming Control Input.
7	STATUS	Boost Converter Operation Status Output.
8	RT	Switching Frequency Set. Connect a resistor between RT and GND to set the boost converter switching frequency.
9	VC	PWM Boost Converter Loop Compensation Node.
10	SS	Soft-Start Pin. Place a capacitor of at least 10nF from this pin to GND to set the soft-start time period.
11	EN	Chip Enable. When EN is pulled low, chip will be in shutdown mode.
12	SEN	Current Sense Input. During normal operation, this pin senses the voltage across the external inductor current sensing resistor for peak current mode control and also to limit the inductor current during every switching cycle.
13	PGND	Boost Converter Power Ground.
14	DRV	Boost Converter Power Switch Gate Output. This pin drives the external power N-MOSFET device.
15	CREG	1 μ F capacitor should be placed on this pin to stabilize the 5V output of the internal regulator. This regulator is for chip internal use only.
16	VCC	Power Supply of the Chip. For good bypass, a low ESR capacitor is required.
17	GND	Ground Pin.
18 to 24	LED8 to LED2	Channel 8 to Channel 2 LED Current Sink. Leave the pins unconnected if not in use.

Function Block Diagram



Absolute Maximum Ratings (Note 1)

- Supply Voltage, V_{CC}, STATUS ----- 33V
- LED1 to LED8 ----- 50V
- PWM, EN, DRV, SEN, SS, VC, RT, CREG, OVP/UVP, Riset ----- 5.5V
- Power Dissipation, P_D @ T_A = 25°C
 - SOP-24 ----- 1.111W
- Package Thermal Resistance (Note 2)
 - SOP-24, θ_{JA} ----- 90°C/W
- Junction Temperature ----- 150°C
- Lead Temperature (Soldering, 10 sec.) ----- 260°C
- Storage Temperature Range ----- -65°C to 150°C
- ESD Susceptibility (Note 3)
 - HBM (Human Body Mode) ----- 2kV
 - MM (Machine Mode) ----- 200V

Recommended Operating Conditions (Note 4)

- Supply Voltage, V_{CC} ----- 9V to 28V
- LED1 to LED8 ----- 45V
- Junction Temperature Range ----- -40°C to 125°C
- Ambient Temperature Range ----- -40°C to 85°C

Electrical Characteristics

(V_{CC} = 12V, T_A = 25°C, unless otherwise specified)

Parameter	Symbol	Test Conditions	Min	Typ	Max	Unit
Supply Voltage						
Supply Current	I _{VCC}	Switching Off	--	5	--	mA
Shutdown Current	I _{SHDN}	V _{EN} < 0.7V	--	--	10	μA
VDD LDO Output	V _{CREG}		--	5	--	V
VDD LDO Capability	I _{CREG}		30	--	--	mA
VCC UVLO Threshold	V _{UVLO}	VCC Rising	--	--	8	V
		Hysteresis	--	1.4	--	
EN Input Threshold Voltage	Logic-High	V _{ENH}	1.5	--	--	V
	Logic-Low	V _{ENL}	--	--	0.8	
LED Current Programming						
LED Current		R _{RISET} = 9.09kΩ, V _{PWM} > 1.2V	57	60	63	mA
LED Current Matching		I _{LED} = 60mA $\frac{I_{(MAX)} - I_{(MIN)}}{2 \times I_{(Avg)}} \times 100\%$	--	±1.5	±3	%
LED1 to LED8 Regulation Voltage		I _{LED} = 60mA	--	0.6	--	V
V _{LED} Threshold		No Connection	--	0.1	--	V
RISET Pin Voltage			--	1.2	--	V

To be continued

Parameter	Symbol	Test Conditions	Min	Typ	Max	Unit
Dimming						
PWM Input Threshold Voltage	Logic-High	V _{PWMH}	1.2	--	--	V
	Logic-Low	V _{PWML}	--	--	0.4	
PWM Boost Controller						
Switching Frequency	f _{SW}	R _{RT} = 24kΩ	--	1	--	MHz
		R _{RT} = Open	--	100	--	kHz
Minimum On Time	t _{ON}		--	100	--	ns
Maximum Duty Cycle	D _{max}		80	--	--	%
SEN Current Sense Limit		Input Current Limit	--	0.5	--	V
Gate Driver Source			--	2.5	--	A
Gate Driver Sink			--	3	--	A
OVP, UVP, OTP and Soft-Start						
OVP Threshold	V _{OVP}		1.1	1.2	1.3	V
UVP Threshold	V _{UVP}		0.57	0.6	0.63	V
SCP Threshold	V _{SCP}	LED1 to LED8	--	4.3	--	V
Soft-Start Current	I _{SS}	V _{SS} < 2.5V	--	6	--	μA
Thermal Shutdown Temperature	T _{SD}	Lockout Temperature Point	--	150	--	°C
Thermal Shutdown Hysteresis	ΔT _{SD}	Resume Temperature Point	--	20	--	°C
STATUS Low Voltage	V _{STATUS}	Open Drain at 10mA	--	--	0.5	V

Note 1. Stresses listed as the above “Absolute Maximum Ratings” may cause permanent damage to the device. These are for stress ratings. Functional operation of the device at these or any other conditions beyond those indicated in the operational sections of the specifications is not implied. Exposure to absolute maximum rating conditions for extended periods may remain possibility to affect device reliability.

Note 2. θ_{JA} is measured in natural convection at T_A = 25°C on a low-effective thermal conductivity single-layer test board of JEDEC 51-3 thermal measurement standard.

Note 3. Devices are ESD sensitive. Handling precaution is recommended.

Note 4. The device is not guaranteed to function outside its operating conditions.

Typical Operating Characteristics

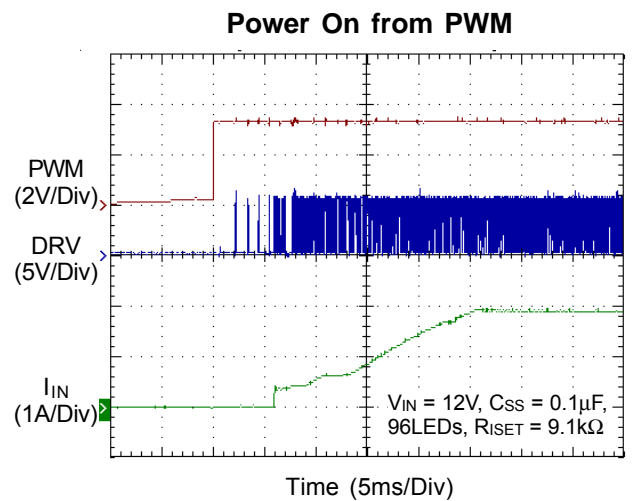
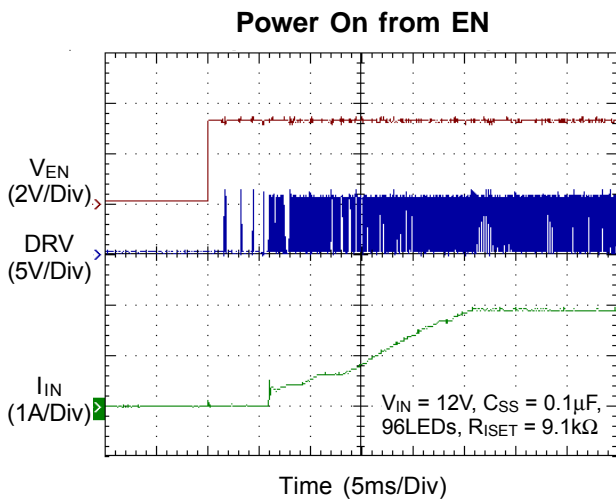
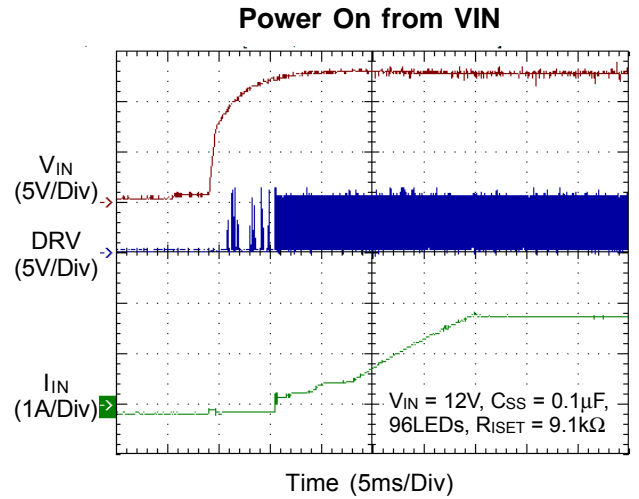
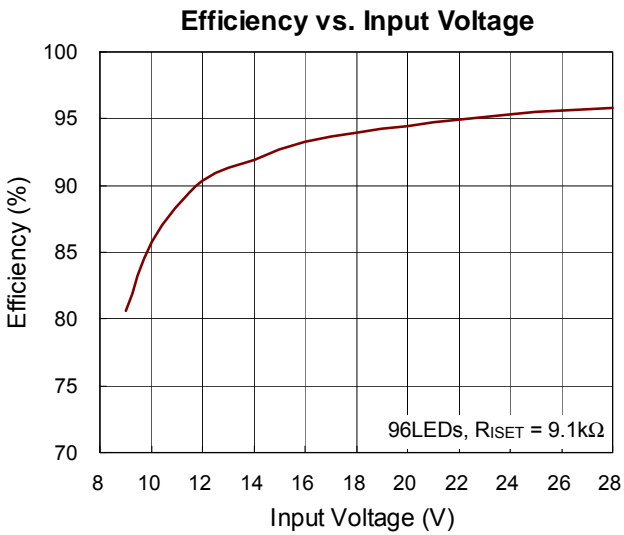
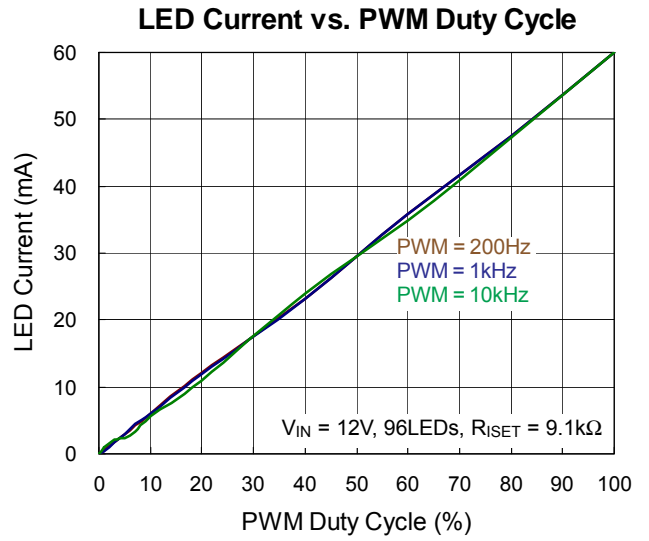
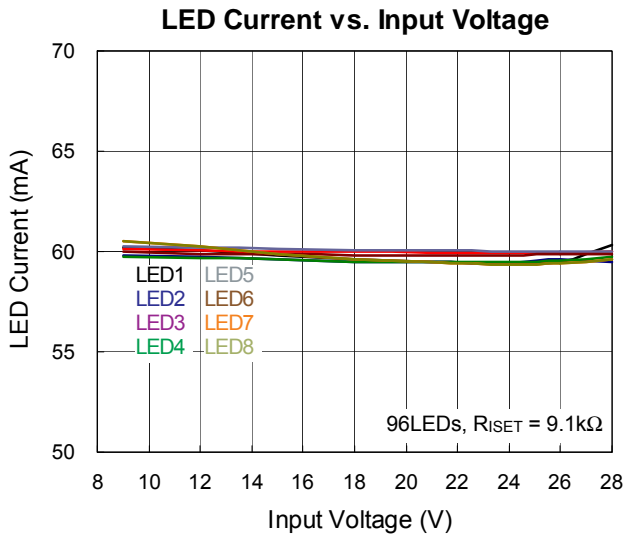

Application Information

The RT8572 is an 8-CH driver controller that delivers well matched LED current to each channel of LED strings. The external N-MOSFET current source will accommodate the power dissipation difference among channels resulting from the forward voltage difference between the LED strings. With high speed current source N-MOSFET drivers, the RT8572 features highly accurate current matching, while also providing very fast turn-on and turn-off times. This allows a very narrow minimum on or off pulse. The RT8572 integrates adjustable switching frequency and soft-start and provides circuitry for over temperature, over voltage, under voltage and current limit protection.

Soft-Start

The RT8572 employs a soft-start feature to limit the inrush current. The soft-start circuit prevents excessive inrush current and input voltage droop. The soft-start time is determined by a capacitor, C_{SS} , connected between SS and GND and charged with a $6\mu A$ constant current as shown in the following equation.

$$t_{SS} (\text{max}) = C_{SS} \times 4.8 \times 10^5 (\text{s})$$

The value of capacitor C_{SS} is user-defined to satisfy the designer' requirement.

Compensation

The regulator loop can be compensated by adjusting the external components connected to the VC pin. The VC pin is the output of the internal error amplifier. The compensation capacitor will adjust the integrator zero to maintain stability and the resistor value will adjust the frequency integrator gain for fast transient response. Typical values of the compensation components are $R_C = 510\Omega$, $C_C = 0.22\mu F$.

LED Connection

The RT8572 equips 8-CH LED drivers and each channel supports up to 15 LEDs. The LED strings are connected from the output of the boost converter to pin LEDx ($x = 1$ to 8) respectively. If one of the LED channel is not in use, the LEDx pin should be opened directly.

Setting and Regulation of LED current

The LED current can be calculated by the following equation :

$$I_{LED} \cong \frac{545.4}{R_{ISET}}$$

where R_{ISET} is the resistor between the Riset pin and GND. This setting is the reference for the LED current at pin LEDx and represents the sensed LED current for each string. The DC/DC converter regulates the LED current according to the setting.

Over Voltage and Under Voltage Protection

The RT8572 integrates Over Voltage Protection (OVP) and Under Voltage Protection (UVP). When the voltage at the OVP/UVP pin rises above the threshold voltage of approximately 1.2V or falls below the threshold voltage of approximately 0.6V, the internal switch will be turned off and STATUS pin will be pulled high. The internal switch will be turned on again once the voltage at the OVP/UVP pin returns to normal range. The output voltage can be clamped at a certain voltage level and can be calculated by the following equations :

$$V_{OUT(OVP)} = V_{OVP} \times \left(1 + \frac{R_{OVP2}}{R_{OVP1}} \right)$$

$$V_{OUT(UVP)} = V_{UVP} \times \left(1 + \frac{R_{OVP2}}{R_{OVP1}} \right)$$

where R_{OVP1} and R_{OVP2} are the resistors in the resistive voltage divider connected to the OVP/UVP pin. If at least one string is in normal operation, the controller will automatically ignore the open strings and continue to regulate the current for the strings in normal operation. Suggested value for R_{OVP2} is up to $3M\Omega$ to prevent loading effect.

LED Short Circuit Protection

The RT8572 integrates LED Short Circuit Protection (SCP). If one of the LED1 to LED8 pin voltages exceeds a threshold of approximately 4.3V during normal operation, the STATUS pin will be pulled high for a fault signal.

STATUS

After the IC is enabled, STATUS will output logic high if LED short/OVP/UV/OTP conditions exist. STATUS will be reset after V_{IN} or EN is re-applied.

Setting the Switching Frequency

The RT8572 switching frequency is programmable from 100kHz to 1MHz by adjusting the oscillator resistor, R_{RT} . The switching frequency can be calculated by the following equation :

$$f_{SW} \cong 100k + \frac{21.6 \times 10^9}{R_{RT}}$$

Current Limit Protection

The RT8572 can sense the R_{SENSE} voltage between the SEN pin and GND to achieve over current protection. The boost converter senses the inductor current during the on period. The duty cycle depends on the current signal and internal slope compensation compared with the error signal. The external switch will be turned off when the current signal is larger than the internal slope compensation. In the off period, the inductor current will decrease until the internal switch is turned on by the oscillator. The current limit value can be calculated by the following equation :

$$\text{Current Limit (A)} \cong \frac{0.5V}{R_{SENSE}}$$

Brightness Control

The RT8572 features a digital dimming control scheme. A very high contrast ratio true digital PWM dimming is achieved by driving the PWM pin with a PWM signal. The recommended PWM frequency is 200Hz to 10kHz, but the LED current cannot be 100% proportional to duty cycle, especially for high frequency and low duty ratio.

Over Temperature Protection

The RT8572 has over temperature protection function to prevent the IC from overheating due to excessive power dissipation. The IC will shut down and the STATUS pin will be pulled high when junction temperature exceeds 150°C. Main converter starts switching after junction temperature cools down by approximately 20°C.

Inductor Selection

The value of the inductance, L, can be approximated by the following equation, where the transition is from Discontinuous Conduction Mode (DCM) to Continuous Conduction Mode (CCM) :

$$L = \frac{D \times (1-D)^2 \times V_{OUT}}{2 \times f \times I_{OUT}}$$

The duty cycle can be calculated as the following equation :

$$D = \frac{V_{OUT} - V_{IN}}{V_{OUT}}$$

where V_{OUT} is the maximum output voltage, V_{IN} is the minimum input voltage, f is the operating frequency, and I_{OUT} is the sum of current from all LED strings.

The boost converter operates in DCM over the entire input voltage range when the inductor value is less than this value, L. With an inductance greater than L, the converter operates in CCM at the minimum input voltage and may be discontinuous at higher voltages.

The inductor must be selected with a saturated current rating that is greater than the peak current as provided by the following equation :

$$I_{PEAK} = \frac{V_{OUT} \times I_{OUT}}{\eta \times V_{IN}} + \frac{V_{IN} \times D \times T}{2 \times L}$$

where η is the efficiency of the power converter.

Diode Selection

Schottky diodes are recommended for most applications because of their fast recovery time and low forward voltage. Power dissipation, reverse voltage rating, and pulsating peak current are important parameters for consideration when making a Schottky diode selection. Make sure that the diode's peak current rating exceeds I_{PEAK} and reverse voltage rating exceeds the maximum output voltage.

Capacitor Selection

The input capacitor reduces current spikes from the input supply and minimizes noise injection to the converter. For general applications, six 4.7μF ceramic capacitors are sufficient. A value higher or lower may be used depending on the noise level from the input supply and the input current to the converter.

It is recommended to choose a ceramic capacitor based on the output voltage ripple requirements. The minimum value of the output capacitor, C_{OUT} , can be calculated by the following equation :

$$C_{OUT} = \frac{I_{OUT} \times D}{\Delta V_{OUT} \times f}$$

where ΔV_{OUT} is the peak-to-peak ripple voltage at the output.

Thermal Considerations

For continuous operation, do not exceed absolute maximum junction temperature. The maximum power dissipation depends on the thermal resistance of the IC package, PCB layout, rate of surrounding airflow, and difference between junction and ambient temperature. The maximum power dissipation can be calculated by the following formula :

$$P_{D(MAX)} = (T_{J(MAX)} - T_A) / \theta_{JA}$$

where $T_{J(MAX)}$ is the maximum junction temperature, T_A is the ambient temperature, and θ_{JA} is the junction to ambient thermal resistance.

For recommended operating condition specifications of the RT8572, the maximum junction temperature is 125°C and T_A is the ambient temperature. The junction to ambient thermal resistance, θ_{JA} , is layout dependent. For SOP-24 packages, the thermal resistance, θ_{JA} , is 90°C/W on a standard JEDEC 51-3 single-layer thermal test board. The maximum power dissipation at $T_A = 25^\circ\text{C}$ can be calculated by the following formula :

$$P_{D(MAX)} = (125^\circ\text{C} - 25^\circ\text{C}) / (90^\circ\text{C/W}) = 1.111\text{W for SOP-24 package}$$

The maximum power dissipation depends on the operating ambient temperature for fixed $T_{J(MAX)}$ and thermal resistance, θ_{JA} . For the RT8572 package, the derating curve in Figure 3 allows the designer to see the effect of rising ambient temperature on the maximum power dissipation.

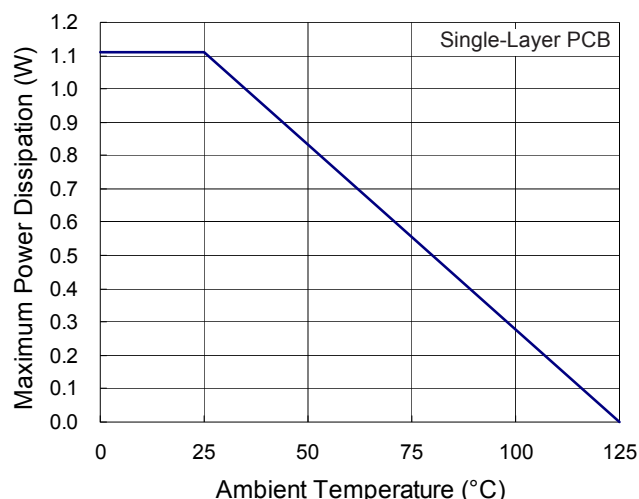

Figure 3. Derating Curve for RT8572 Packages

Layout Considerations

PCB layout is very important for designing switching power converter circuits. The following layout guides should be strictly followed for best performance of the RT8572.

- ▶ The power components L1, D1, C_{IN} , C_{OUT} must be placed as close to the chip as possible to reduce current loop. The PCB trace between power components must be as short and wide as possible.
- ▶ The compensation circuit should be kept away from the power loops and shielded with a ground trace to prevent any noise coupling. Place the compensation components as close to pin 9 as possible, regardless of whether it is R_C or C_C .

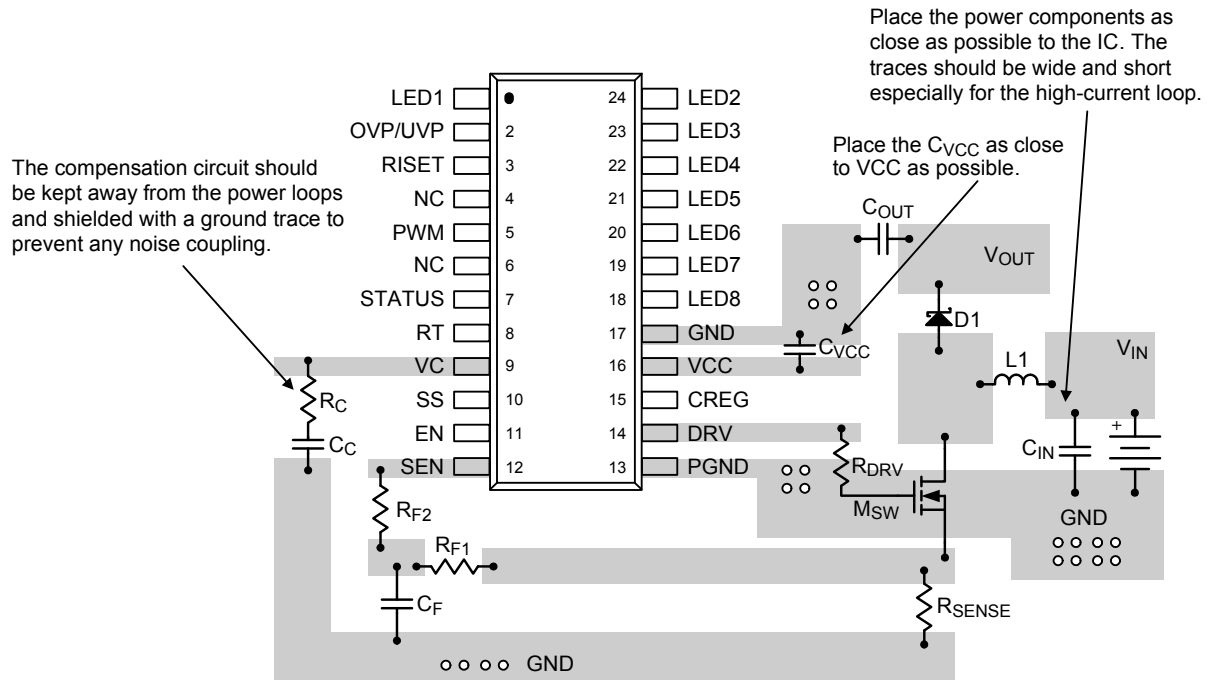
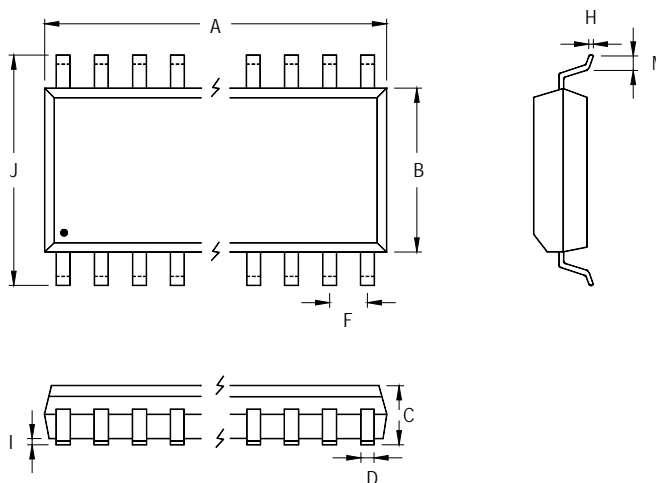

Figure 4. PCB Layout Guide

Outline Dimension



Symbol	Dimensions In Millimeters		Dimensions In Inches	
	Min	Max	Min	Max
A	15.189	15.596	0.598	0.614
B	7.391	7.595	0.291	0.299
C	2.362	2.642	0.093	0.104
D	0.330	0.508	0.013	0.020
F	1.194	1.346	0.047	0.053
H	0.229	0.330	0.009	0.013
I	0.102	0.305	0.004	0.012
J	10.008	10.643	0.394	0.419
M	0.381	1.270	0.015	0.050

24-Lead SOP Plastic Package

Richtek Technology Corporation

Headquarter
 5F, No. 20, Taiyuen Street, Chupei City
 Hsinchu, Taiwan, R.O.C.
 Tel: (8863)5526789 Fax: (8863)5526611

Richtek Technology Corporation

Taipei Office (Marketing)
 5F, No. 95, Minchiuan Road, Hsintien City
 Taipei County, Taiwan, R.O.C.
 Tel: (8862)86672399 Fax: (8862)86672377
 Email: marketing@richtek.com

Information that is provided by Richtek Technology Corporation is believed to be accurate and reliable. Richtek reserves the right to make any change in circuit design, specification or other related things if necessary without notice at any time. No third party intellectual property infringement of the applications should be guaranteed by users when integrating Richtek products into any application. No legal responsibility for any said applications is assumed by Richtek.