

DESCRIPTION

The RTC6689H silicon-germanium (SiGe) power amplifier (PA) is designed to operate in 2.4GHz ISM band, compatible with 802.11b/g wireless LAN system. The Amplifier consists of 3 gain stages with inter-stage matching and build-in input matching network, and a power detector for close loop power control operation. In 802.11g mode (64QAM, 54Mbps), it provides a low EVM (Error-Vector magnitude) of 3% at +19dBm linear output power. The device is packaged in a tiny industry-standard 16-lead surface mount package QFN16 3x3.

FEATURE

- ◆ 3.3V Power Supply
- ◆ Maximum Linear Output Power for 11g usage : +19dBm OFDM
- ◆ Maximum Linear Output Power for 11b usage : +20 dBm QPSK
- ◆ Small signal gain : 32dB
- ◆ On-chip input matching
- ◆ Operation ambient temperature: -40 ~ +120 °C

APPLICATION

- ◆ IEEE 802.11b/g Wireless LAN Application
- ◆ Wireless Local Area Networks (WLAN)
- ◆ ISM System including Automatic Level Control(ALC)
- ◆ TDMA Packet Protocol Radios

PINOUT (top view)

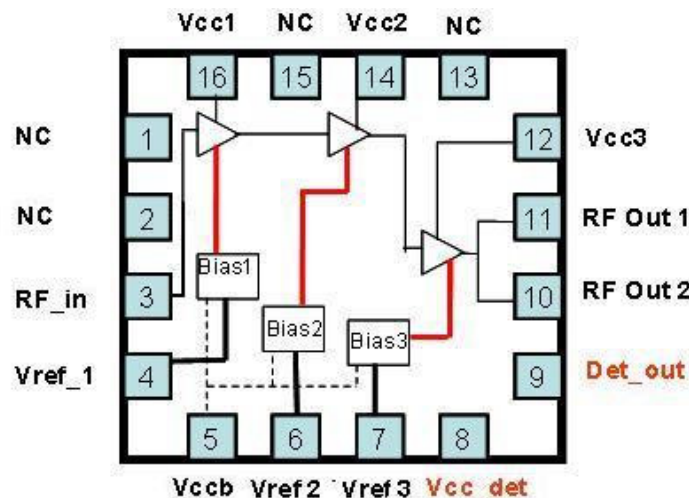

PIN FUNCTION DESCRIPTION

Pin	Function	Description
1	NC	Not connected
2	NC	Not connected
3	RFin	RF input. Matching network is built on chip.
4	Vref1	Bias Control voltage of power stage-1, via R1 to 3.3V
5	Vccb	Power supply for bias circuit, typically 3.3V
6	Vref2	Bias Control voltage of power stage-2, via R2 to 3.3V
7	Vref3	Bias Control voltage of power stage-3, via R3 to 3.3V
8	Vcc_det	Detector reference voltage, typically 3.3V (Not ready yet)
9	Det_out	Detector output voltage for output power index (Not ready yet)
10	RF out 2	RF output 2
11	RF out 1	Same as pin 10
12	Vcc3	Power supply for power stage-3, typically 3.3V
13	NC	Not connected
14	Vcc2	Power supply for power stage-2, typically 3.3V
15	NC	Not connected
16	Vcc1	Power supply for power stage-1, typically 3.3V

ABSOLUTE MAXIMUM RATINGS

PARAMETER	RATING	UNITS
Supply Voltage	-0.5 to +5.0	V
Reference Voltage(Vref)	0.0 to +4.0	V
Input RF Level	10	dBm
Operating Ambient Temperature	-40 to +120	°C
Storage Temperature	-40 to +150	°C

DC ELECTRICAL CHARACTERISTICS

T=25°C, Vcc=3.3v, Freq=2.45GHz

PARAMETER	CONDITION	MIN	TYP	MAX	UNITS
Supply Voltages					
Vcc1		3.0	3.3	3.6	Volts
Vcc2		3.0	3.3	3.6	Volts
Vcc3		3.0	3.3	3.6	Volts
Vref1	R2 =1000 ohm		3.3		Volts
Vref2	R3 =120 ohm		3.3		Volts
Vref3	R4 =1200 ohm		3.3		Volts
Supply Currents					
Icc1 + Icc2 + Icc3 (for 802.11g usage)	Quiescent (no RF) Pout= 19 dBm		135 185		mA
Icc1 + Icc2 + Icc3 (for 802.11b usage)	Quiescent (no RF) Pout= 20 dBm		135 210		mA
Ioff	Standby current		0.02		uA
Iref1	Quiescent (no RF)		1.4		mA
Iref2	Quiescent (no RF)		3.3		mA
Iref3	Quiescent (no RF)		1.1		mA

PARAMETER	CONDITION	MIN	TYP	MAX	UNITS
Det_out (Not ready yet) (Z _{load} = 10 K, Capacitor in parallel = 10 pF)	Output voltage of power detector No RF Pout = 10 dBm Pout = 15 dBm Pout = 19 dBm		0.5 0.80 1.05 1.40		V

AC ELECTRICAL CHARACTERISTICS

T=25°C, Vcc=3.3V, Freq=2.45GHz

PARAMETER	CONDITION	MIN	TYP	MAX	UNITS
Frequency Range		2.4		2.5	GHz
Saturated Output Power			26		dBm
OP1dB			25.3		dBm
Linear efficiency	Measured @ P1dB		27		%
Small Signal Gain	Pin=-30dBm		32		dB
Isolation	"OFF" state				dB
Input VSWR	P _{in} =-30 dBm		2:1		
Linear Pout for 11g usage	Pass 802.11g OFDM 64 QAM EVM < 3%		19		dBm
Pout for Spectral mask	802.11g OFDM 64 QAM		22		dBm
Linear Pout for 11b usage	Pass 802.11b CCK Spectral mask		20		dBm
t _{on} (ramp-on time)	Rise time for 10% to 90% Pout		60		ns

www.Datasheet4U.com

Evaluation Board Schematic

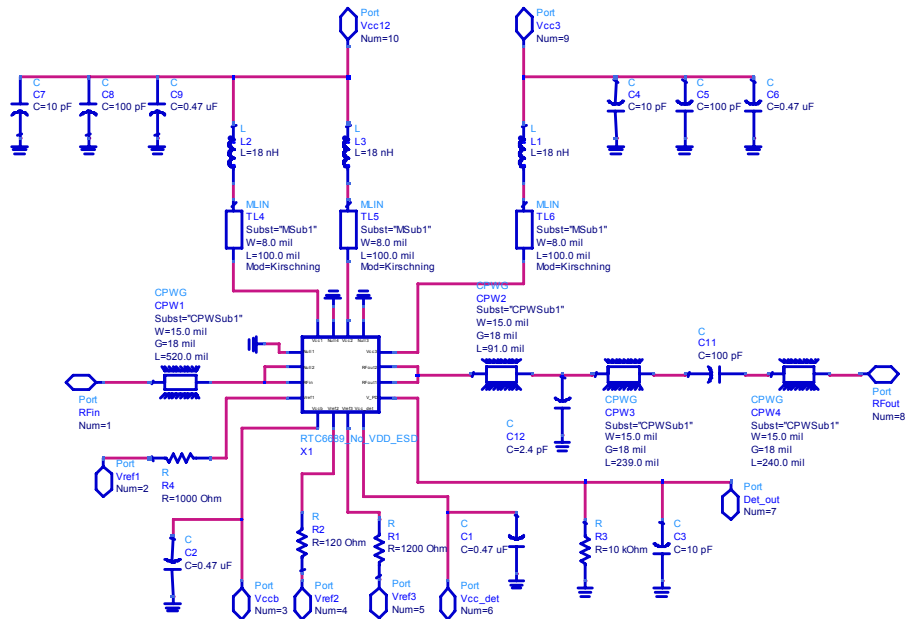

EVB LAYOUT

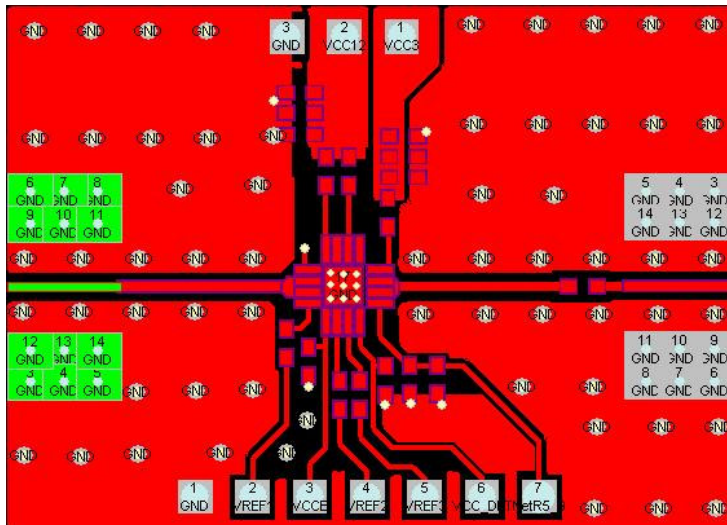

Note : Vcc12, Vcc3 and Vccb are connected together and applied to 3.3V.
 Vref1, Vref2 and Vref3 can be connected together and applied to the other 3.3V.

EVM with OFDM 64QAM

IEEE 802.11a					
Frequency:	2.45 GHz	Signal Level:	20 dBm	External Att:	0.1 dB
Sweep Mode:	Single	Trigger Mode:	Free Run	Trigger Offset:	-10 μ s
Burst Type:	Direct Link Burst	Modulation:	54 Mbps 64 QAM	No. OF Data Symbols:	1/1366

Result Summary						
No. of Bursts	Min	Mean	Limit	Max	Limit	Unit
EVM All Carriers	2.99	3.00	5.62	3.02	5.62	%
	-30.49	-30.45	-25.00	-30.39	-25.00	dB
EVM Data Carriers	3.00	3.02	5.62	3.04	5.62	%
	-30.45	-30.40	-25.00	-30.34	-25.00	dB
EVM Pilot Carriers	2.79	2.82	39.81	2.85	39.81	%
	-31.10	-31.00	-8.00	-30.89	-8.00	dB
IQ Offset	-29.06	-29.04	-15.00	-29.01	-15.00	dB
Gain Imbalance	-0.19	-0.18		-0.17		%
	-0.02	-0.02		-0.01		dB
Quadrature Error	-0.12	-0.11		-0.11		°
Center Frequency Error	-50.75	-53.38	\pm 49000	-56.76	\pm 49000	Hz
Symbol Clock Error	0.73	0.79	\pm 20	0.87	\pm 20	ppm
Burst Power	19.06	19.06		19.06		dBm
Crest Factor	8.15	8.16		8.17		dB

Measurement Complete
Date: 11.MAR.2005 11:33:34

OFDM Spectral Mask

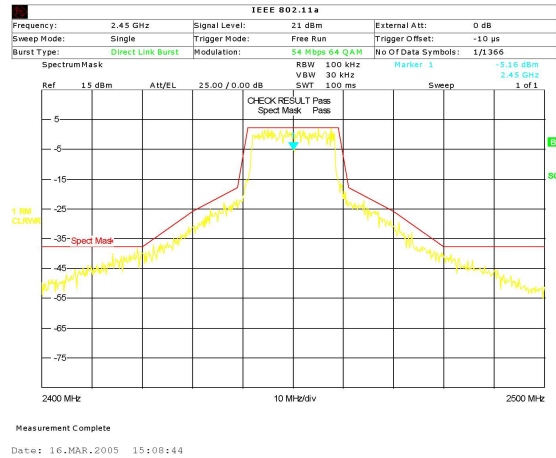

EVM and Spectrum mask of OFDM with 64QAM: $V_{cc1}=V_{cc2}=V_{cc3}=3.3V$,
 $V_{ref1}=V_{ref2}=V_{ref3}=3.3V$, $V_{ccb}=3.3V$

Pout and Gain vs. Pin

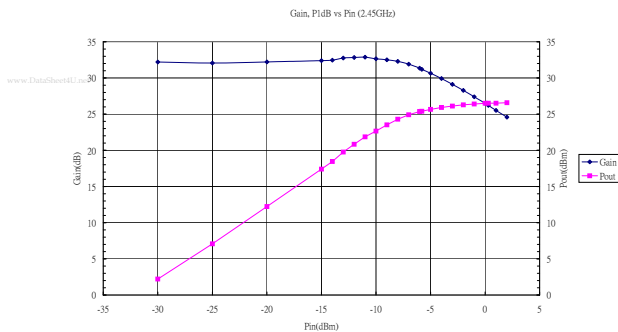

PAE vs. Pout

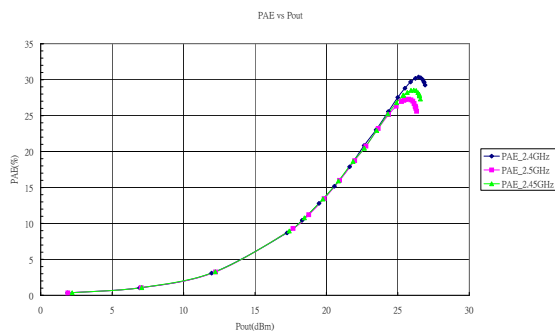

PAE, Pout and Gain measurement: $V_{cc1}=V_{cc2}=V_{cc3}=V_{ccb}=3.3V$,
 $V_{ref1}=V_{ref2}=V_{ref3}=3.3V$

Package

Quad Flat No-Lead Plastic Package (QFN16 3x3)

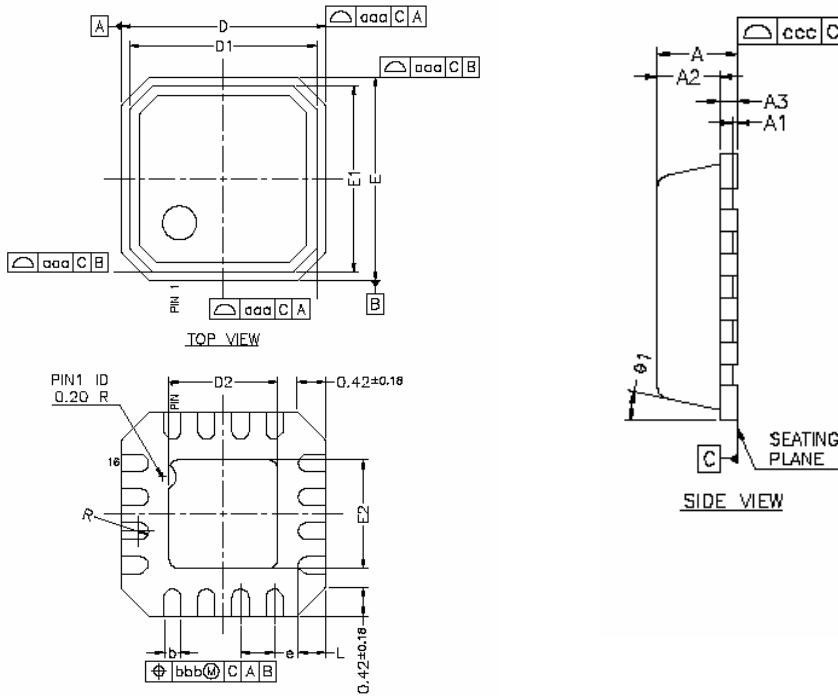

* CONTROLLING DIMENSION : MM

SYMBOL	MILLIMETER			INCH		
	MIN.	NOM.	MAX.	MIN.	NOM.	MAX.
A	0.80	0.85	0.80	0.031	0.033	0.035
A1	0.00	0.02	0.05	0.000	0.002	0.002
A2	---	0.85	0.70	---	0.026	0.028
A3	0.20	REF.	---	0.008	REF.	---
b	0.20	0.25	0.30	0.008	0.010	0.012
D	3.00	bsc	---	0.118	bsc	---
D1	2.75	bsc	---	0.108	bsc	---
D2	1.20	1.40	1.60	0.047	0.055	0.063
E	3.00	bsc	---	0.118	bsc	---
E1	2.75	bsc	---	0.108	bsc	---
E2	1.20	1.40	1.60	0.047	0.055	0.063
L	0.30	0.40	0.50	0.012	0.016	0.020
a	0.50	bsc	---	0.020	bsc	---
$\phi 1$	0'	---	12'	0'	---	12'
R	0.08	---	---	0.004	---	---
TOLERANCES OF FORM AND POSITION						
aaa	0.10	---	---	0.004	---	---
bbb	0.10	---	---	0.004	---	---
ccc	0.05	---	---	0.002	---	---

www.Datasheet4U.com