

RTC7625HE

2.4 – 2.5 GHz, 256 QAM WLAN Front End Module



APR 2018 - Ver. 0.6

Description

The RTC7625HE is a complete WLAN RF front-end module which provides all the functionality of the power amplifier, power detector, filter, single-pole double-throw (SPDT) switch, and low noise amplifier. With all the critical matching integrated, the module is easy to be used in WLAN applications. The device is packaged in a compact 16L QFN 3.0 mm x 3.0 mm x 1.0 mm (max).

Functional Block Diagram

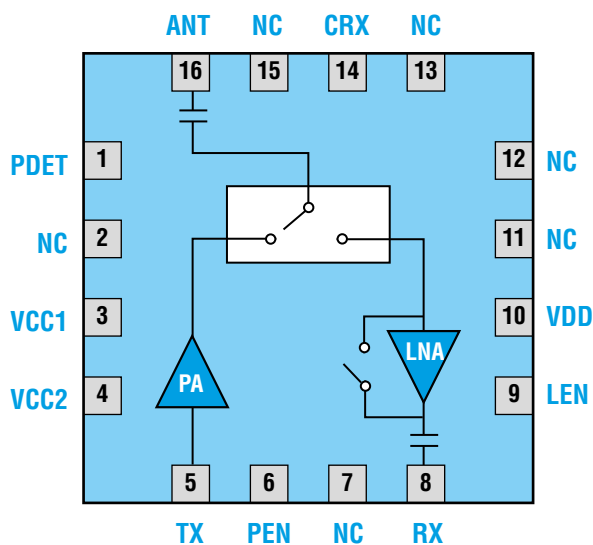

Features

- Frequency range: 2.4 – 2.5 GHz
- 3.3 V or 5 V single supply voltage
- Integrate high performance PA, LPF, LNA with bypass function, and SPDT switch
- Integrated positive slope power detector
- 16L QFN 3.0 mm x 3.0 mm x 1.0mm (max) package
- RoHS Compliant, Pb-free, Halogen Free
- Moisture Sensitivity Level : MSL 3

Applications

- Wi-Fi Applications
- PC Cards, PCMCIA Cards, miniPCI Cards, and PCIe Cards
- Wi-Fi Access Points, Gateways, and Set Top Boxes

Pin Assignments

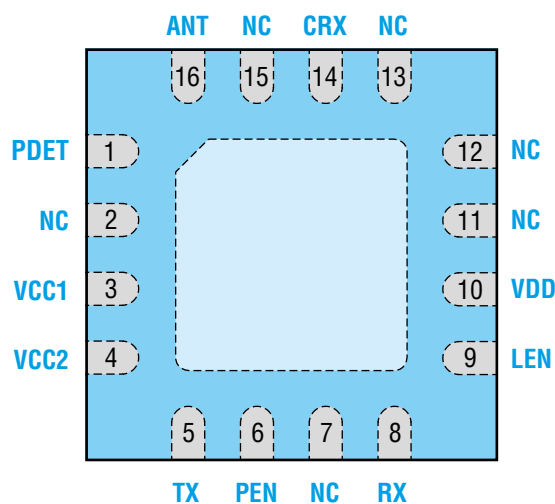

Top View Through Package

Pin No.	Pin Name	Description
1	PDET	PA detector output
3	VCC1	PA supply voltage
4	VCC2	PA supply voltage
5	TX	RF input port for PA
6	PEN	Control voltage for PA and TX switch
8	RX	RF output port for LNA
9	LEN	Control voltage for LNA
10	VDD	LNA supply voltage
14	CRX	Control voltage for RX switch
16	ANT	Antenna output
2, 7, 11, 12, 13, 15	NC	Not connected inside the package For the best performance please connect these pins to ground on PCB
Exposed Paddle		It must be connected to a ground through PCB via for best performance

Absolute Maximum Ratings

Parameter	Symbol	Ratings	Unit
Supply voltage	VCC, VDD	5.5	V
PA Enable Voltage	PEN	4	V
LNA Enable Voltage	LEN	4	V
Switch Control Voltage	CRX	4	V
TX Input Power (50Ω load)	P _{IN_TX}	15	dBm
RX Input Power at ANT Port (50Ω load)	P _{IN_RX}	15	dBm
Operating Temperature	T _A	-40 to +85	°C
Storage Temperature	T _{STG}	-40 to +150	°C

NOTE: Stresses above those conditions listed under Absolute Maximum Ratings may cause permanent damage to the device. This is a stress rating only. Functional operation of the device above those conditions indicated in the Absolute Maximum Ratings is not implied. The functional operation of the device at the conditions in between Recommended Operating Ranges and Absolute Maximum Ratings for extended periods may affect device reliability.

Recommended Operating Ranges

Parameter	Symbol	Min	Typ	Max	Unit
Supply Voltage	VCC, VDD	3.0	3.3 or 5.0	5.5	V
PA Control Voltage (High)	PEN(H)	2.6	3	3.3	V
PA Control Voltage (Low)	PEN(L)	-0.2	0	0.3	V
LNA Control Voltage (High)	LEN(H)	2	3	3.6	V
LNA Control Voltage (Low)	LEN(L)	-0.2	0	0.3	V
Switch Control Voltage (High)	CRX(H)	2	3	3.6	V
Switch Control Voltage (Low)	CRX(L)	-0.2	0	0.3	V

NOTE: Recommended Operating Ranges indicate conditions for which the device is intended to be functional, but does not guarantee specific performance limits.

Truth Table

PEN	LEN	CRX	Mode
High	Low	Low	Transmit
Low	High	High	Receive Gain
Low	Low	High	Receive Bypass
Low	Low	Low	All Off Mode

NOTE: Any operating mode other than described in this Table is not supported.

5V Electrical Specification

Parameter	Symbol	Test Condition	Min	Typ	Max	Unit
Transmit Mode (TX – ANT)						
T _A = +25 °C, VCC = VDD = 5 V, PEN = 3.0 V, LEN = CRX = 0 V. All unused RF ports are terminated in a 50 Ω load, unless otherwise noted						
Operating Frequency	f		2.4		2.5	GHz
Output Power, High Linearity Mode	P _{out}	802.11ac, MCS9, HT40, DEVM = -40 dB	18	20		dBm
		802.11ac MCS9, HT40, DEVM = -35 dB	19	21		dBm
		802.11n, MCS7, HT20, DEVM = -30 dB	21	23		dBm
		802.11n, MCS0 spectral mask compliant	24	26		dBm
		802.11b 1Mbps CCK spectral mask compliant	24	26		dBm
Small Signal Gain	G		24	26	28	dB
Gain Flatness	ΔG	Gain variation over the full band			1	dB
1 dB Output Compression Point	P1dB	1dB gain compression		28		dBm
Input Return Loss	S ₁₁	at TX port	14	17		dB
Output Return Loss	S ₂₂	at ANT port	9	12		dB
Isolation ANT – RX	ISO_1		30	45		dB
Isolation TX – RX	ISO_2		20	25		dB
2nd Harmonics	2fo	802.11b, 1 Mbps P _{out} = +25 dBm		-14		dBm/MHz
3rd Harmonics	3fo	(No external harmonic filter)		-32		dBm/MHz
PA Control Current	I _{PEN}	PEN = 3.0 V, no RF		2		mA
Power Detector Output	P _{det}	P _{out} = 0 dBm		0.12		V
		P _{out} = 10 dBm		0.21		V
		P _{out} = 21 dBm		0.61		V
		P _{out} = 26 dBm		1.12		V
Operating Current	I _{cc}	Quiescent (no RF)		255	290	mA
		P _{out} = 22 dBm		310	345	mA
		P _{out} = 25 dBm		345	385	mA
Stability	S	CW, Pin = 0 dBm, 0.1 ~ 20 GHz, load VSWR = 6:1				All non-harmonically related outputs < -37 dBm/MHz
Ruggedness	R _u	CW, Pin = +10 dBm, 0.1 ~ 20 GHz, load VSWR = 10:1				No Permanent Damage

Parameter	Symbol	Test Condition	Min	Typ	Max	Unit
Switching On/Off Time	ton, toff	On, Off (50% V to 90%/10% RF)		TBD		ns
Receive Gain Mode (ANT – RX)						
T _A = +25 °C, VCC = VDD = 5 V, PEN = 0 V, LEN = CRX = 3.0 V. All unused RF ports are terminated in a 50 Ω load, unless otherwise noted						
Operating Frequency	f		2.4		2.5	GHz
RX Gain	S21	LNA enabled	11.5	13.5		dB
Noise Figure	NF	from ANT to RX port		2.4		dB
Input Return Loss	S11	at ANT port	5.5	7		dB
Output Return Loss	S22	at RX port	11	14		dB
Isolation ANT – TX	ISO			32		dB
Isolation RX – TX	ISO			36		dB
Input P1dB	IP1dB	1dB Gain Compression		0		dBm
Supply Current	I _{DD}	RX Gain Mode		21		mA
Receive Bypass Mode (ANT – RX)						
T _A = +25 °C, VCC = VDD = 5 V, PEN = 0 V, CRX = 3.0 V. LEN = 0 V. All unused RF ports are terminated in a 50 Ω load, unless otherwise noted						
Operating Frequency	f		2.4		2.5	GHz
Gain	S21			-9		dB
Input Return Loss	S11	at ANT port		4		dB
Output Return Loss	S22	at RX port		6		dB

3.3V Electrical Specification

Parameter	Symbol	Test Condition	Min	Typ	Max	Unit
Transmit Mode (TX – ANT)						
T _A = +25 °C, VCC = VDD = 3.3 V, PEN = 3.0 V, LEN = CRX = 0 V. All unused RF ports are terminated in a 50 Ω load, unless otherwise noted						
Operating Frequency	f		2.4		2.5	GHz
Output Power, High Linearity Mode	P _{out}	802.11ac, MCS9, HT40, DEVM = -40 dB	14.5	16.5		dBm
		802.11ac MCS9, HT40, DEVM = -35 dB	15	17		dBm
		802.11n, MCS7, HT20, DEVM = -30 dB	17	19		dBm
		802.11n, MCS0 spectral mask compliant	20	22		dBm
		802.11b 1Mbps CCK spectral mask compliant	21	23		dBm
Small Signal Gain	G		22.5	24.5		dB
Gain Flatness	ΔG	Gain variation over the full band			1	dB
1 dB Output Compression Point	P1dB	1dB gain compression		24		dBm
Input Return Loss	S ₁₁	at TX port	16	19		dB
Output Return Loss	S ₂₂	at ANT port	10	13		dB
Isolation ANT – RX	ISO		30	45		dB
Isolation TX – RX	ISO		21	26		dB
2nd Harmonics	2fo	P _{out} = +22 dBm 1 Mbps, 802.11b (No external harmonic filter)		-18		dBm/MHz
3rd Harmonics	3fo			-35		dBm/MHz
PA Control Current	I _{PEN}	PEN = 3.0 V, no RF		2		mA
Power Detector Output	P _{det}	P _{out} = 0 dBm		0.12		V
		P _{out} = 10 dBm		0.21		V
		P _{out} = 17 dBm		0.42		V
		P _{out} = 23 dBm		0.87		V
Operating Current	I _{cc}	Quiescent (no RF)		225	260	mA
		P _{out} = 19 dBm		265	300	mA
		P _{out} = 23 dBm		305	340	mA
Stability	S	CW, Pin = 0 dBm, 0.1 ~ 20 GHz, load VSWR = 6:1				All non-harmonically related outputs < -36 dBm/MHz
Ruggedness	R _u	CW, Pin = +10 dBm, 0.1 ~ 20 GHz, load VSWR = 10:1				No Permanent Damage

Parameter	Symbol	Test Condition	Min	Typ	Max	Unit
Switching On/Off Time	ton, toff	On, Off (50% V to 90%/10% RF)		TBD		ns
Receive Gain Mode (ANT – RX)						
T _A = +25 °C, VCC = VDD = 3.3 V, PEN = 0 V, LEN = CRX = 3.0 V. All unused RF ports are terminated in a 50 Ω load, unless otherwise noted						
Operating Frequency	f		2.4		2.5	GHz
RX Gain	S21	LNA enabled	11	13		dB
Noise Figure	NF	from ANT to RX port		2.4		dB
Input Return Loss	S11	at ANT port		6		dB
Output Return Loss	S22	at RX port		18		dB
Isolation ANT – TX	ISO			26		dB
Isolation RX – TX	ISO			26		dB
Input P1dB	IP1dB	1dB Gain Compression		0		dBm
Supply Current	I _{DD}	RX Gain Mode		12		mA
Receive Bypass Mode (ANT – RX)						
T _A = +25 °C, VCC = VDD = 3.3 V, PEN = 0 V, CRX = 3.0 V. LEN = 0 V. All unused RF ports are terminated in a 50 Ω load, unless otherwise noted						
Operating Frequency	f		2.4		2.5	GHz
Gain	S21			-9		dB
Input Return Loss	S11	at ANT port		4		dB
Output Return Loss	S22	at RX port		6		dB

Application Circuits

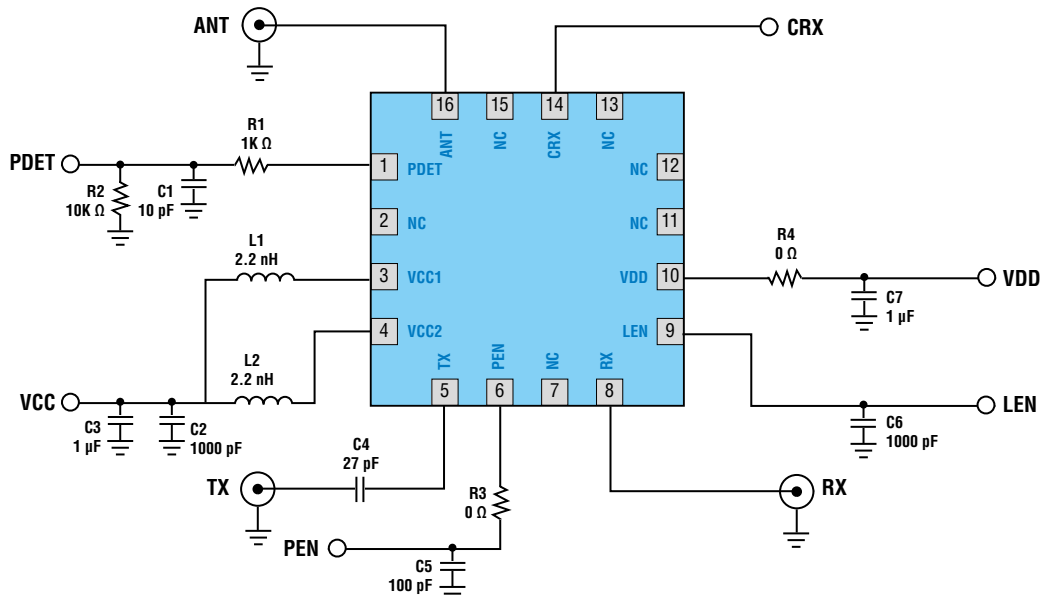

NOTE: Information in the above application is for reference only, and does not guarantee the mass production design of the device.

Evaluation Board Bill of Material

Component	Value	Description	Supplier	Part Number
IC		RTC7625HE	RichWave	
C4	27 pF	DC Blocking capacitor	Walsin	0402N270J500LT
C5	100 pF	De-coupling capacitor	Walsin	0402N101J500LT
C2, C6	1000 pF	De-coupling capacitor	Walsin	0402B102K500CT
C1	10 pF	De-coupling capacitor	Walsin	0402N100J500LT
C3, C7	1 μF	De-coupling capacitor	Walsin	0402X105K6R3CT
L1, L2	2.2 nH	RF choke inductor	ACX	HI0603-1C2N2SNT
R1	1K Ω		Walsin	WR04X1001FTL
R2	10K Ω		Walsin	WR04X1002FTL
R3, R4	0 Ω		Walsin	WR04X00R0PTL

Package Dimensions

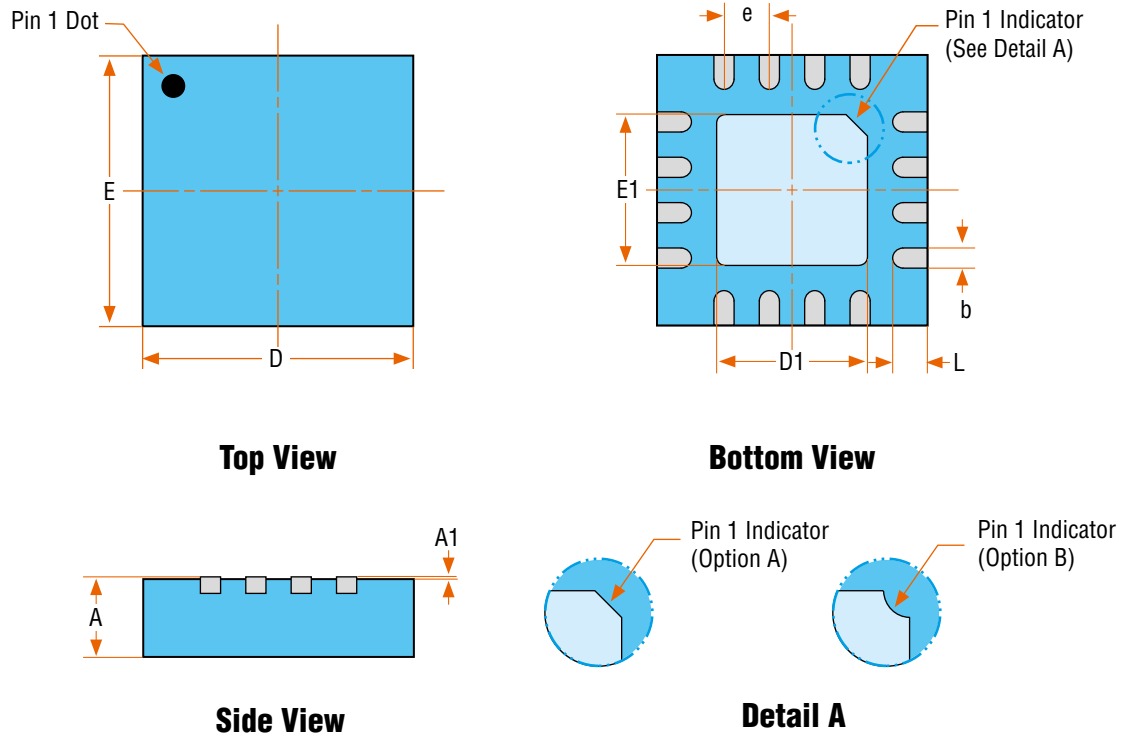

16L QFN 3 X 3 X 1 - C		
SYMBOL	MIN	MAX
A	0.800	1.000
A1	0.000	0.050
b	0.180	0.300
D	2.900	3.100
D1	1.550	1.800
e	0.500 BSC	
E	2.900	3.100
E1	1.550	1.800
L	0.300	0.500

NOTE :

1. All dimensions are measured in millimeters
2. Drawing is not to scale
3. The shape of the Pin 1 Indicator can be either Option A or Option B, but it must be located within the zone indicated

Customer Service

RichWave Technology Corp.

3F, No.1, Alley 20, Lane 407, Sec.2, Tiding Bvd., Neihu Dist., Taipei City 114, Taiwan, R.O.C.

TEL +886-2-87511358 FAX +886-2-66006887

www.richwave.com.tw

Disclaimers

RichWave reserves the right to make changes without further notice to specifications and product descriptions in this document to improve reliability, function or design. RichWave does not assume any liability arising out of the application or use of information or product described in this document. Neither does RichWave convey any license under its intellectual property rights nor licenses to any of circuits described in this document to any third party.

The information in this document is believed to be accurate and reliable and is provided on an “as is” basis, without any express or implied warranty. Any information given in this document does not constitute any warranty of merchantability or fitness for a particular use. The operation of this product is subject to the user’s implementation and design practices. It is the user’s responsibility to ensure that equipment using this product is compliant to all relevant standards.

RichWave’s products are not designed or intended for use in life support equipment, devices or systems, or other critical applications, and are not authorized or warranted for such use.

Copyright © RichWave Technology Corp. All rights reserved.