

HK NATER TECH LIMITED

RTL8188CTV WiFi模块承认书

客户名称

Customer: _____

样品名称

Description: **RTL8188CTV 模块** _____

客户料号

Customer P/N: _____

日期

Date: _____

客户栏 Customer		
核准Approve	审核Auditing	承认Admit

供应商栏 Provider		
核准Approve	审核Auditing	承认Admit

客户名称:

公司地址:

电话:

传真:

联系人:

E-mail:

供方名称: HK NATER TECH LIMITED

公司地址: 深圳市宝安区宝民二路贤基大厦2楼

电话: 0755-61522172/13510620050

传真: 0755-61522171

联系人: 王先生

E-mail: hsdgood@163.com

尊敬的客户: 请收到我公司样品承认书三日内传首页, 谢谢!

RL-UM02BS-8188CTV

Product Specifications

WLAN 11b/g/n USB module (1T1R)

Version: V2.0

Overview

UM02BS V2.0 is a WLAN 11n USB module, which fully supports the features and Functional compliance of IEEE 802.11n, eandistandards.

It supports up to 150Mbps high-speed wireless network connections.

It is designed to provide excellent performance with low power Consumption and enhance the advantages of robust system and cost-effective.

It is targeted at competitive superior performance, better power Management applications.

Features

- * Operates in 2.4 GHz frequency bands
- * 1x1 MIMO technology improves effective throughput and range existing 802.11 b/g products
- * Data rates: up to 150Mbps
- * 802.11e-compatible bursting and I standards
- * BPSK, QPSK, 16 QAM, 64 QAM modulation schemes
- * WEP, TKIP, and AES, WPA, WPA2 hardware encryption schemes

General Specification

Model	RL-UM02BS-8188CTV
Product Name	WLAN 11n USB module
Major Chipset	Realtek RTL8188CTV
Standard	802.11b/g/n, 802.3, 802.3u
Data Transfer Rate	1,2,5.5,6,11,12,18,22,24,30,36,48,54,60,90,120 and maximum of 150Mbps
Modulation Method	BPSK/ QPSK/ 16-QAM/ 64-QAM
Frequency Band	2.4 ~ 2.4835 GHz ISM Band
Spread Spectrum	IEEE 802.11b: DSSS (Direct Sequence Spread Spectrum) IEEE 802.11g/n:OFDM (Orthogonal Frequency Division Multiplexing)
RF Output Power	< 13dBm@11n,< 18dBm@11b,< 14dBm@11g
Operation Mode	Ad hoc, Infrastructure
Receiver Sensitivity	11Mbps -86dBm@8%,54Mbps -73dBm@10%,130Mbps -66dBm@10%
Operation Range	Up to 180 meters in open space
LED	
OS Support	Windows 2000,XP32-64,Vista 32/64,Win7 32/64,Linux,Mac, Android, WIN CE
Security	WEP, TKIP, AES, WPA, WPA2
Interface	USB 2.0
Power Consumption	DC3.3V Maximum power dissipation in 80MA
Operating Temperature	-20 ~ +60° C ambient temperature
Storage Temperature	-20~70°C ambient temperature
Humidity	5 to 90 % maximum (non-condensing)
Dimension	12. 9050 x 12.2 x 1.6mm (LxWxH) +-0.4MM

Dimensions:

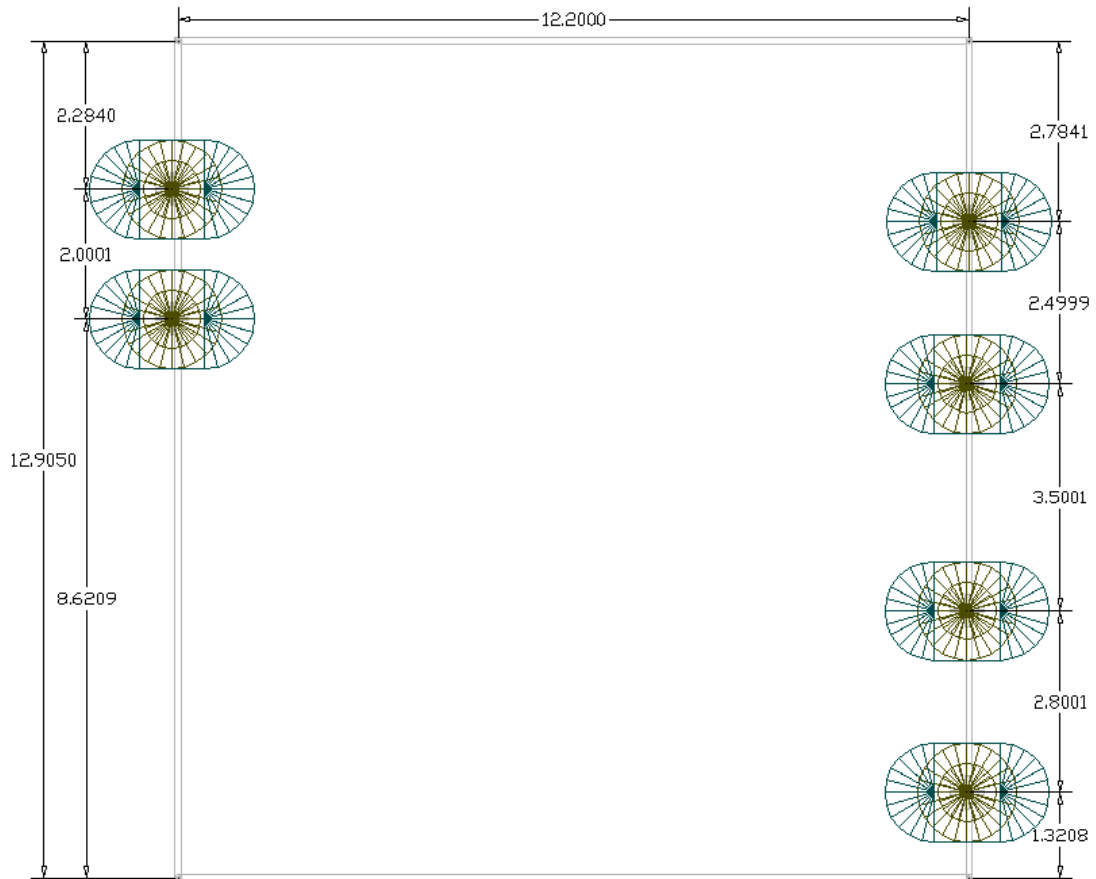

The PCB tolerances within + / -0.4 or so

PIN Definition

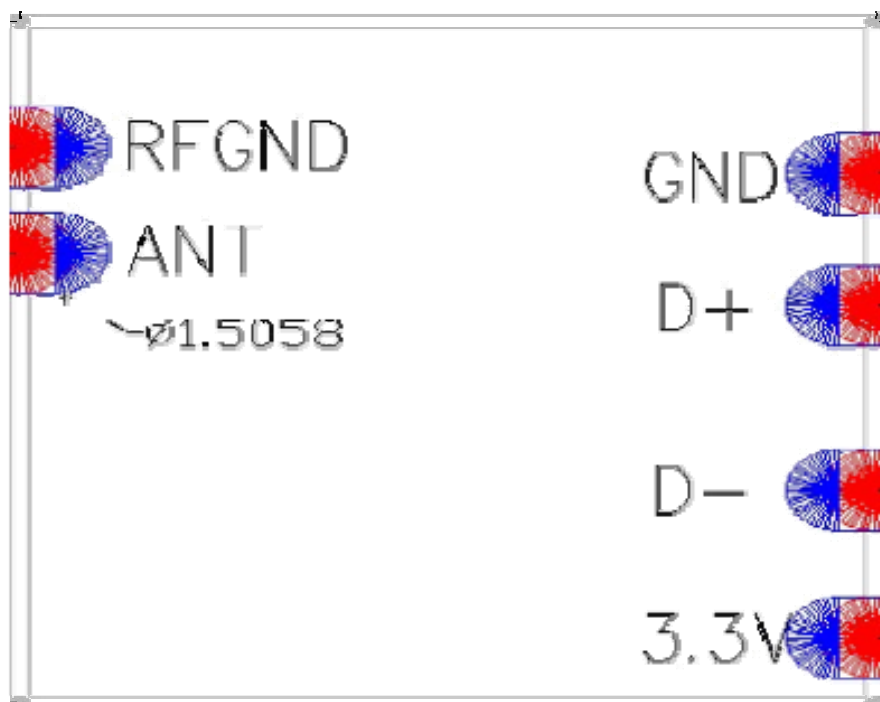

Physical map

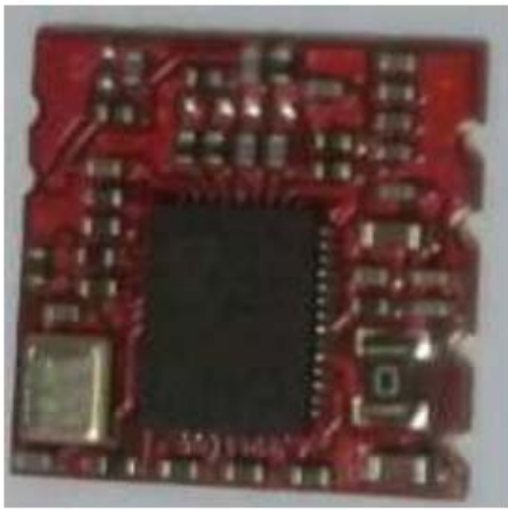

注：我司UM02BS有红、黑、蓝、三种颜色的板，上图标出一种红色供客户参考。

Packaging Appearance Figure

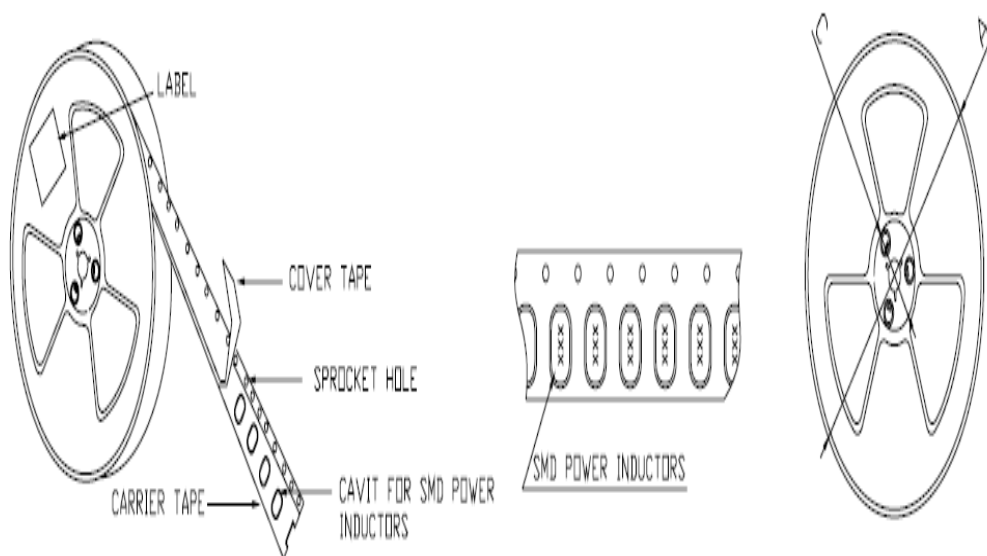

External antenna reference design

此部分需要做50R的单线阻抗

layout走线请走弧型线或直线

参数要根据不同的天线调整

请尽量靠近WIFI模组

距离WIFI模组最远不可以超过20mm

C3请放在模组距离5mm之内

C3位贴0欧电阻也可以

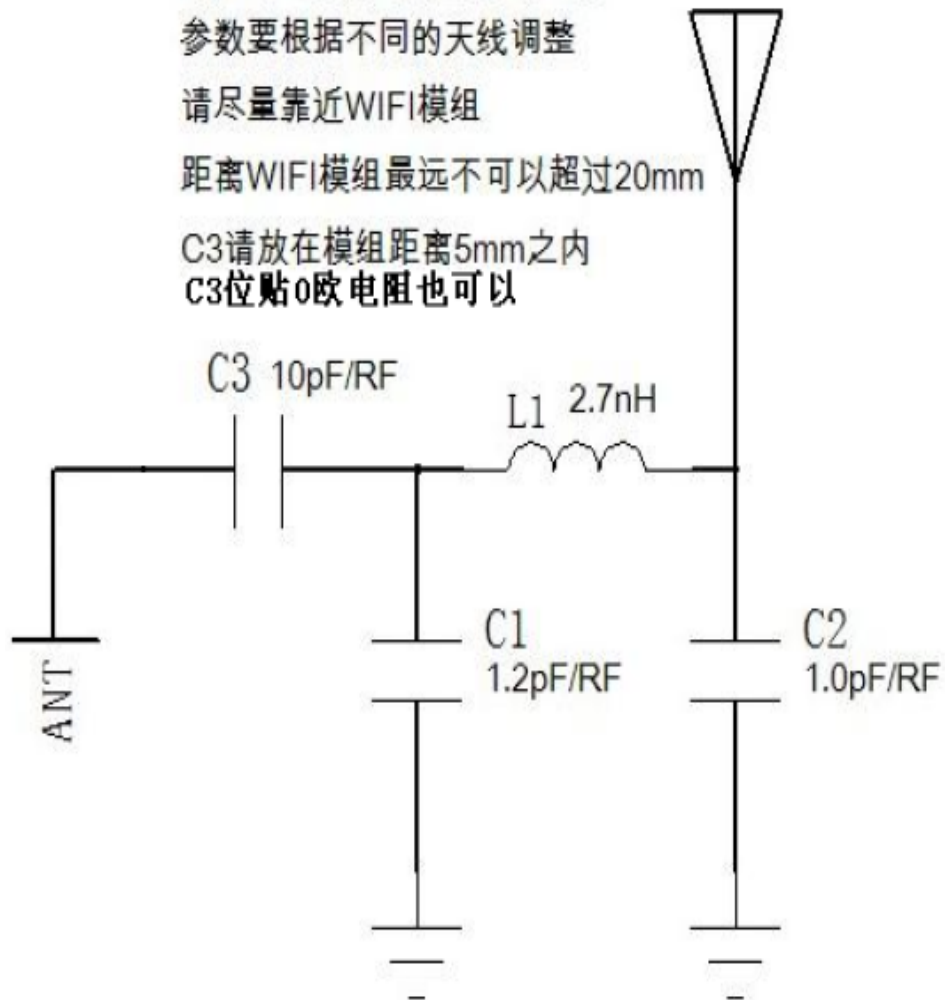

DC Characteristics

Symbol	Parameter	Minimum	Typical	Maximum	Units
VD33A, VD33D	3.3V I/O Supply Voltage	3.1	3.3	3.5	V
VD15A, VD15D	1.5V Supply Voltage	1.4	1.5	1.6	V
IDD33	3.3V Rating Current	-	-	400	mA

Power Consumption

Parameters	Sym	Conditions	Min	Typ	Max	Unit
3.3V Supply Voltage	Vc33		3.1	3.3	3.5	V
1.5V Supply Voltage	Vc15		1.4	1.5	1.6	V
Receiving Tests the biggest receive						
3.3V Current Consumption	Icc33rx	H40MCS7		65		MA
3.3V Current Consumption	Icc33rx	OFDM 54M		70		MA
Transmission Biggest transmission test						
3.3V Current Consumption	Icc33tx	H40 MCS7		80		MA
3.3V Current Consumption	Icc33tx	OFDM 54M		85		MA
The depth waits for an opportunity	Icc33tx/rx			2		MA
Deep sleep	Ic33tx/rx			2		MA

USB interface electrical characteristics

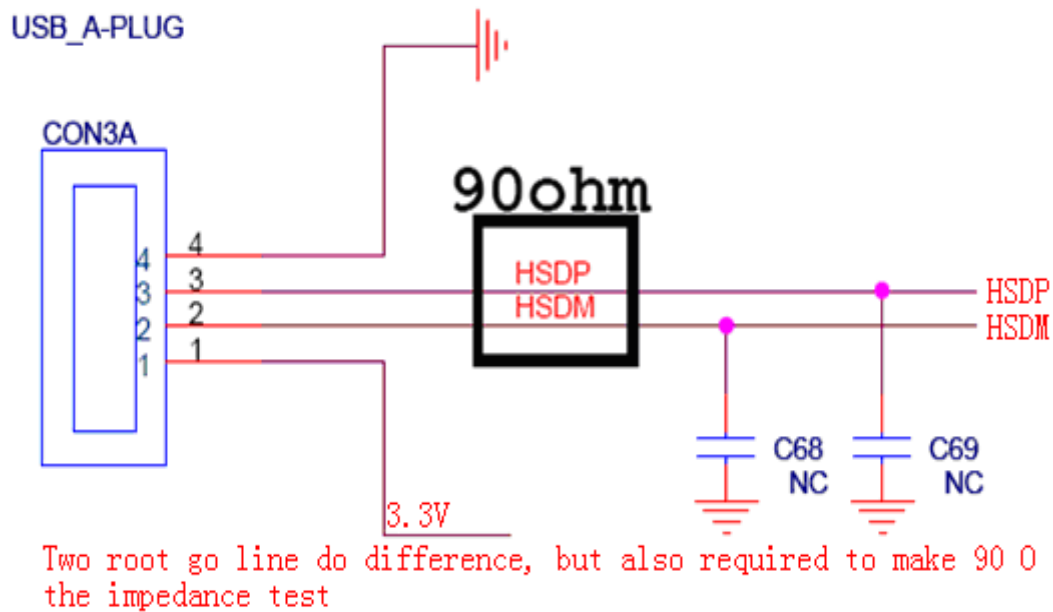

贴片 WIFI 模块装机的前注意事项:

- 1、客户在开钢网时一定要将 WIFI 模块焊盘的孔开大，请按 1 比 1 再向外扩大 0.7Mm 比例来开，厚度按 0.12Mm。
- 2、WIFI 模块在上线贴片前一定要烘烤 12 个小时以上，温度在 120 度+-5 度。
- 3、烘烤 OK 后建议马上上线，不要一烘烤 OK 后就将全部 WIFI 模块拿出烘烤箱，建议每小时贴多少拿多少出来。
- 4、有需要拿 WIFI 模时一定要不要光着手去拿 WIFI 模块，一定要戴上手套及静电环。
- 5、过炉温度要根据客户主板的大小而定，一般像贴在平板电脑上 250+-5 度。