

# REALTEK

***NOT FOR PUBLIC RELEASE***

## RTL8188RE-GR

### SINGLE-CHIP IEEE 802.11b/g/n 1T1R WLAN CONTROLLER w/PCI EXPRESS INTERFACE

## DATASHEET

(CONFIDENTIAL: Development Partners Only)

Rev. 1.0

28 May 2010

Track ID: JATR-2265-11



Realtek Semiconductor Corp.

No. 2, Innovation Road II, Hsinchu Science Park, Hsinchu 300, Taiwan

Tel.: +886-3-578-0211. Fax: +886-3-577-6047

[www.realtek.com](http://www.realtek.com)

**COPYRIGHT**

©2010 Realtek Semiconductor Corp. All rights reserved. No part of this document may be reproduced, transmitted, transcribed, stored in a retrieval system, or translated into any language in any form or by any means without the written permission of Realtek Semiconductor Corp.

**DISCLAIMER**

Realtek provides this document “as is”, without warranty of any kind. Realtek may make improvements and/or changes in this document or in the product described in this document at any time. This document could include technical inaccuracies or typographical errors.

**TRADEMARKS**

Realtek is a trademark of Realtek Semiconductor Corporation. Other names mentioned in this document are trademarks/registered trademarks of their respective owners.

**USING THIS DOCUMENT**

This document is intended for the software engineer’s reference and provides detailed programming information.

Though every effort has been made to ensure that this document is current and accurate, more information may have become available subsequent to the production of this guide.

**REVISION HISTORY**

Revision	Release Date	Summary
1.0	2010/05/28	First release.

---

## Table of Contents

---

<b>1. GENERAL DESCRIPTION .....</b>	<b>1</b>
<b>2. FEATURES .....</b>	<b>2</b>
<b>3. APPLICATION DIAGRAM.....</b>	<b>4</b>
3.1. SINGLE-BAND 11N (1X1) SOLUTION (11N 1X1 MAC/BB/RF) .....	4
3.2. SINGLE-BAND 11N (1X1) SOLUTION (11N 1X1 MAC/BB/RF) WITH ANTENNA DIVERSITY .....	4
<b>4. PIN ASSIGNMENTS.....</b>	<b>5</b>
4.1. PACKAGE IDENTIFICATION .....	5
<b>5. PIN DESCRIPTIONS.....</b>	<b>6</b>
5.1. PCI EXPRESS TRANSCEIVER INTERFACE .....	6
5.2. EEPROM INTERFACE .....	6
5.3. POWER PINS .....	7
5.4. RF INTERFACE .....	7
5.5. LED INTERFACE.....	7
5.6. CLOCK AND OTHER PINS.....	8
<b>6. ELECTRICAL AND THERMAL CHARACTERISTICS.....</b>	<b>9</b>
6.1. TEMPERATURE LIMIT RATINGS .....	9
6.2. DC CHARACTERISTICS .....	9
<b>7. MECHANICAL DIMENSIONS.....</b>	<b>10</b>
7.1. MECHANICAL DIMENSIONS NOTES .....	11
<b>8. ORDERING INFORMATION .....</b>	<b>12</b>

---

---

## List of Tables

---

TABLE 1.	PCI EXPRESS TRANSCEIVER INTERFACE .....	6
TABLE 2.	EEPROM INTERFACE .....	6
TABLE 3.	POWER PINS .....	7
TABLE 4.	RF INTERFACE .....	7
TABLE 5.	LED INTERFACE.....	7
TABLE 6.	CLOCK AND OTHER PINS .....	8
TABLE 7.	TEMPERATURE LIMIT RATINGS .....	9
TABLE 8.	DC CHARACTERISTICS .....	9
TABLE 9.	ORDERING INFORMATION.....	12

---

## List of Figures

---

FIGURE 1.	SINGLE-BAND 11N (1X1) SOLUTION (11N 1X1 MAC/BB/RF) .....	4
FIGURE 2.	SINGLE-BAND 11N (1X1) SOLUTION (11N 1X1 MAC/BB/RF) WITH ANTENNA DIVERSITY.....	4
FIGURE 3.	PIN ASSIGNMENTS.....	5

---

## 1. General Description

The Realtek RTL8188RE-GR is a highly integrated single-chip Wireless LAN (WLAN) PCI Express network interface controller compatible with the 802.11n specification. It combines a MAC, a 1T1R capable baseband, and RF in a single chip. The RTL8188RE provides a complete solution for a high throughput performance wireless client.

The RTL8188RE baseband implements Orthogonal Frequency Division Multiplexing (OFDM) with 1 transmit and 1 receive path and is compatible with the IEEE 802.11n specification 2.0. Features include one spatial stream transmission, short guard interval (GI) of 400ns, spatial spreading, and transmission over 20MHz and 40MHz bandwidth.

For legacy compatibility, Direct Sequence Spread Spectrum (DSSS), Complementary Code Keying (CCK) and OFDM baseband processing are included to support all IEEE 802.11b and 802.11g data rates. Differential phase shift keying modulation schemes, DBPSK and DQPSK with data scrambling capability, are available, and CCK provides support for legacy data rates, with long or short preamble. The high-speed FFT/IFFT paths, combined with BPSK, QPSK, 16QAM, and 64QAM modulation of the individual subcarriers and rate compatible punctured convolutional coding with coding rate of 1/2, 2/3, 3/4, and 5/6, provide higher data rates of 54Mbps and 150Mbps for IEEE 802.11g and 802.11n OFDM respectively.

The RTL8188RE builds in an enhanced signal detector, an adaptive frequency domain equalizer, and a soft-decision Viterbi decoder to alleviate severe multi-path effects and mutual interference in the reception of multiple streams. Robust interference detection and suppression are provided to protect against Bluetooth, cordless phone, and microwave oven interference.

Efficient IQ-imbalance, DC offset, phase noise, frequency offset, and timing offset compensations are provided for the radio frequency front-end. Selectable digital transmit and receive FIR filters are provided to meet transmit spectrum mask requirements and to reject adjacent channel interference, respectively.

The RTL8188RE supports fast receiver Automatic Gain Control (AGC) with synchronous and asynchronous control loops among antennas, antenna diversity functions, and adaptive transmit power control function to obtain the better performance in the analog portions of the transceiver.

The RTL8188RE MAC supports 802.11e for multimedia applications, 802.11i for security, and 802.11n for enhanced MAC protocol efficiency. Using packet aggregation techniques such as A-MPDU with BA and A-MSDU, protocol efficiency is significantly improved. Power saving mechanisms such as Legacy Power Save, and U-APSD, and APSD, reduce the power wasted during idle time, and compensates for the extra power required to transmit OFDM. The RTL8188RE provides simple legacy and 20MHz/40MHz co-existence mechanisms to ensure backward and network compatibility.

## 2. Features

### General

- 64-pin QFN
- CMOS MAC, Baseband PHY, and RF in a single chip for IEEE 802.11b/g/n compatible WLAN
- Complete 802.11n solution for 2.4GHz band
- 72.2Mbps receive PHY rate and 72.2Mbps transmit PHY rate using 20MHz bandwidth
- 150Mbps receive PHY rate and 150Mbps transmit PHY rate using 40MHz bandwidth
- Compatible with 802.11n specification
- Backward compatible with 802.11b/g devices while operating in 802.11n mode

### Host Interface

- Complies with PCI Express Base Specification Revision 1.1

### Standards Supported

- IEEE 802.11b/g/n compatible WLAN
- IEEE 802.11e QoS Enhancement (WMM)
- IEEE 802.11h TPC, Spectrum Measurement
- 802.11i (WPA, WPA2). Open, shared key, and pair-wise key authentication services
- Cisco Compatible Extensions (CCX) for WLAN devices

### MAC Features

- Frame aggregation for increased MAC efficiency (A-MSDU, A-MPDU)
- Low latency immediate High-Throughput Block Acknowledgement (HT-BA)
- Long NAV for media reservation with CF-End for NAV release
- PHY-level spoofing to enhance legacy compatibility
- Power saving mechanism
- Channel management and co-existence
- Multiple BSSID feature allows the RTL8188RE to assume multiple MAC identities when used as a wireless bridge
- Transmit Opportunity (TXOP) Short Inter-Frame Space (SIFS) bursting for higher multimedia bandwidth

### Peripheral Interfaces

- General Purpose Input/Output (11 pins)
- 4-wire EEPROM control interface (93C46)
- Three configurable LED pins
- Configurable Bluetooth Coexistence Interface

*Continued on next page...*

**PHY Features**

- IEEE 802.11n OFDM
- One Transmit and one Receive path (1T1R)
- 20MHz and 40MHz bandwidth transmission
- Short Guard Interval (400ns)
- DSSS with DBPSK and DQPSK, CCK modulation with long and short preamble
- OFDM with BPSK, QPSK, 16QAM, and 64QAM modulation.  
Convolutional Coding Rate: 1/2, 2/3, 3/4, and 5/6
- Maximum data rate 54Mbps in 802.11g and 150Mbps in 802.11n
- Switch diversity for DSSS/CCK
- Hardware antenna diversity
- Selectable receiver FIR filters
- Programmable scaling in transmitter and receiver to trade quantization noise against increased probability of clipping
- Fast receiver Automatic Gain Control (AGC)
- On-chip ADC and DAC

### 3. Application Diagram

#### 3.1. Single-Band 11n (1x1) Solution (11n 1x1 MAC/BB/RF)

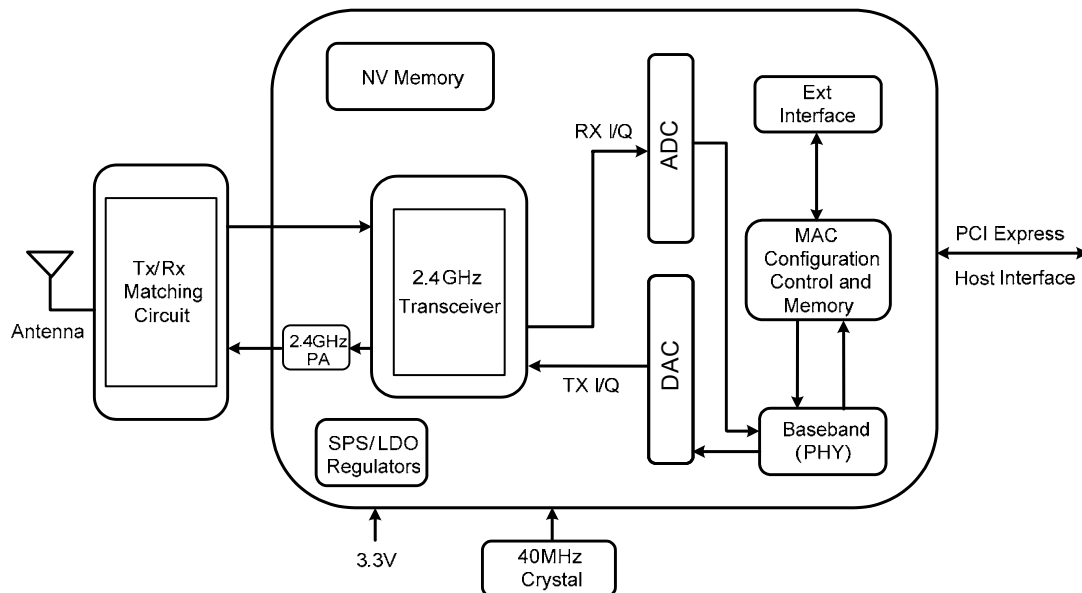

Figure 1. Single-Band 11n (1x1) Solution (11n 1x1 MAC/BB/RF)

#### 3.2. Single-Band 11n (1x1) Solution (11n 1x1 MAC/BB/RF) with Antenna Diversity

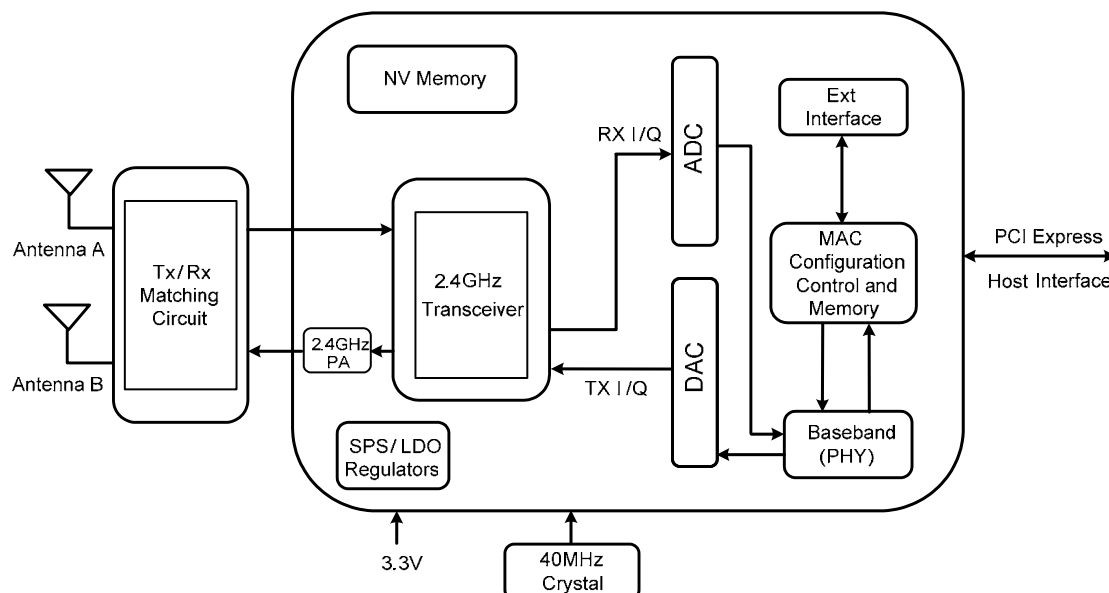

Figure 2. Single-Band 11n (1x1) Solution (11n 1x1 MAC/BB/RF) with Antenna Diversity



## 4. Pin Assignments

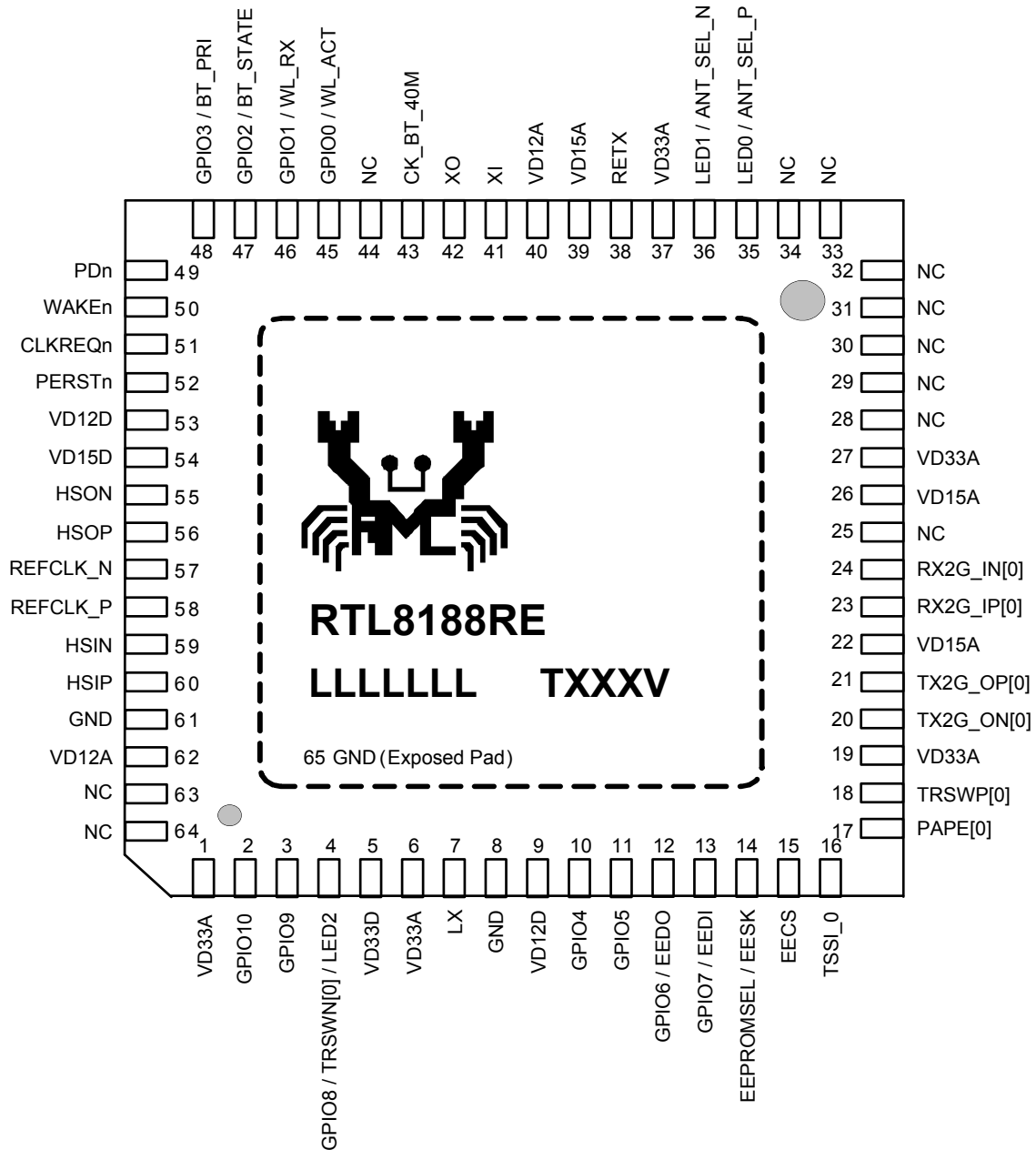

Figure 3. Pin Assignments

### 4.1. Package Identification

‘Green’ package is indicated by a ‘G’ in the location marked ‘T’ in Figure 3.

## 5. Pin Descriptions

The following signal type codes are used in the tables:

I: Input	O: Output
T/S: Tri-State bi-directional input/output pin	S/T/S: Sustained Tri-State
O/D: Open Drain	P: Power pin

### 5.1. PCI Express Transceiver Interface

**Table 1. PCI Express Transceiver Interface**

Symbol	Type	Pin No	Description
HSIN/HSIP	I	59/60	PCI Express Receive Differential Pair
HSON/HSOP	O	55/56	PCI Express Transmit Differential Pair
REFCLK_N/REFCLK_P	I	57/58	PCI Express Differential Reference Clock Source: 100MHz $\pm$ 300ppm
CLKREQn	O	51	Reference Clock Request Signal This signal is used by the RTL8188RE to request starting of the PCI Express reference clock
WAKEn	O/D	50	Power Management Event: Open drain, active low. Used to reactivate the PCI Express slot's main power rails and reference clocks.
PERSTn	I	52	PCI Express Reset Signal: Active low. When the PERSTB is asserted at power-on state, the RTL8188RE returns to a pre-defined reset state and is ready for initialization and configuration after the de-assertion of the PERSTB.

### 5.2. EEPROM Interface

**Table 2. EEPROM Interface**

Symbol	Type	Pin No	Description
EEPROMSEL/EESK	O	14	EESK in 93C46 Programming or Auto-Load Mode
EEDI/GPIO7	O	13	EEDI in 93C46 Programming or Auto-Load Mode
EEDO/GPIO6	IO	12	EEDO in 93C46 Programming or Auto-Load Mode
EECS	O	15	EEPROM Chip Select

### 5.3. Power Pins

**Table 3. Power Pins**

Symbol	Type	Pin No	Description
LX	P	7	Switching Regulator Output
VD33A	P	1, 6, 19, 27, 37	VDD 3.3V for Analog
VD33D	P	5	VDD3.3V for Digital
VD15A	P	22, 26, 39	VDD 1.5V for Analog
VD15D	P	54	VDD 1.5V for Digital
VD12A	P	40, 62	Analog 1.2V Regulator Output
VD12D	P	9, 53	Digital 1.2V Regulator Output
GND	P	8, 61	Ground
RETX	P	38	24k (1%) Precision Resistor for Bandgap

### 5.4. RF Interface

**Table 4. RF Interface**

Symbol	Type	Pin No	Description
TRSWN[0]/GPIO8/LED2	O	4	Transmit/Receive Path Select 0 Shared with LED2; can be selected by control register
PAPE[0]	O	17	2.4GHz Transmit Power Amplifier Power Enable 0
TRSWP[0]	O	18	Transmit/Receive Path Select 0
TX2G_ON[0]	O	20	RF TX0 Negative Signal
TX2G_OP[0]	O	21	RF TX0 Positive Signal
RX2G_IP[0]	I	23	RF RX0 Positive Signal
RX2G_IN[0]	I	24	RF RX0 Negative Signal
ANT_SEL_P/LED0	O	35	Antenna Control Positive Signal Shared with LED0; can be selected by control register
ANT_SEL_N/LED1	O	36	Antenna Control Negative Signal Shared with LED1; can be selected by control register

### 5.5. LED Interface

**Table 5. LED Interface**

Symbol	Type	Pin No	Description
LED0/ANT_SEL_P	O	35	LED Pins (Active Low) Shared with ANT_SEL_P; can be selected by control register
LED1/ANT_SEL_N	O	36	LED Pins (Active Low) Shared with ANT_SEL_N; can be selected by control register
LED2/TRSWN[0]/GPIO8	O	4	LED Pins (Active Low) Shared with TRSWN[0] or GPIO8, can be selected by control register

## 5.6. Clock and Other Pins

**Table 6. Clock and Other Pins**

Symbol	Type	Pin No	Description
XI	I	41	40MHz OSC Input Input of 40MHz Crystal Clock Reference
XO	O	42	Output of 40MHz Crystal Clock Reference
CK_BT_40M	O	43	Buffered 40M Clock Outputs for Other Peripheral IC
PDn	I	49	This Pin Can Externally Shutdown the RTL8191SE-VA1 (no requirement for Extra Power Switch) This pin can also support the WLAN Radio-off function with host interface remaining connected.
GPIO0/WL_ACT	IO	45	General Purpose Input/Output Pin or Bluetooth Coexistence WL_ACT Pin The WL_ACT signal indicates when the WLAN is either transmitting or receiving in the 2.4GHz ISM band.
GPIO1/WL_RX	IO	46	Trap Function: Weakly pull high at power on to turn on CK_BT_40M. General Purpose Input/Output Pin or Bluetooth Coexistence WL_RX Pin WL_RX is an indicator for wireless LAN RX activity.
GPIO2/BT_STATE	IO	47	General Purpose Input/Output Pin or Bluetooth Coexistence BT_STAT Pin The BTSTAT signal indicates when normal Bluetooth packets are being transmitted or received.
GPIO3/BT_PRI	IO	48	General Purpose Input/Output Pin or Bluetooth Coexistence BT_PRI Pin The BT_PRI signal indicates when a high priority Bluetooth packet is being transmitted or received.
GPIO4	IO	10	General Purpose Input/Output Pin
GPIO5	IO	11	General Purpose Input/Output Pin
GPIO6/EEDO	IO	12	General Purpose Input/Output Pin or EEPROM Interface EEDO Signal
GPIO7/EEDI	IO	13	General Purpose Input/Output Pin or EEPROM Interface EEDI Signal
GPIO8/ TRSWN[0]/LED2	IO	4	General Purpose Input/Output Pin, RF TX/RX Path Select, and LED2
GPIO9	IO	3	General Purpose Input/Output Pin
GPIO10	IO	2	General Purpose Input/Output Pin
TSSI_0	I	16	Transmit Signal Strength Indication from External Power Amplifier
NC	-	25, 28, 29, 30, 31, 32, 33, 34, 44, 63, 64	Not Connected

## 6. Electrical and Thermal Characteristics

### 6.1. Temperature Limit Ratings

Table 7. Temperature Limit Ratings

Parameter	Minimum	Maximum	Units
Storage Temperature	-55	+125	°C
Ambient Operating Temperature	0	70	°C
Junction Temperature	0	125	°C

### 6.2. DC Characteristics

Table 8. DC Characteristics

Symbol	Parameter	Minimum	Typical	Maximum	Units
VD33A, VD33D	3.3V I/O Supply Voltage	3.0	3.3	3.6	V
VD12A, VD12D	1.2V Core Supply Voltage	1.10	1.2	1.32	V
VD15A, VD15D	1.5V Supply Voltage	1.425	1.5	1.575	V
IDD33	3.3V Rating Current	-	-	600	mA

## 7. Mechanical Dimensions

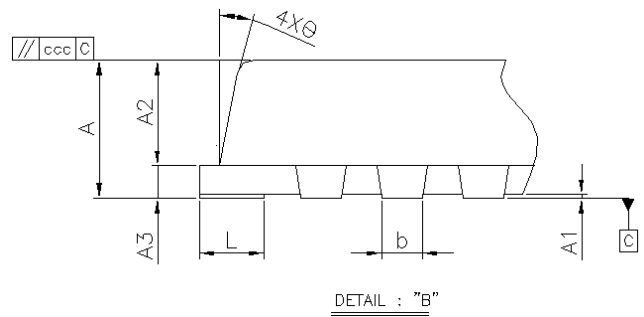
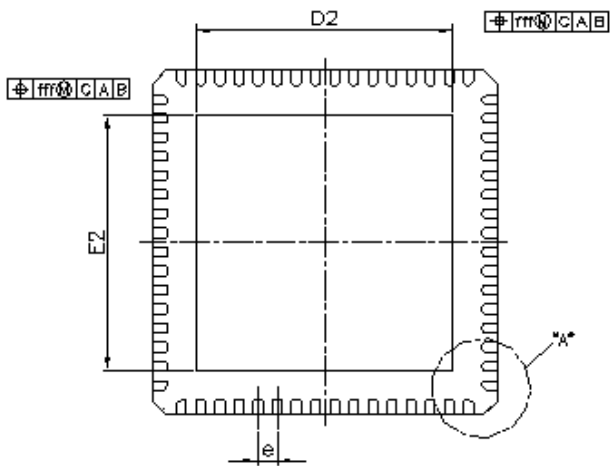
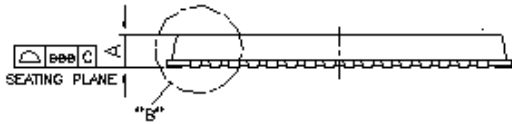
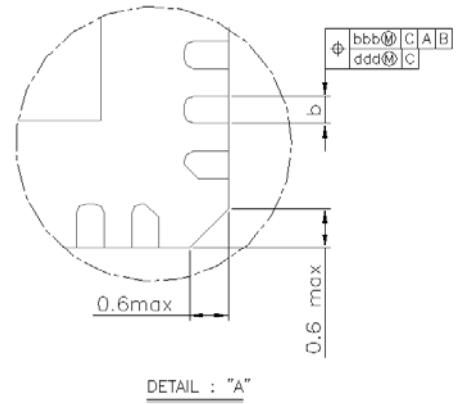
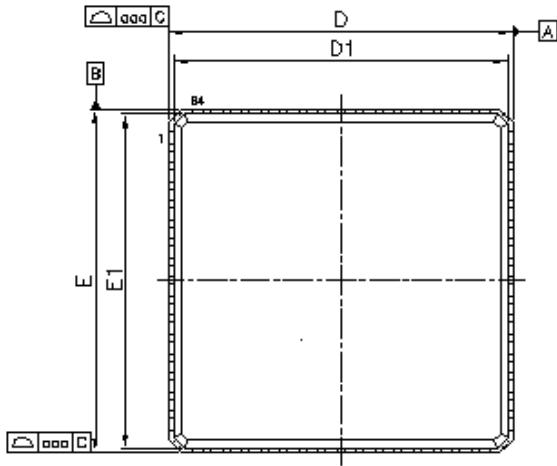

## 7.1. Mechanical Dimensions Notes

Symbol	Dimension in mm			Dimension in inch		
	Min	Nom	Max	Min	Nom	Max
A	0.75	0.85	1.00	0.030	0.034	0.039
A1	0.00	0.02	0.05	0.000	0.001	0.002
A2	0.55	0.65	0.80	0.022	0.026	0.032
A <sub>3</sub>	0.20REF			0.008REF		
b	0.18	0.25	0.30	0.007	0.010	0.012
D/E	9.00BSC			0.354BSC		
D <sub>1</sub> /E <sub>1</sub>	8.75BSC			0.344BSC		
D2/E2	5.25	5.50	5.75	0.206	0.216	0.226
e	0.50BSC			0.020BSC		
L	0.30	0.40	0.50	0.012	0.016	0.020
θ	0°	-	14°	0°	-	14°
aaa	-	-	0.15	-	-	0.006
bbb	-	-	0.10	-	-	0.004
ccc	-	-	0.10	-	-	0.004
ddd	-	-	0.05	-	-	0.002
eee	-	-	0.08	-	-	0.003
fff	-	-	0.10	-	-	0.004

Note1: DIMENSIONS D1 AND E1 DO NOT INCLUDE MOLD PROTRUSION.

Note2: CONTROLLING DIMENSION: MILLIMETER (mm).

Note3: REFERENCE DOCUMENT: JEDEC MO-220.

## 8. Ordering Information

**Table 9. Ordering Information**

Part Number	Package	Status
RTL8188RE-GR	QFN-64, 'Green' Package	Mass Production

*Note: See page 5 for package identification.*

---

**Realtek Semiconductor Corp.****Headquarters**

No. 2, Innovation Road II, Hsinchu Science Park,  
Hsinchu 300, Taiwan, R.O.C.

Tel: 886-3-5780211 Fax: 886-3-5776047

[www.realtek.com](http://www.realtek.com)