

RTL8711AM 802.11b/g/n Wireless LAN+NFC Module

DESCRIPTION

RTL8711AM WiFi Module is a small form factor, single stream, 801.11 b/g/n WiFi module with embedded low power application processor. The module has been optimized for client applications in the home, enterprise, smart grid, home automation and control that have lower data rates and transmit or receive data on an infrequent basis.

The Module integrates all WiFi functionality into a low-profile, 19mm x 22.25mm SMT module package that can be easily mounted on a low-cost main PCB with application specific circuits.

apm supports a development platform that reduces development time through multiple interfaces and power supply options. The module includes an integrated antenna, variants for connecting external antenna consist of U.fl. The module offers a flexible interface includes SPI, I2C, I2S, PWM, PCM, UART, and ADC ports.

The Module combines an ARM-Cortex M3 MCU, WLAN MAC, a 1T1R capable WLAN baseband, and RF in the board. It also provides a configurable GPIOs which are configured as digital peripherals for different applications and control usage.

GENERAL FEATURES

- Small footprint: 19×22.25×2.3 mm max
- IEEE 802.11b/g/n compliant
- DSSS with DBSP and DQPSK, CCK modulation with long and short preamble.
- OFDM with BPSK, QPSK, 16QAM and 64QAM modulation.
- Embedded application processor with flexible interfaces.
- Available antenna variants : integrated PCB antenna,

I-PEX connector.

- Wide range of connector ports including GPIO ports, UART, I2C, SPI, I2S, PCM, PWM, ADC.
- Maximum 19 GPIO pins
- Integrated 2MB flash
- RoHS compliant

FEATURES

- One Transmit and one Receive path (1T1R)
- Support for IEEE 802.11e QoS(WMM)
- Support for IEEE 802.11i advanced security (WPA, WPA2)
- WiFi WPS support
- Light Weight TCP/IP protocol
- Power saving mechanism
- Support NFC Tag function

APPLICATIONS

- Sensors and multi-input sensors
- Building automation
- Home automation / Home Security
- Portable Unit

CERTIFICATE

- CE, FCC, Canada, CB, Japan Telec, Korea KCC, Taiwan NCC, AU/NZ Certified

APPEARANCE

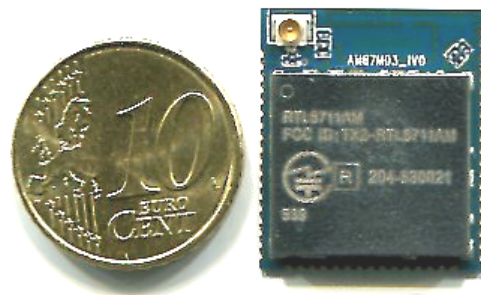

REVISION HISTORY

Date	Release	Author	Description
2015/6/23	0.1	Pol	Initial release
2015/7/16	0.2	Pol	Update current consumption in section 1-5 and recommended footprint in section 4-1
2015/10/14	0.3	Pol	Update module name Update package outline in section 3-1 and certification in section 6
2016/3/30	1.0	Pol	Update RF specification in section 1-4-2 Update operating temperature in section 1-3-2

TABLE OF CONTENTS

1	HARDWARE SPECIFICATION	5
1-1	BLOCK DIAGRAM	5
1-2	PINOUT	6
1-2-1	PIN ASSIGNMENT	6
1-2-2	PIN DESCRIPTION	6
1-2-3	PIN CONFIGURABLE FUNCTION GROUP SUMMARY TABLE	9
1-3	ELECTRICAL SPECIFICATION	9
1-3-1	ABSOLUTE MAXIMUM RATING	9
1-3-2	RECOMMENDED OPERATING CONDITIONS	10
1-4	RF SPECIFICATION 802.11B/G/N	10
1-4-1	OPERATING FREQUENCY	10
1-4-2	TRANSMITTER AND RECEIVER RF SPECIFICATION	10
1-5	CURRENT CONSUMPTION	12
2	FUNCTIONAL DESCRIPTION	13
2-1	POWER MODE DESCRIPTION	13
2-1-1	DEEP SLEEP MODE	13
2-1-2	DEEP STANDBY MODE	13
2-1-3	SLEEP MODE	14
2-1-4	SHUTDOWN MODE	14
2-2	GPIO FUNCTION	15
2-2-1	FEATURES OF GPIO	15
2-3	UART INTERFACE CHARACTERISTICS	15
2-3-1	FEATURES OF UART	15
2-3-2	HIGH SPEED UART SPECIFICATION	15
2-3-3	UART INTERFACE SIGNAL LEVELS	16
2-4	SPI INTERFACE	16
2-4-1	FEATURES OF SPI	16
2-5	I2C INTERFACE	17
2-5-1	FEARTURES OF I2C	17
2-6	PWM INTERFACE	17
2-6-1	FEATURES OF PWM	17
2-7	I2S INTERFACE CHARACTERISTICS	18
2-7-1	FEATURES OF I2S	18

2-8	PCM INTERFACE CHARACTERISTICS.....	18
2-8-1	FEATURES OF PCM.....	18
2-9	AD CONVERTER.....	19
2-9-1	FEATURES.....	19
3	MECHANICAL SPECIFICATION.....	20
3-1	PACKAGE OUTLINE.....	20
4	ASSEMBLY GUIDELINE.....	21
4-1	RECOMMENDED MOUNTING PAD DESIGN (TOP VIEW).....	21
4-2	BAKING CONDITION RECOMMENDATION BEFORE IR REFLOW.....	22
4-3	RECOMMENDATION FOR REFLOW PROFILE.....	22
5	QUALIFIED ANTENNA TYPES FOR RTL8711AM.....	23
6	CERTIFICATIONS.....	23
6-1	FCC.....	23
6-2	IC.....	24
6-3	CE.....	25
6-4	TELEC JAPAN.....	25
6-5	NCC TAIWAN.....	25
6-6	KCC KOREA.....	26

1 Hardware Specification

1-1 Block Diagram

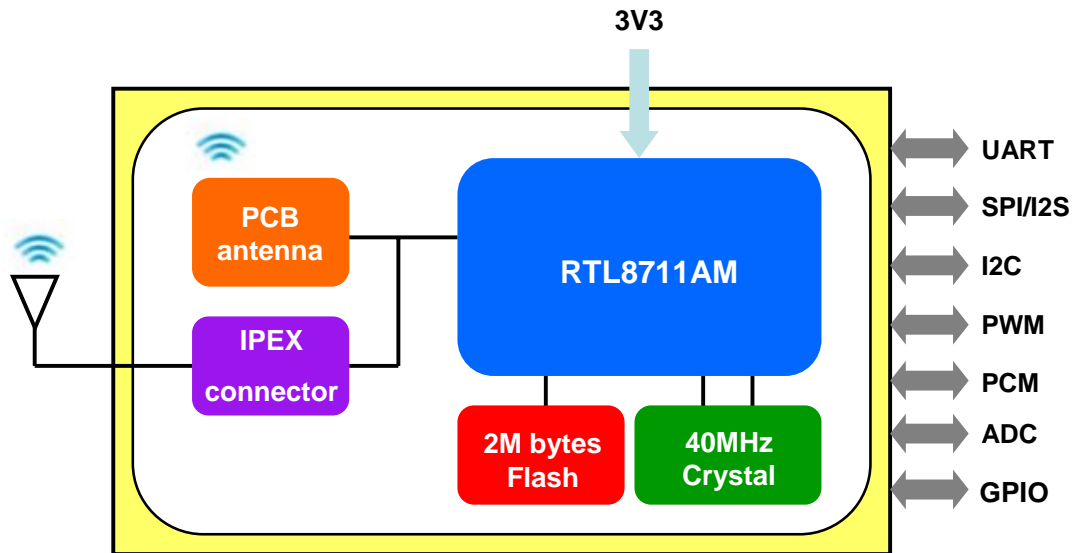

Product list :

Product code	
RTL8711AM	I-PEX connector
RTL8711AM-P	On-board PCB Antenna

1-2 Pinout

1-2-1 Pin Assignment

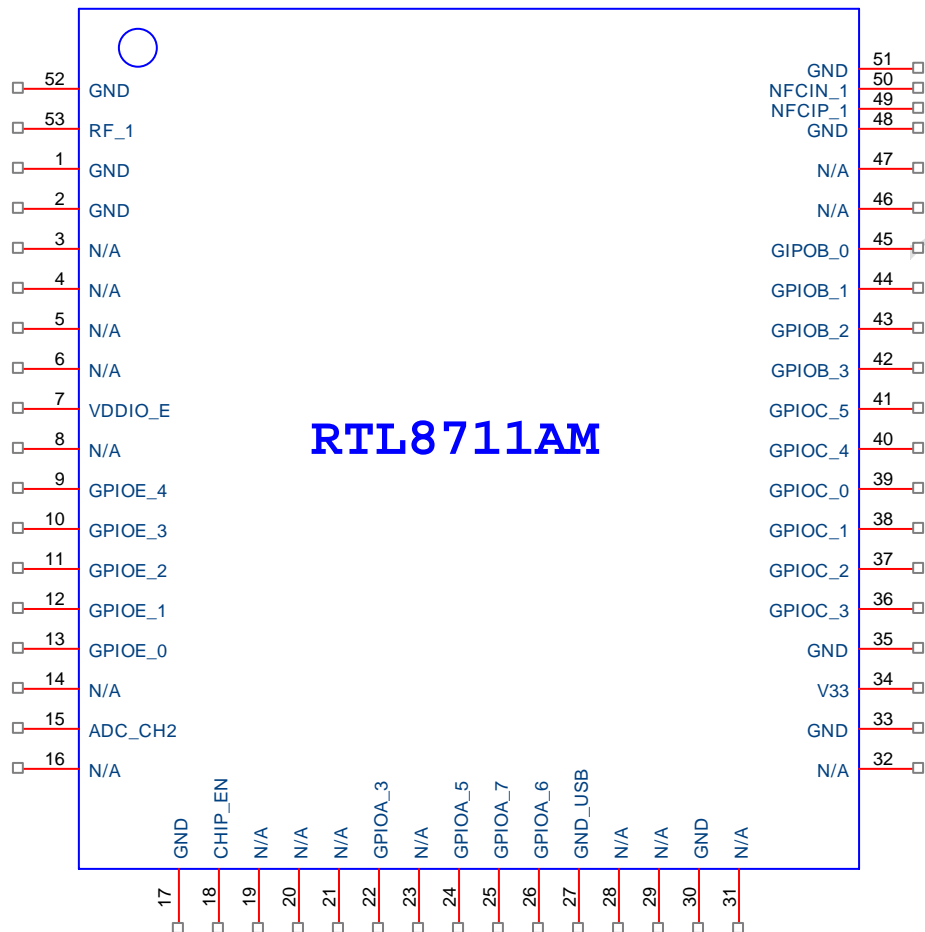

1-2-2 Pin Description

* I/O: Input/Output, I: Input, O: Output, A: Analog, P: Power, G: GND

#	Name	I/O	Description
1	GND	G	Module ground
2	GND	G	Module ground
3	N/A	-	Do not connect
4	N/A	-	Do not connect

#	Name	I/O	Description
5	N/A	-	Do not connect
6	N/A	-	Do not connect
7	VDDIO_E	P	GPIOE and GPIOC group IO power Power supply for +3V3
8	N/A	-	Do not connect
9	GPIOE_4	I/O	GPIO pin
10	GPIOE_3	I/O	GPIO pin
11	GPIOE_2	I/O	GPIO pin
12	GPIOE_1	I/O	GPIO pin
13	GPIOE_0	I/O	GPIO pin
14	N/A	-	Do not connect
15	ADC_CH2	A	AD converter input
16	N/A	-	Do not connect
17	GND	G	Module ground
18	CHIP_EN	I	1 : enable chip 0 : disable chip in shutdown mode
19	N/A	-	Do not connect
20	N/A	-	Do not connect
21	N/A	-	Do not connect
22	GPIOA_3	I/O	GPIO pin
23	N/A	-	Do not connect
24	GPIOA_5	I/O	GPIO pin
25	GPIOA_7	I/O	GPIO pin
26	GPIOA_6	I/O	GPIO pin
27	GND	G	Module ground
28	N/A	-	Do not connect
29	N/A	-	Do not connect
30	GND	G	Module ground
31	N/A	-	Do not connect
32	N/A	-	Do not connect
33	GND	G	Module ground
34	VD33	P	Power supply for +3V3
35	GND	G	Module ground

#	Name	I/O	Description
36	GPIOC_3	I/O	GPIO pin
37	GPIOC_2	I/O	GPIO pin
38	GPIOC_1	I/O	GPIO pin
39	GPIOC_0	I/O	GPIO pin
40	GPIOC_4	I/O	GPIO pin
41	GPIOC_5	I/O	GPIO pin
42	GPIOB_3	I/O	GPIO pin
43	GPIOB_2	I/O	GPIO pin
44	GPIOB_1	I/O	GPIO pin
45	GPIOB_0	I/O	GPIO pin
46	N/A	-	Do not connect
47	N/A	-	Do not connect
48	GND	G	Module ground
49	NFC_IP	I	NFC input differential signal
50	NFC_IN	I	NFC input differential signal
51	GND	G	Module ground
52	GND	G	Module ground
53	RF_1	A	RF input/output

1-2-3 Pin Configurable Function Group Summary Table

Pin Name	JTAG	UART Function	I2C Group	SPI Group	I2S Group	PCM Group	PWM Group
GPIOA_3		UART0_RTS					
GPIOA_5		UART0_CTS					
GPIOA_6		UART0_IN					
GPIOA_7		UART0_OUT					
GPIOB_0		UART_LOG_OUT					
GPIOB_1		UART_LOG_IN					
GPIOB_2			I2C3_SCL				
GPIOB_3			I2C3_SDA				
GPIOC_0		UART0_IN		SPI0_CS0	I2S1_WS	PCM1_SYNC	PWM0
GPIOC_1		UART0_CTS		SPI0_CLK	I2S1_CLK	PCM1_CLK	PWM1
GPIOC_2		UART0_RTS		SPI0_MOSI	I2S1_SD_TX	PCM1_OUT	PWM2
GPIOC_3		UART0_OUT		SPI0_MISO	I2S1_MCK	PCM1_IN	PWM3
GPIOC_4			I2C1_SDA	SPI0_CS1	I2S1_SD_RX		
GPIOC_5			I2C1_SCL	SPI0_CS2			
GPIOE_0	JTAG_TRST	UART0_OUT	I2C2_SCL	SPI0_CS0		PCM0_SYNC	PWM0
GPIOE_1	JTAG_TDI	UART0_RTS	I2C2_SDA	SPI0_CLK		PCM0_CLK	PWM1
GPIOE_2	JTAG_TDO	UART0_CTS	I2C3_SCL	SPI0_MOSI		PCM0_OUT	PWM2
GPIOE_3	JTAG_TMS	UART0_IN	I2C3_SDA	SPI0_MISO		PCM0_IN	PWM3
GPIOE_4	JTAG_CLK			SPI0_CS1			

1-3 Electrical Specification

1-3-1 Absolute Maximum Rating

Symbol	Description	Min.	Max.	Units
T _{ST}	Storage temperature	-40	+85	°C
VD33	Main supply voltage	-0.3	+3.6	V
VDDIO_E	GPIOE and GPIOC group IO power	-0.3	+3.6	V

1-3-2 Recommended Operating Conditions

Symbol	Description	Min.	Typ.	Max.	Units
T _{OP}	Operating temperature	-20	+25	+85	°C
VD33	Main supply voltage	+3.0	+3.3	+3.6	V
VDDIO_E	GPIOE and GPIOC group IO power	+1.7	+3.3	+3.6	V

1-4 RF Specification 802.11b/g/n

1-4-1 Operating frequency

Features	Description
Frequency band	2.400 GHz - 2.497 GHz
Number of channels	14 channels
Modulation	DSSS, OFDM, DBPSK, DQPSK, CCK, 16-QAM, 64-QAM
Supported rates	1, 2, 5.5, 11, 6, 9, 12, 24, 36, 48, 54, 65Mbps, 72.2Mbps, 135Mbps, 150Mbps

1-4-2 Transmitter and Receiver RF Specification

Conditions: VDD33=VDDIO_E=+3.3V, T_{OP}=+25°C

Parameter	Test conditions	Units	Min.	Typ.	Max.
802.11b Transmit					
Operating frequency range		-	Ch 1	-	Ch 13
Transmit output power	1/2/5.5/11Mbps	dBm	-	+17	-
Frequency error		ppm	-20	-2	+20
Transmit EVM	11Mbps, Channel 1~13	%	-	8	35
ACPR: 1 st side lobe power	Pout=+17.0dBm, 1/2/5.5/11Mbps	dBc	-	-42	-30
ACPR: 2 nd side lobe power	Pout=+17.0dBm, 1/2/5.5/11Mbps	dBc	-	-61	-50
Transmit ramp-up time	10% ~ 90%	μs	-	0.1	2
Transmit ramp-down time	90% ~ 10%	μs	-	0.4	2
802.11b Receive					

Parameter	Test conditions	Units	Min.	Typ.	Max.
Receive minimum input level sensitivity	11Mbps CCK, FER<8% at PSDU length of 1024 bytes	dBm	-	-86	-84
Receive maximum input level capability	11Mbps CCK, FER<8% at PSDU length of 1024 bytes	dBm	-20	-1	-
802.11g Transmit					
Operating frequency range		-	Ch 1	-	Ch 13
Transmit output power	54Mbps OFDM	dBm	-	+15	-
Frequency error	54Mbps OFDM	ppm	-20	+1.4	+20
Symbol clock freq. tolerance	54Mbps OFDM	ppm	-	+2.1	-
Transmit EVM	54Mbps OFDM, Channel 1~13	dB	-	-29	-25
Spectrum Mask	$f < fc-30, fc+30 < f$	dBr	-	-55	-40
	$fc-30 < f < fc-20, fc+20 < f < fc+30$		-	-47	-28
	$fc-20 < f < fc-11, fc+11 < f < fc+20$		-	-29	-20
	$fc-11 < f < fc-9, fc+9 < f < fc+11$		-	-16	-
Transmit ramp-up time	10% ~ 90%		-	0.1	2
Transmit ramp-down time	90% ~ 10%	μs	-	0.2	2
802.11g Receive					
Receive minimum input level sensitivity	54Mbps OFDM, FER<10% at PSDU length of 1024 bytes	dBm	-	-74	-72
Receive maximum input level capability	54Mbps OFDM, FER<10% at PSDU length of 1024 bytes	dBm	-20	-1	-
802.11n 20MHz Transmit					
Operating frequency range		-	Ch 1	-	Ch 13
Transmit output power	MCS7	dBm	-	+14	-
Transmit modulation accuracy	MCS7	dB	-	-30	-28
Frequency error	MCS7	ppm	-20	+2.1	+20
Symbol clock freq. tolerance	MSC7	ppm	-	+1.8	-
Spectrum Mask	$f < fc-30, fc+30 < f$	dBr	-	-54	-40
	$fc-30 < f < fc-20, fc+20 < f < fc+30$	dBr	-	-46	-28
	$fc-20 < f < fc-11, fc+11 < f < fc+20$	dBr	-	-27	-20
	$fc-11 < f < fc-9, fc+9 < f < fc+11$	dBr	-	-11	-
802.11n 20MHz Receive					

Parameter	Test conditions	Units	Min.	Typ.	Max.
Receive minimum input level sensitivity	MCS7 (FER<10% at PSDU length of 1024 bytes)	dBm	-	-71	-68
Receive maximum input level capability	MSC7 (FER<10% at PSDU length of 1024 bytes)	dBm	-20	-1	-
802.11n 40MHz Transmit					
Operating frequency range		-	Ch 1	-	Ch 13
Transmit output power	MCS7	dBm	-	+14	-
Transmit modulation accuracy	MCS7	dB	-	-30	-28
Frequency error	MCS7	ppm	-20	+2.5	+20
Symbol clock freq. tolerance	MSC7	ppm	-	+2.2	-
802.11n 40MHz Receive					
Receive minimum input level sensitivity	MCS7 (FER<10% at PSDU length of 1024 bytes)	dBm	-	-68	-66
Receive maximum input level capability	MSC7 (FER<10% at PSDU length of 1024 bytes)	dBm	-20	-1	-

1-5 Current Consumption

Mode	Current Consumption	Description
Deep Sleep	15 uA	Low power timer and 1 GPIO event wakeup
Deep Standby	43 uA	Low power timer and 4 GPIO event wakeup
Sleep	7.0 mA	System is not required to restart after wakeup
Run in Active clock	31 mA	CPU clock 166MHz, UART/SPI/I2C available WiFi is disable
11n RX Mode	70 mA	CPU clock 166MHz, UART/SPI/I2C available WiFi is in RX
11n TX Mode	227 mA	CPU clock 166MHz, UART/SPI/I2C available WiFi is in continual TX state

2 Functional Description

2-1 Power Mode Description

RTL8711AM supports three low power modes which are deep sleep mode, deep standby mode, and sleep mode. Deep sleep mode turn off more power domain than deep standby mode, and deep standby mode turn off more power domain than sleep mode.

2-1-1 Deep Sleep Mode

- **Power Domain** : Deep sleep mode turn off power domain including cortex-M3 core, system clock, SRAM, SDRAM and regulator. Peripherals are turned off except wakeup source which serve one wake-up pin and one low precision timer to wake up system. All of the registers are turned off except the ones that are used to kept wake-up pin. System restarts after wakeup.
- **Wakeup Sources** : It can be wake up by GPIOB_1 and general purpose timer. Each wakeup sources can be OR'ed, that means, either one condition fire up triggers wakeup event. (Ex. Both GPIOB_1 and lower precision timer can wakeup device).

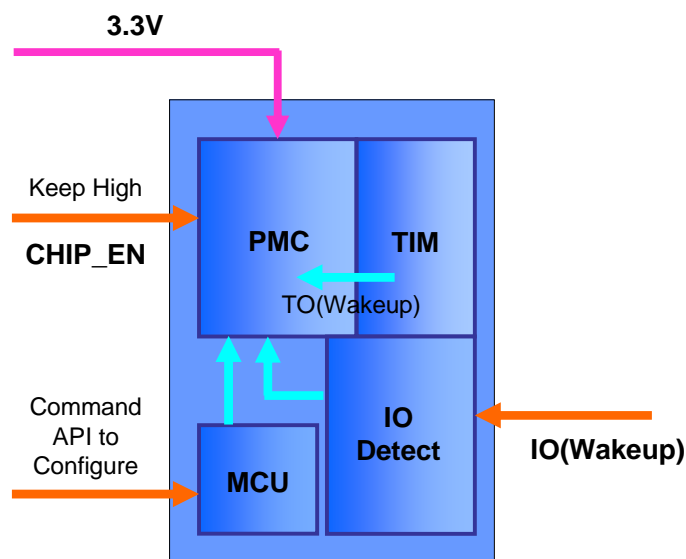

2-1-2 Deep Standby Mode

- **Power Domain** : Deep standby mode turn off power domain including cortex-M3 core, system clock, SRAM, SDRAM and regulator. Peripherals are turned off except wakeup source which serve 4 GPIO and one timer to wake up system. Only around 200 bytes of registers are kept for wakeup usage, other registers are turned off. System restarts

after wakeup.

- **Wakeup Sources** : It can be wake up by GPIOA_5, GPIOC_7, GPIOD_5, GPIOE_3 and system timer. Each wakeup sources can be OR'ed, that means, either one condition fire up triggers wakeup event.

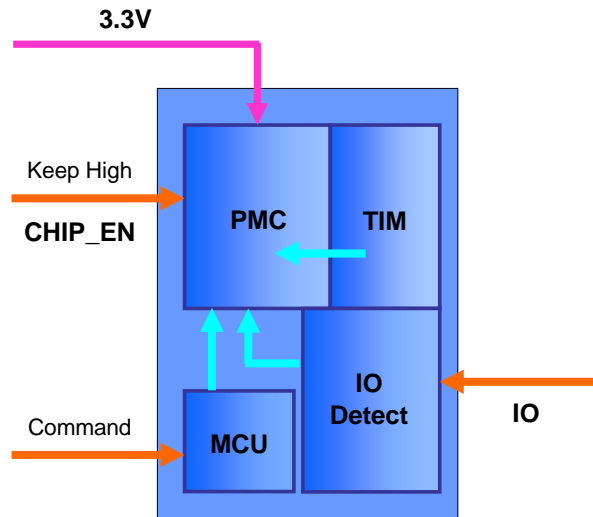

2-1-3 Sleep Mode

- **Power Domain** : Sleep mode turn off power domain including cortex-M3 core and system clock. System is not required to restart after wakeup.
- **Wakeup Sources** : It can be wakeup by GPIO interrupt, system timer and general purpose timer.

2-1-4 Shutdown Mode

CHIP_EN de-asserts to shutdown whole chip without external power cut components required.

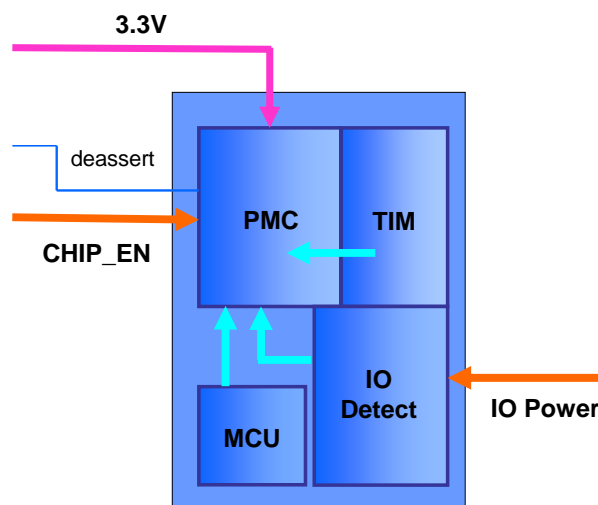

2-2 GPIO Function

2-2-1 Features of GPIO

- GPO and GPI function
- Support interrupt detection with configurable polarity per GPIO
- Internal weak pull up and pull low per GPIO
- Multiplexed with other specific digital functions

2-3 UART Interface Characteristics

2-3-1 Features of UART

- Support maximum 1 HS-UARTs (max baud rate 4MHz and DMA mode) or 1 low speed UARTs (IO mode)
- UART (RS232 Standard) serial data format
- Transmit and receive data FIFO
- Programmable asynchronous clock support
- Auto flow control
- Programmable receive data FIFO trigger level
- DMA data moving support to save CPU loading

The RTL8711AM UART interface is a standard 4-wire interface with RX, TX,CTS and RTS. The default baud rate is 115.2k baud. In order to support high and low speed baud rate, the RTL8711AM provides multiple UART clocks.

Desired Baud Rate	Actual Baud Rate	Error(%)	Desired Baud Rate	Actual Baud Rate	Error(%)
300	300	0.00%	153600	153061	-0.35%
600	600	0.00%	230400	229167	-0.54%
900	900	0.00%	460800	458333	-0.54%

1200	1200	0.00%	500000	500000	0.00%
1800	1800	0.00%	921600	916667	-0.54%
2400	2400	0.00%	1000000	1000000	0.00%
3600	3601	0.03%	1382400	1375000	-0.54%
4800	4798	-0.04%	1444444	1437500	-0.48%
7200	7198	-0.03%	1500000	1500000	0.00%
9600	9603	0.03%	1843200	1833333	-0.54%
14400	14395	-0.03%	2000000	2000000	0.00%
19200	19182	-0.09%	2100000	2083333	-0.79%
28800	28846	0.16%	2764800	2777778	0.47%
38400	38462	0.16%	3000000	3000000	0.00%
56000	55970	-0.05%	3250000	3250000	0.00%
57600	57692	0.16%	3692300	3703704	0.31%
76800	76531	-0.35%	3750000	3750000	0.00%
115200	115385	0.16%	4000000	4000000	0.00%
128000	127119	-0.69%			

2-3-3 UART Interface Signal Levels

The UART signal level ranges from 1.8V to 3.3V. The host provides the power source with the targeted power level to the RTL8711AM UART interface via the IO power.

2-4 SPI Interface

2-4-1 Features of SPI

- Support 1 SPI port
- Support Master/Slave mode
- Support DMA to offload CPU bandwidth
- 1 high speed SPI
 - Support up to 3 CS (multi-slave mode up to 3 slave)
 - Support baud rate up to 20MHz (Master mode)
 - Support baud rate up to 5MHz (Slave mode Rx only)

- Support baud rate up to 4MHz (Slave mode TRx)
- Programmable clock bit-rate
- Programmable clock polarity and phase
- Multiple serial interface operations support
 - Motorola – SPI
 - Texas Instruments – SSI
 - National Semiconductor - Microwire

2-5 I2C Interface

2-5-1 Features of I2C

- Support maximum 3 I2C port
- Three speeds:
 - Standard mode (0 to 100Kb/s)
 - Fast mode (<400Kb/s)
 - High-speed mode (<3.4Mb/s) (with appropriate bus loading)
- Master or slave I2C operation
- 7- or 10-bit addressing
- Transmit and receive buffers
- TX and RX DMA support (I2C-1 only)

2-6 PWM Interface

2-6-1 Features of PWM

- Support maximum 4 PWM functions

- 0~100% duty can be configurable
- Minimum resolution is 32us
- The period can be configured up to 8 seconds

2-7 I2S Interface Characteristics

2-7-1 Features of I2S

- Support 8/16/24/32/48/96KHz, 44.1/88.2KHz
- Support 16 or 24 bits format
- Integrated DMA engine to minimize SW efforts
- Support TX and RX direction
- Master or Slave mode support

2-8 PCM Interface Characteristics

2-8-1 Features of PCM

The RTL8711AM supports a PCM digital audio interface that is used for transmitting digital audio/voice data to/from the audio codec. Features are supported as below :

- Support Master and Slave mode
- Programmable long/short frame sync
- Support 8-bit A-law/ μ -law, and 13/16-bit linear PCM formats
- Support sign-extension and zero-padding for 8-bit and 13-bit samples
- Support padding of audio gain to 13-bit samples
- PCM master clock output : 64, 128, 256 or 512kHz
- Support SCO/ESCO link

2-9 AD Converter

2-9-1 Features

- 1 16-bit high resolution A/D converter (ADC_CH2 only)
 - Bandwidth 48kHz
 - Input signal range: 0.01V~VREF-0.2V
- Support DMA mode
- Support One-Shot sampling mode without CPU active to save power
 - Pre-configured period to auto-sampling
 - Support two wakeup method: buffer threshold interrupt and event trigger

3 Mechanical Specification

Dimension	19×22.25×2.3 mm (max. height)
Pinout	53
Weight	1.4267g
Antenna Option	External: I-PEX connector Internal: On-board PCB Antenna

3-1 Package Outline

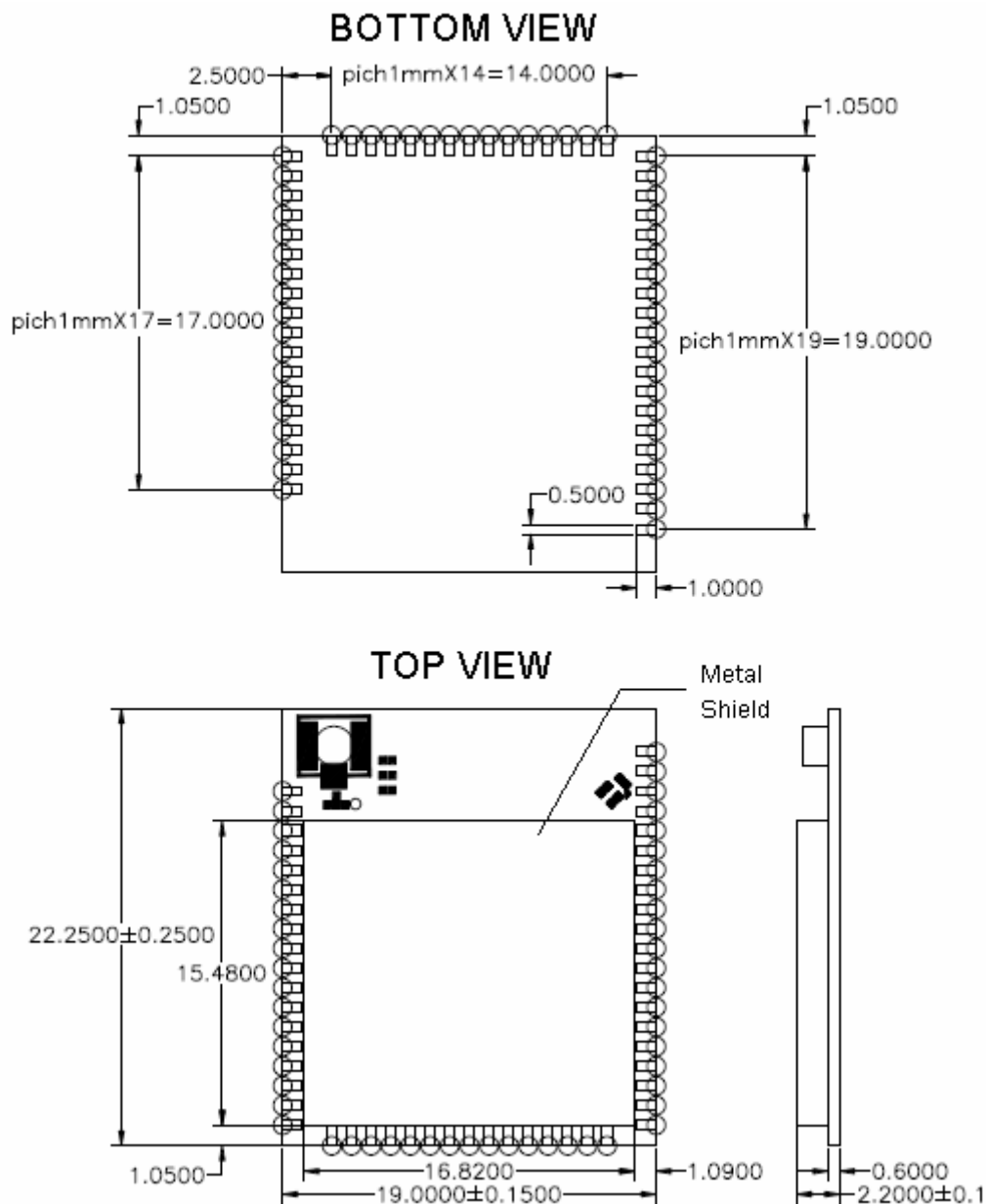

4 Assembly Guideline

4-1 Recommended Mounting Pad Design (Top View)

The following figure illustrates the recommended mounting pad design for RTL8711AM.

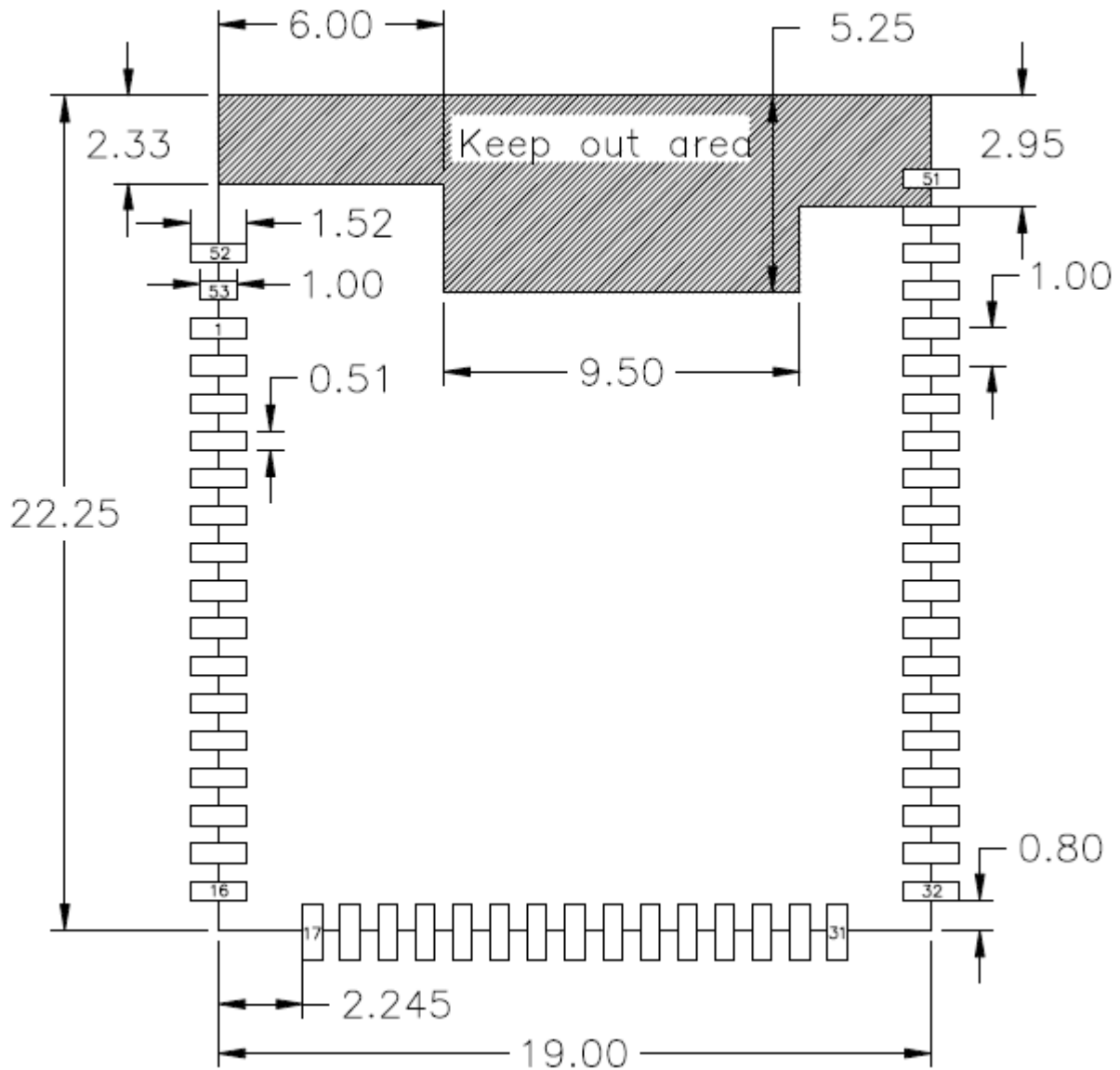

Physical dimension in mm

4-2 Baking condition recommendation before IR reflow

Baking condition for RTL8711AM module:

- I: 125°C/4hrs baking is necessary for RTL8711AM module before SMT process. After baking treatment the modules can be stored in the environment under 30°C and 60% RH for 48 hrs. If the storage time is over 48hrs, the modules need to be re-baked using the same condition again.
- II: In the event that the sealed bag is damaged on receipt of the modules, the baking condition should be changed to 125°C/24 hrs.

4-3 Recommendation for Reflow Profile

The solder profile depends on various parameters necessitating a set up for each application. The data here is given only for guidance on solder re-flow.

Maximum reflow temperature is 250°C

Preheat ramp-up rate	125°C to 180°C 1 to 3°C/ sec.
Peak temperature	250°C, Max.
Temperature maintained above 217°C	30 ~ 90 sec.
Cooling ramp-down rate	<2~4°C/ sec.
Maximum number of reflow cycles	≤3

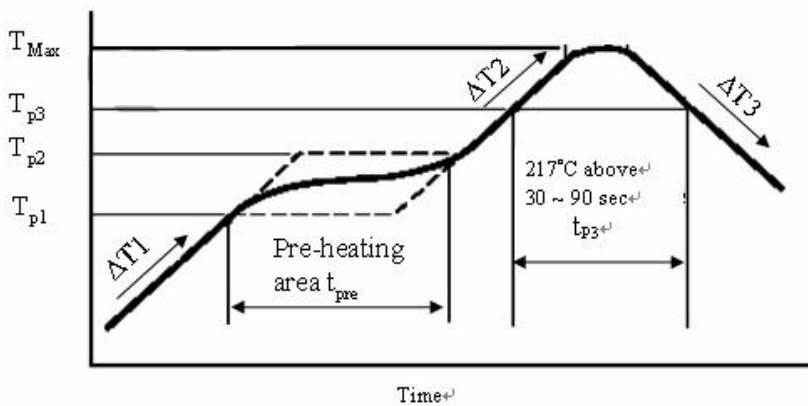

Typical Lead-Free Re-flow Solder Profile

Heating/Cooling Speed			Pre-Heating		Heating	
ΔT1	ΔT2	ΔT3	T _{p1} -T _{p2}	t _{pre}	T _{Max}	t _{p3}
1 to 3°C / sec	1 to 3°C / sec	< 2°C / sec	125 ~ 180°C	30 ~ 90 sec.	250°C max.	30 ~ 90 sec.

5 Qualified Antenna Types for RTL8711AM

RTL8711AM has been designed to operate with the antennas listed below, and having a maximum gain of 3.5 dBi. Antennas not included in this list or having a gain greater than 3.5dBi are strictly prohibited for use with this device. The required antenna impedance is 50 ohms.

Ant.	Brand	Model	Antenna Type	Gain (dBi)
1	apmcomm	N/A	Printed Antenna	2.0
2	LYNwave	ALA110-222050-300010	PIFA Antenna	3.5
3	JOYMAX	TWF	Dipole Antenna	3.0

Any antenna that is of the same type and of equal or less directional gain as listed in the table can be used without a need for retesting. To reduce potential radio interference to other user, apmcomm recommends using the same antenna type and gain should be lower 0.25 dBi than above table. Using an antenna of a different type or gain more than 3.5 dBi will require additional testing for FCC, CE and IC.

6 Certifications

RTL8711AM is compliant to the following specifications.

6-1 FCC

This device complies with Part 15 of the FCC Rules. Operation is subject to the following two conditions:

- (1) this device may not cause harmful interference, and
- (2) this device must accept any interference received, including interference that may cause undesired operation.

Any changes or modifications not expressly approved by apmcomm could void the user's authority to operate the equipment.

Radiation Exposure Statement :

This equipment complies with FCC radiation exposure limits set forth for an uncontrolled environment. This equipment should be installed and operated with minimum distance 20cm between the radiator & your body.

This transmitter must not be co-located or operating in conjunction with any other antenna or transmitter.

Country Code selection feature to be disabled for products marketed to the US/CANADA

This device is intended only for OEM integrators under the following conditions :

- (1) The antenna must be installed such that 20 cm is maintained between the antenna and users, and
- (2) The transmitter module may not be co-located with any other transmitter or antenna,

(3) For all products market in US, OEM has to limit the operation channels in CH1 to CH11 for 2.4G band by supplied software programming tool. OEM shall not supply any tool or info to the end-user regarding to Regulatory Domain change.

As long as 3 conditions above are met, further transmitter test will not be required. However, the OEM integrator is still responsible for testing their end-product for any additional compliance requirements required with this module installed.

IMPORTANT NOTE

In the event that these conditions cannot be met (for example certain laptop configurations or co-location with another transmitter), then the FCC authorization is no longer considered valid and the FCC ID cannot be used on the final product. In these circumstances, the OEM integrator will be responsible for re-evaluating the end product (including the transmitter) and obtaining a separate FCC authorization.

End Product Labeling

This transmitter module is authorized only for use in device where the antenna may be installed such that 20 cm may be maintained between the antenna and users. The final end product must be labeled in a visible area with the following:
“Contains FCC ID: TX2-RTL8711AM”

or

“Contains Transmitter Module FCC ID: TX2-RTL8711AM”

6-2 IC

This device complies with Industry Canada licence-exempt RSS standard(s). Operation is subject to the following two conditions:

- (1) this device may not cause interference, and
- (2) this device must accept any interference, including interference that may cause undesired operation of the device.

Radiation Exposure Statement :

This equipment complies with IC radiation exposure limits set forth for an uncontrolled environment. This equipment should be installed and operated with minimum distance 20cm between the radiator & your body.

This device is intended only for OEM integrators under the following conditions :

- (1) The antenna must be installed such that 20 cm is maintained between the antenna and users, and
- (2) The transmitter module may not be co-located with any other transmitter or antenna,

As long as 2 conditions above are met, further transmitter test will not be required. However, the OEM integrator is still responsible for testing their end-product for any additional compliance requirements required with this module installed.

IMPORTANT NOTE

In the event that these conditions cannot be met (for example certain laptop configurations or co-location with another transmitter), then the Canada authorization is no longer considered valid and the IC ID cannot be used on the final product. In these circumstances, the OEM integrator will be responsible for re-evaluating the end product (including the transmitter) and obtaining a separate Canada authorization.

End Product Labeling

This transmitter module is authorized only for use in device where the antenna may be installed such that 20 cm may be maintained between the antenna and users. The final end product must be labeled in a visible area with the following:
“Contains IC: 6317A-RTL8711AM”.

6-3 CE

RTL8711AM is in conformity with the essential requirements and other relevant requirements of the R&TTE Directive (1999/5/EC). The product is conformity with the following standards and/or normative documents.

EMC (immunity only) EN 301 489-17 V2.2.1 in accordance with EN 301 489-1 V1.9.2

Radiated emissions EN 300 328 V1.9.1

6-4 Telec Japan

RTL8711AM is certified as a module with type certification number 204-530021. When the holder of this certificate is placing the product on the Japanese market, the product must be affixed with the following Specified Radio Equipment marking:



6-5 NCC Taiwan

NCC Logo&ID :

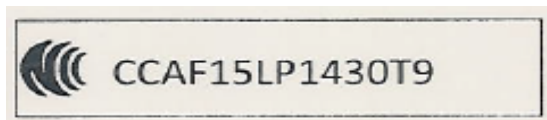

說明:

1. 請依上列標籤式樣自製標籤，標貼或印鑄於器材本體明顯處，始得販賣或公開陳列。

2. 為確保標誌的完整性與再現性，應以適當(方格子)比例大小標貼或印鑄於設備本體適當位置上。使用時盡量不要小於 15mm。
3. 如本體太小無法標印，應標印於最小單位包裝上。

6-6 KCC Korea

RTL8711AM has type certification in Korea with certification number MSIP-CRM-RTK-RTL8711AM.

KCC Logo&ID:



MSIP-CRM-RTK-RTL8711AM