

# REALTEK

## RTL8723CS

**SINGLE-CHIP 802.11b/g/n 1T1R WLAN, BLUETOOTH  
2.1/3.0/4.0/4.1 with SDIO INTERFACE, and HS-UART  
MIXED INTERFACE**

### **DATASHEET**

**(CONFIDENTIAL: Development Partners Only)**

**Rev. 0.1  
15 June, 2015  
Track ID:**



**Realtek Semiconductor Corp.**

No. 2, Innovation Road II, Hsinchu Science Park, Hsinchu 300, Taiwan

Tel.: +886-3-578-0211. Fax: +886-3-577-6047

[www.realtek.com](http://www.realtek.com)

**COPYRIGHT**

© 2012 Realtek Semiconductor Corp. All rights reserved. No part of this document may be reproduced, transmitted, transcribed, stored in a retrieval system, or translated into any language in any form or by any means without the written permission of Realtek Semiconductor Corp.

**DISCLAIMER**

Realtek provides this document 'as is', without warranty of any kind. Realtek may make improvements and/or changes in this document or in the product described in this document at any time. This document could include technical inaccuracies or typographical errors.

**TRADEMARKS**

Realtek is a trademark of Realtek Semiconductor Corporation. Other names mentioned in this document are trademarks/registered trademarks of their respective owners.

**USING THIS DOCUMENT**

This document is intended for the software engineer's reference and provides detailed programming information.

Though every effort has been made to ensure that this document is current and accurate, more information may have become available subsequent to the production of this guide.

**REVISION HISTORY**

Revision	Release Date	Summary
0.1	2015/6/15	Preliminary release.

## Table of Contents

<b>1. GENERAL DESCRIPTION</b> .....	<b>1</b>
<b>2. FEATURES</b> .....	<b>3</b>
<b>3. APPLICATION DIAGRAM</b> .....	<b>5</b>
3.1. INTEGRATED SINGLE-BAND 11N (1X1) CONTROLLER AND BLUETOOTH CONTROLLER WITH WL/BT SHARED ANTENNA	5
<b>4. PIN ASSIGNMENTS</b> .....	<b>6</b>
4.1. PACKAGE IDENTIFICATION .....	6
<b>5. PIN DESCRIPTIONS</b> .....	<b>6</b>
5.1. POWER-ON TRAP PINS .....	7
5.2. SDIO INTERFACE .....	7
5.3. GSPI INTERFACE.....	7
5.4. HS-UART TRANSCEIVER INTERFACE .....	7
5.5. LOG UART TRANSCEIVER INTERFACE.....	8
5.6. PCM INTERFACE .....	8
5.7. I <sup>2</sup> S INTERFACE .....	8
5.8. BT 3D DISPLAY INTERFACE.....	9
5.9. RF INTERFACE .....	9
5.10. LED INTERFACE.....	9
5.11. POWER MANAGEMENT HANDSHAKE INTERFACE .....	10
5.12. CLOCK AND OTHER PINS .....	10
5.13. POWER PINS .....	11
<b>6. ELECTRICAL AND THERMAL CHARACTERISTICS</b> .....	<b>12</b>
6.1. TEMPERATURE LIMIT RATINGS .....	12
6.2. POWER SUPPLY DC CHARACTERISTICS .....	12
6.3. DIGITAL IO PIN DC CHARACTERISTICS .....	12
6.4. SDIO/GSPI INTERFACE AC CHARACTERISTICS .....	14
6.4.1. SDIO/GSPI Interface Signal Levels .....	15
6.4.2. SDIO Interface Power-On Sequence.....	15
6.4.3. GSPI Interface Power-On Sequence .....	16
6.5. UART INTERFACE CHARACTERISTICS.....	18
6.6. PCM INTERFACE CHARACTERISTICS .....	3
6.6.1. PCM Format.....	3
6.6.2. Sign Extension and Zero Padding for 8-Bit and 13-Bit Samples .....	4
6.6.3. PCM Interface Timing.....	5
6.6.4. PCM Interface Signal Levels.....	6
<b>7. MECHANICAL DIMENSIONS</b> .....	<b>7</b>
7.1. MECHANICAL DIMENSIONS NOTES.....	8
<b>8. ORDERING INFORMATION</b> .....	<b>9</b>
<b>9</b> .....	<b>9</b>

## List of Tables

TABLE 1. POWER ON TRAP PINS.....	7
TABLE 2. SDIO INTERFACE.....	7
TABLE 3. GSPI INTERFACE.....	7
TABLE 4. HS-UART INTERFACE.....	7
TABLE 5. LOG UART INTERFACE.....	8
TABLE 7. PCM INTERFACE.....	8
TABLE 8. PCM INTERFACE.....	8
TABLE 9. BT 3DD INTERFACE.....	9
TABLE 10. RF INTERFACE.....	9
TABLE 11. LED INTERFACE.....	9
TABLE 12. POWER MANAGEMENT HANDSHAKE INTERFACE.....	10
TABLE 13. CLOCK AND OTHER PINS.....	10
TABLE 14. POWER PINS.....	11
TABLE 16. TEMPERATURE LIMIT RATINGS.....	12
TABLE 17. POWER SUPPLY DC CHARACTERISTICS.....	12
TABLE 18. 3.3V IO DC CHARACTERISTICS.....	12
TABLE 19. 2.8V IO DC CHARACTERISTICS.....	12
TABLE 20. 1.8V IO DC CHARACTERISTICS.....	13
TABLE 22. SDIO INTERFACE POWER-ON SEQUENCE.....	15
TABLE 23. SDIO INTERFACE POWER-ON TIMING PARAMETERS.....	16
TABLE 24. GSPI INTERFACE POWER-ON SEQUENCE.....	16
TABLE 25. SPI INTERFACE POWER-ON TIMING PARAMETERS.....	17
TABLE 26. UART INTERFACE POWER-ON TIMING PARAMETERS.....	18
TABLE 27. UART INTERFACE POWER-ON SEQUENCE PARAMETERS.....	1
TABLE 28. UART INTERFACE POWER-ON TIMING SPECIFICATIONS.....	2
TABLE 29. PCM INTERFACE CLOCK SPECIFICATIONS.....	6
TABLE 30. PCM INTERFACE TIMING.....	6
TABLE 31. ORDERING INFORMATION.....	9

---

## List of Figures

---

FIGURE 1. RTL8723CS WITH SHARED ANTENNA BETWEEN WLAN AND BLUETOOTH.....	5
FIGURE 2. PIN ASSIGNMENTS.....	6
FIGURE 6. SDIO INTERFACE POWER-ON SEQUENCE.....	15
FIGURE 7. GSPI INTERFACE POWER-ON SEQUENCE.....	16
FIGURE 6. UART INTERFACE WAVEFORM.....	1
FIGURE 7. UART POWER-ON SEQUENCE WITHOUT HARDWARE FLOW CONTROL.....	1
FIGURE 8. UART POWER-ON SEQUENCE WITH HARDWARE FLOW CONTROL.....	1
FIGURE 9. LONG FRAMESYNC.....	3
FIGURE 10. SHORT FRAMESYNC.....	3
FIGURE 11. 16-BIT OUTPUT DATA WITH 8-BIT PCM SAMPLE DATA AND SIGN EXTENSION.....	4
FIGURE 12. 16-BIT OUTPUT DATA WITH 8-BIT PCM SAMPLE DATA AND ZERO PADDING.....	4
FIGURE 13. 16-BIT OUTPUT DATA WITH 13-BIT PCM SAMPLE DATA AND SIGN EXTENSION.....	4
FIGURE 14. 16-BIT OUTPUT DATA WITH 13-BIT PCM SAMPLE DATA AND AUDIO GAIN.....	4
FIGURE 15. PCM INTERFACE (LONG FRAMESYNC).....	5
FIGURE 16. PCM INTERFACE (SHORT FRAMESYNC).....	5

---

# 1. General Description

The Realtek RTL8723CS is a highly integrated 802.11b/g/n 1T1R WLAN, an integrated Bluetooth 2.1/3.0/4.0/4.1 single chip. It combines a WLAN MAC, a 1T1R capable WLAN baseband, BT Protocol Stack (LM, LL, and LE), BT Baseband, modem, and WLAN/BT RF in a single chip. The RTL8723CS provides a complete solution for a high throughput performance integrated wireless LAN, and Bluetooth controller.

The RTL8723CS WLAN baseband implements Orthogonal Frequency Division Multiplexing (OFDM) with 1 transmit and 1 receive path and is compatible with the 802.11n specification. Features include one spatial stream transmission, short guard interval (GI) of 400ns, spatial spreading, and transmission over 20MHz and 40MHz bandwidth.

For legacy compatibility, Direct Sequence Spread Spectrum (DSSS), Complementary Code Keying (CCK) and OFDM baseband processing are included to support all 802.11b and 802.11g data rates. Differential phase shift keying modulation schemes, DBPSK and DQPSK with data scrambling capability, are available, and CCK provides support for legacy data rates, with long or short preamble. The high-speed FFT/IFFT paths, combined with BPSK, QPSK, 16QAM, and 64QAM modulation of the individual subcarriers and rate compatible punctured convolutional coding with coding rate of 1/2, 2/3, 3/4, and 5/6, provide higher data rates of 54Mbps and 150Mbps for 802.11g and 802.11n OFDM respectively.

A built-in enhanced signal detector, adaptive frequency domain equalizer, and a soft-decision Viterbi decoder help to alleviate multi-path effects and mutual interference in the reception of multiple streams. Robust interference detection and suppression are provided to protect against Bluetooth, cordless phone, and microwave oven interference.

Efficient IQ-imbalance, DC offset, phase noise, frequency offset, and timing offset compensations are provided for the radio frequency front-end. Selectable digital transmit and receive FIR filters are provided to meet transmit spectrum mask requirements and to reject adjacent channel interference, respectively.

The RTL8723CS WLAN Controller supports fast receiver Automatic Gain Control (AGC) with synchronous and asynchronous control loops among antennas, antenna diversity functions, and adaptive transmit power control function to obtain better performance in the analog portions of the transceiver.

The RTL8723CS WLAN MAC supports 802.11e for multimedia applications, 802.11i for security, and 802.11n for enhanced MAC protocol efficiency. Using packet aggregation techniques such as A-MPDU with BA and A-MSDU, protocol efficiency is significantly improved. Power saving mechanisms such as Legacy Power Save, and U-APSD, reduce the power wasted during idle time, and compensate for the extra power required to transmit OFDM. The RTL8723CS provides simple legacy and 20MHz/40MHz co-existence mechanisms to ensure backward and network compatibility.

The RTL8723CS Bluetooth controller complies with Bluetooth core specification v4.1, and supports dual mode (BR/EDR + AMP + Low Energy Controllers). It is compatible with previous versions, including v2.1 + EDR and v3.0. For BR/EDR, it supports scatternet topology and allows four active links in slave mode, and seven active links in master mode. For Low Energy, it supports multiple states and allows eight active links in master mode. The links in BR/EDR and LE can be active simultaneously.

## 2. Features

### General

- QFN40
- 802.11b/g/n 1T1R WLAN and Bluetooth single chip

### Host Interface

- Complies with SDIO 1.1/2.0 for WLAN with clock rate up to 50MHz (SDR25)
- GSPI interface for configurable endian for WLAN
- Complies with HS-UART with configurable baud rate for Bluetooth

### WLAN Controller

- CMOS MAC, Baseband PHY, and RF in a single chip for 802.11b/g/n compatible WLAN
- Complete 802.11n solution for 2.4GHz band
- 72.2Mbps receive PHY rate and 72.2Mbps transmit PHY rate using 20MHz bandwidth
- 150Mbps receive PHY rate and 150Mbps transmit PHY rate using 40MHz bandwidth
- Compatible with 802.11n specification
- Backward compatible with 802.11b/g devices while operating in 802.11n mode
- 802.11b/g/n compatible WLAN
- 802.11e QoS Enhancement (WMM)
- 802.11i (WPA, WPA2). Open, shared key, and pair-wise key authentication services

- WAPI Key management and HW encryption and decryption.

### WLAN MAC Features

- Frame aggregation for increased MAC efficiency (A-MSDU, A-MPDU)
- Low latency immediate High-Throughput Block Acknowledgement (HT-BA)
- PHY-level spoofing to enhance legacy compatibility
- Power saving mechanism
- Channel management and co-existence
- Transmit Opportunity (TXOP) Short Inter-Frame Space (SIFS) bursting for higher multimedia bandwidth
- Support WiFi FTM (Fine Time Measurement) for WiFi Location Applications

### WLAN PHY Features

- 802.11n OFDM
- One Transmit and one Receive path (1T1R)
- 20MHz and 40MHz bandwidth transmission
- Short Guard Interval (400ns)
- DSSS with DBPSK and DQPSK, CCK modulation with long and short preamble



- OFDM with BPSK, QPSK, 16QAM, and 64QAM modulation.  
Convolutional Coding Rate: 1/2, 2/3, 3/4, and 5/6
- Maximum data rate 54Mbps in 802.11g; and 150Mbps in 802.11n
- Switch diversity for DSSS/CCK
- Selectable receiver FIR filters
- Programmable scaling in transmitter and receiver to trade quantization noise against increased probability of clipping
- Fast receiver Automatic Gain Control (AGC)
- On-chip ADC and DAC

#### Bluetooth Controller

- Compatible with Bluetooth v2.1+EDR
- Supports Bluetooth 4.0/4.1 Low Energy(BLE)
- HS-UART interface for Bluetooth data transmission compliant with H4 and H5 specification
- PCM interface for audio data transmission via Bluetooth controller
- Integrated MCU to execute Bluetooth protocol stack
- Supports all packet types in basic rate and enhanced data rate
- Supports SCO/eSCO link (allows one link for PCM interface and three links for HS-UART)
- Supports 4 piconets in a scatternet

- Supports Secure Simple Pairing
- Supports Low Power Mode (Sniff/Sniff Sub-rating/Hold/Park)
- Enhanced BT/WIFI Coexistence Control to improve transmission quality in different profiles
- Bluetooth 4.0/4.1 Dual Mode support: Simultaneous LE and BR/EDR
- Supports multiple Low Energy states
- Support PLC (Packet Loss Compensation)

#### Bluetooth Transceiver

- Fast AGC control to improve receiving dynamic range
- Supports AFH to dynamically detect channel quality to improve transmission quality
- Integrated internal Class 1, Class 2, and Class 3 PA
- Supports Power Control/Enhanced Power Control
- Bluetooth Low Energy Support

#### Peripheral Interfaces

- General Purpose Input/Output (12 pins)
- One configurable LED pins shared by WL and BT

### 3. Application Diagram

#### 3.1. Integrated Single-Band 11n (1x1) Controller and Bluetooth Controller with WL/BT Shared antenna

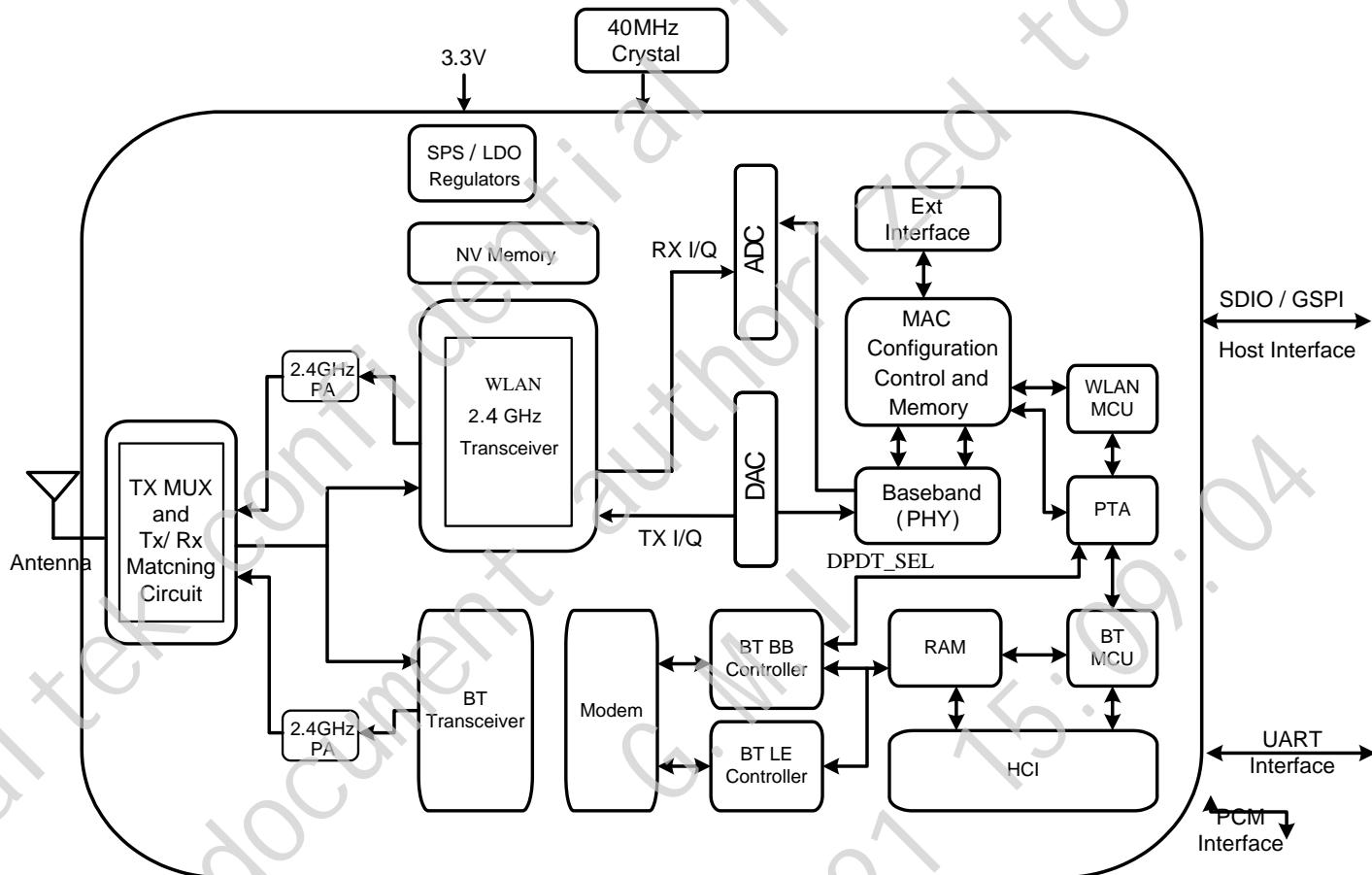


Figure 1. RTL8723CS with shared antenna between WLAN and Bluetooth

## 4. Pin Assignments

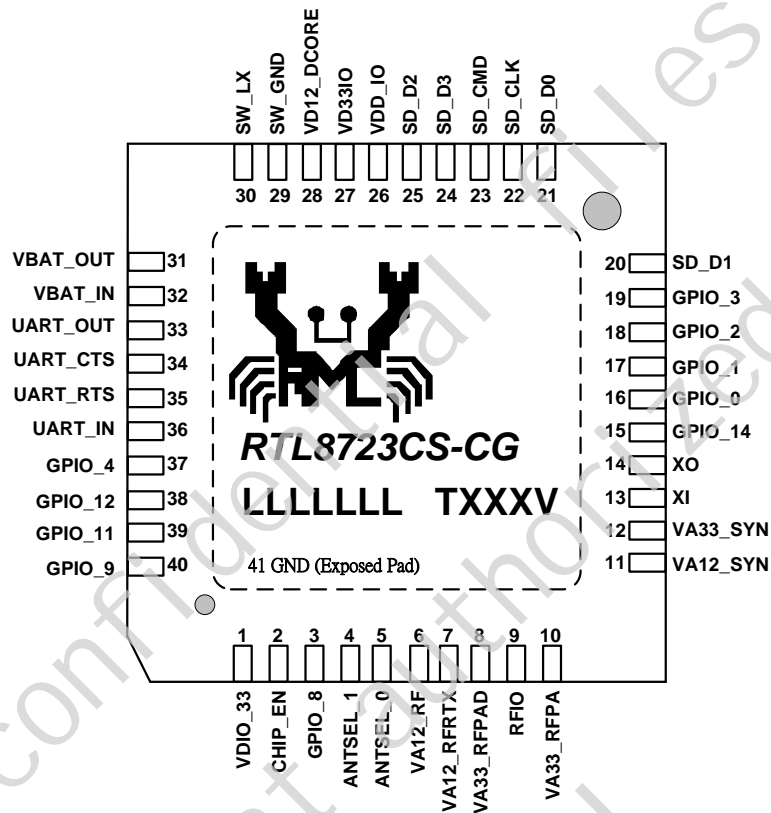


Figure 2. Pin Assignments

### 4.1. Package Identification

'Green' package is indicated by a 'G' in the location marked 'T' in Figure 2. The version is shown in the location marked 'V', e.g., Q=Version Q.

## 5. Pin Descriptions

The following signal type codes are used in the tables:

I: Input

O: Output

## 5.1. Power-On Trap Pins

**Table 1. Power On Trap Pins**

Symbol	Type	Pin No	Description
TEST_MODE_SEL	I	5	Shared with ANTSEL_0 0: Normal operation mode 1: Enter into test/debug mode
SPS_LDO_SEL	I	17	Shared with GPIO1 0: Internal switching regulator select 1: Internal LDO select
EEPROM_SEL	I	37	Shared with GPIO4 pin 0: Internal NV memory select 1: External EEPROM select

## 5.2. SDIO Interface

**Table 2. SDIO Interface**

Symbol	Type	Pin No	Description
SD_CLK	I	22	SDIO Clock Input
SD_CMD	IO	23	SDIO Command Input
SD_D0	IO	21	SDIO Data Line 0
SD_D1	IO	20	SDIO Data Line 1
SD_D2	IO	25	SDIO Data Line 2
SD_D3	IO	24	SDIO Data Line 3

Note: Refer to section 6.4.1, page 15 for SDIO signal level selection.

## 5.3. GSPI Interface

**Table 3. GSPI Interface**

Symbol	Type	Pin No	Description
GSPI_CLK	I	22	GSPI Clock Input
GSPI_DI	I	23	GSPI Data Input
GSPI_DO	O	21	GSPI Data Out
GSPI_INT	O	20	GSPI Interrupt
GSPI_CS <sub>n</sub>	I	25	GSPI Chip Select

Note 1: GSPI and SDIO are shared pins.

Note 2: Refer to section 6.4.1, page 15 for GSPI signal level selection.

## 5.4. HS-UART Transceiver Interface

**Table 4. HS-UART Interface**

Symbol	Type	Pin No	Description
UART_OUT	O	33	High-Speed UART Data Out

Symbol	Type	Pin No	Description
UART_CTS	I	34	High-Speed UART CTS
UART_RTS	O	35	High-Speed UART RTS
UART_IN	I	36	High-Speed UART Data In

Note: Refer to section [錯誤! 找不到參照來源。](#), page [錯誤! 尚未定義書籤。](#) for UART signal level selection.

## 5.5. Log UART Transceiver Interface

**Table 5. Log UART Interface**

Symbol	Type	Pin No	Description
BT_UART_OUT	O	5	Shared with ANTSEL_0. BT UART Data Out
BT_UART_IN	I	3	Shared with GPIO8. BT UART Data In
WL_UART_OUT	O	5	Shared with ANTSEL_0. WL UART Data Out
WL_UART_IN	I	4	Shared with ANTSEL_1. WL UART Data In

## 5.6. PCM Interface

**Table 6. PCM Interface**

Symbol	Type	Pin No	Description
PCM_IN	I	16	PCM data Input, shared with GPIO0
PCM_OUT	O	17	PCM data Out, shared with GPIO1
PCM_SYNC	O	18	PCM Synchronization control, shared with GPIO2
PCM_CLK	IO	19	PCM Clock, shared with GPIO3

## 5.7. I<sup>2</sup>S Interface

**Table 7. PCM Interface**

Symbol	Type	Pin No	Description
I2S_IN	I	16	I <sup>2</sup> S Input, shared with GPIO0
I2S_OUT	O	17	I <sup>2</sup> S Out, shared with GPIO1
I2S_WS	O	18	I <sup>2</sup> S Word Synchronization control, shared with GPIO2
I2S_CLK	IO	19	I <sup>2</sup> S Clock, shared with GPIO3

## 5.8. BT 3D Display Interface

**Table 8. BT 3DD Interface**

Symbol	Type	Pin No	Description
3DG_SYNC_A	I	38	Shared with GPIO12 BT 3D Glass Synchronization control port A.
3DG_SEL_A	I	37	Shared with GPIO4. BT 3D Glass Select control port A.

Note: Pin 38 and 37 refer to VDD\_IO (pin 26)

## 5.9. RF Interface

**Table 9. RF interface**

Symbol	Type	Pin No	Description
RFIO_G_S0	IO	9	WLAN/BT RF TX/RX signal port
ANTSEL_1	O	5	Antenna Select control Positive signal
ANTSEL_0	O	4	Antenna Select control Negative signal

Note: ANTSEL\_0 and ANTSEL\_1 refer to the IO level from pin 1 (VD33IO)

## 5.10. LED Interface

**Table 10. LED Interface**

Symbol	Type	Pin No	Description
LED0	O	3	LED Pin (Active Low). Shared with GPIO8

Note: These IO pins refer to the IO level from pin 1 (VD33IO)

## 5.11. Power Management Handshake Interface

**Table 11. Power Management Handshake Interface**

Symbol	Type	Pin No	Description
CHIP_EN	I	2	This Pin Can externally shut down the RTL8723CS- CG (No Extra Power Switch Required). When this function is not required, external pull high is required.
WL_DISn	I	40	Shared with GPIO9 This Pin Can Externally Shutdown the RTL8723CS-CG WLAN function when WL_DISn is Pulled Low. When this pin deasserted, SDIO interface will be disabled. This pin can also support the WLAN Radio-off function with host interface remaining connected. When BT_DISn is also deasserted, RTL8723CS-CG will enter the whole chip reset state.
BT_DISn	I	39	Shared with GPIO11. This Pin Can Externally Shutdown the RTL8723CS-CG BT function when BT_DISn is Pulled Low. This pin can also support the BT Radio-off function with host interface remaining connected. When BWL_DISn is also deasserted, RTL8723CS-CG will enter the whole chip reset state.
DEV_WAKE_HOST	O	15	Shared with GPIO14 This pin is shared with either WIFI or BT functions to wake up the host when the remote wake function is enabled. The polarity can be defined by the customer. This Wakeup pin can be configured as shared wakeup pin by both WL and BT when any of WL and BT function issue the wake signal to the host.
HOST_WAKE_DEV	I	38	Shared with GPIO12 This pin can be configured as the host wakes up the WLAN or Bluetooth controller or both of them in Remote Wakeup Mode.

Note: These IO pins refer to the IO level from pin 26 (VDD\_IO)

## 5.12. Clock and Other Pins

**Table 12. Clock and Other Pins**

Symbol	Type	Pin No	Description
XI	I	13	26M/40MHz OSC Input Input of 26M/40MHz Crystal Clock Reference
XO	O	14	Output of 26MHz/40MHz Crystal Clock Reference
SUS_CLK	I	35	Shared with GPIO6. External 32K or RTC clock input.
GPIO0	IO	16	General Purpose Input/Output Pin
GPIO1	IO	17	General Purpose Input/Output Pin
GPIO2	IO	18	General Purpose Input/Output Pin
GPIO3	IO	19	General Purpose Input/Output Pin
GPIO4	IO	37	General Purpose Input/Output Pin
GPIO8	IO	3	General Purpose Input/Output Pin
GPIO9	IO	40	General Purpose Input/Output Pin
GPIO11	IO	39	General Purpose Input/Output Pin

Symbol	Type	Pin No	Description
GPIO12	IO	38	General Purpose Input/Output Pin

Note: GPIO8 pins refer to VD33IO power level (pin 1), and all other pins refer to VDD\_IO power level (pin 26).

### 5.13. Power Pins

**Table 13. Power Pins**

Symbol	Type	Pin No	Description
SW_LX	P	30	Switching Regulator Output
VBAT_OUT	P	31	Switching Regulator Input (When VBAT LDO is not used) Or Linear Regulator input from 3.3V to 1.5V This pin is also the VBAT LDO output with 3.3V.
VBAT_IN	P	32	VBAT LDO input from 5V to 3.4V.
VA33_RFPAD, VA33_RFPA	P	8, 10, 12	3.3V for Analog Circuit
VD33IO	P	1, 27	VDD3.3V for Digital IO
VDD_IO	P	26	VDD digital IOs (3.3V~1.8V)
VD12_DCORE	P	28	VDD 1.2V Digital Circuit
VA12_RF, VA12_RFRTX, VA12_SYN	P	6, 7, 11	1.2V for analog blocks
SW_GND	P	29	Switching Regulator Ground



## 6. Electrical and Thermal Characteristics

### 6.1. Temperature Limit Ratings

**Table 14. Temperature Limit Ratings**

Parameter	Minimum	Maximum	Units
Storage Temperature	-55	+125	°C
Ambient Operating Temperature	0	70	°C
Junction Temperature	0	125	°C

### 6.2. Power Supply DC Characteristics

**Table 15. Power Supply DC Characteristics**

Symbol	Parameter	Minimum	Typical	Maximum	Units
VA33, VD33IO, VBAT_OUT,	3.3V Supply Voltage	3.0	3.3	3.6	V
VDD_IO	Digital IO Supply Voltage	1.62	1.8~3.3	3.6	V
VA12, VD12_DCORE	1.2V Core Supply Voltage	1.08	1.2	1.32	V
IDD33	3.3V Rating Current	-	-	450	mA

### 6.3. Digital IO Pin DC Characteristics

**Table 16. 3.3V IO DC Characteristics**

Symbol	Parameter	Minimum	Normal	Maximum	Units
V <sub>IH</sub>	Input high voltage	2.0	3.3	3.6	V
V <sub>IL</sub>	Input low voltage	-	0	0.9	V
V <sub>OH</sub>	Output high voltage	2.97	-	3.3	V
V <sub>OL</sub>	Output low voltage	0	-	0.33	V

**Table 17. 2.8V IO DC Characteristics**

Symbol	Parameter	Minimum	Normal	Maximum	Units
V <sub>IH</sub>	Input high voltage	1.8	2.8	3.1	V
V <sub>IL</sub>	Input low voltage	-	0	0.8	V
V <sub>OH</sub>	Output high voltage	2.5	-	3.1	V
V <sub>OL</sub>	Output low voltage	0	-	0.28	V

**Table 18. 1.8V IO DC Characteristics**

Symbol	Parameter	Minimum	Normal	Maximum	Units
V <sub>IH</sub>	Input high voltage	1.3	1.8	2.0	V
V <sub>IL</sub>	Input low voltage	-	0	0.8	V
V <sub>OH</sub>	Output high voltage	1.62	-	1.8	V
V <sub>OL</sub>	Output low voltage	0	-	0.18	V

#### **6.4. SDIO/GSPI Interface AC Characteristics**

For SDIO timing criteria, please refer to “SD specification Part I Physical Layer Specification version 3.01”.

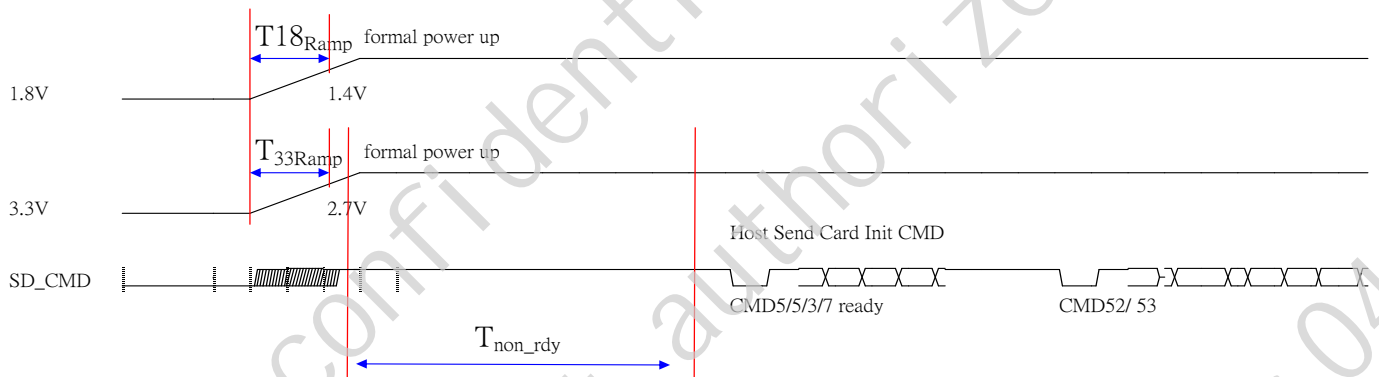
### 6.4.1. SDIO/GSPI Interface Signal Levels

The SDIO and GSPI signal level ranges from 1.8V to 3.3V. The host provides the power source with the target power level to the RTL8723CS-CG SDIO and GSPI interfaces via the VDD\_IO pin (Pin 26).

The 3.3V, 2.8V, and 1.8V DC characteristics of typical signal levels are shown in section 6.3 Digital IO Pin DC Characteristics, page 12.

### 6.4.2. SDIO Interface Power-On Sequence

After power-on, the SDIO interface is selected by the RTL8723BS-VC automatically when a valid SDIO command is received. To attain better SDIO host compatibility, the following power-on sequence is recommended.



**Figure 3. SDIO Interface Power-On Sequence**

**Table 19. SDIO Interface Power-On Sequence**

Symbol	Description
$T_{33\text{ramp}}$	The 3.3V main power ramp up duration.
$T_{18\text{ramp}}$	The 1.8V main power ramp up duration.
$T_{\text{non\_rdy}}$	SDIO Not Ready Duration. In this state, the RTL8723BS-VC may respond to commands without the ready bit being set. After the ready bit is set, the host will initiate complete card detection procedure.

We recommend that the card detection procedures are divided into two phases: A 3.3V power pre-charge phase and a formal power-up phase.

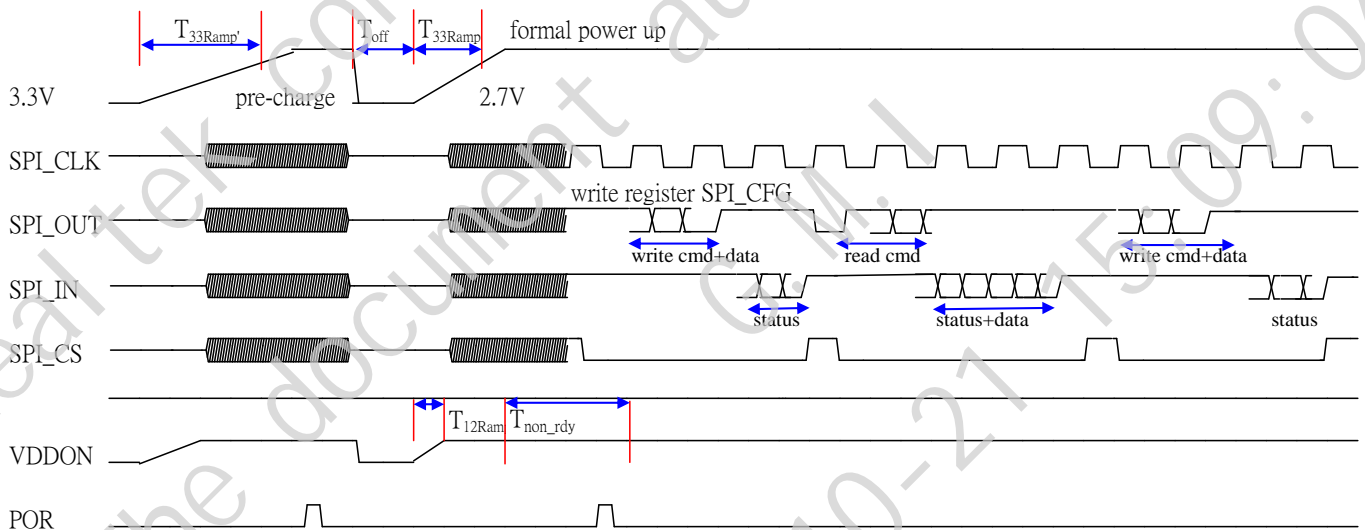
After main 3.3V ramp up and 1.8V ramp up, the power management unit is enabled by the power ready detection circuit. The power management unit enables the SDIO block. eFUSE is then autoloading to SDIO circuits during the  $T_{non\_rdy}$  duration. After CMD5/5/3/7 procedures, card detection is executed. When the driver has loaded, normal CMD52 and CMD53 are used.

**Table 20. SDIO Interface Power-On Timing Parameters**

	Min	Typical	Max	Unit
$T_{33ramp}$	0.1	0.5	2.5	ms
$T_{18ramp}$	0.1	0.5	2.5	ms
$T_{non\_rdy}$	1	2	10	ms

### 6.4.3. GSPI Interface Power-On Sequence

The GSPI (Generic Serial Peripheral Interface) interface is enabled automatically when the first valid GSPI command is received.



**Figure 4. GSPI Interface Power-On Sequence**

**Table 21. GSPI Interface Power-On Sequence**

Symbol	Description
$T_{33ramp}$	3.3V Power Pre-Charge Ramp Up Duration Before Formal Power Up. We recommend that a 3.3V power-on and then power-off sequence is executed by the host controller before the formal power on sequence. This procedure can eliminate host card detection issues when power ramp up duration is too long, or when a system warm reboot fails.

Symbol	Description
$T_{off}$	The duration 3.3V is cut off before formal power up.
$T_{33ramp}$	The 3.3V main power ramp up duration.
$T_{12ramp}$	The internal 1.2V ramp up duration.
$T_{non\_rdy}$	SPI Not Ready Duration. After $T_{non\_rdy}$ , SPI host can then send command to write SPI_CFG register. SPI_CFG register is to control SPI endian and word length.

We recommend that the card detection procedures are divided into two phases: A 3.3V power pre-charge phase and a formal power-up phase.

During the 3.3V power pre-charge phase, the power ramp up duration is not limited. The 3.3V power is cut off and is turned on after the  $T_{off}$  period. The ramp up time is specified in the  $T_{33ramp}$  duration.

After main 3.3V ramp up and 1.2V ramp up, the power management unit is enabled by the power ready detection circuit. The power management unit enables the SPI block. eFUSE is then autoloading to SPI circuits during the  $T_{non\_rdy}$  duration.

**Table 22. SPI Interface Power-On Timing Parameters**

	Min	Typical	Max	Unit
$T_{33ramp}$	-	-	No Limit	ms
$T_{off}$	250	500	1000	ms
$T_{33ramp}$	0.1	0.5	2.5	ms
$T_{12ramp}$	0.1	0.5	1.5	ms
$T_{non\_rdy}$	3	4	18	ms

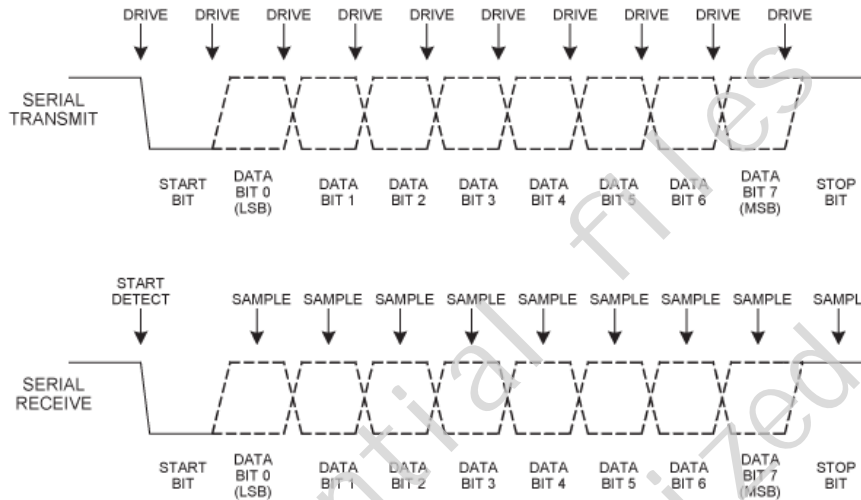
## 6.5. UART Interface Characteristics

The RTL8723CS-CG UART interface is a standard 4-wire interface with RX, TX, CTS, and RTS. The interface supports the Bluetooth 2.0 UART HCI H4 and H5 specifications. The default baud rate is 115.2k baud. In order to support high and low speed baud rate, the RTL8723CS-CG provides multiple UART clocks.

**Table 23. UART Interface Power-On Timing Parameters**

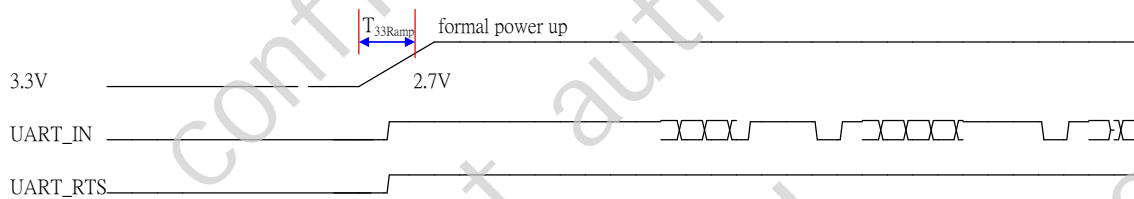
Desired Baud Rate	Actual Baud Rate	Error (%)
300	300	0.00%
600	600	0.00%
900	900	0.00%
1200	1200	0.00%
1800	1800	0.00%
2400	2400	0.00%
3600	3601	0.03%
4800	4798	-0.04%
7200	7198	-0.03%
9600	9603	0.03%
14400	14395	-0.03%
19200	19182	-0.09%
28800	28846	0.16%
38400	38462	0.16%
56000	55970	-0.05%
57600	57692	0.16%
76800	76531	-0.35%
115200	115385	0.16%
128000	127119	-0.69%
153600	153061	-0.35%
230400	229167	-0.54%
460800	458333	-0.54%
500000	500000	0.00%
921600	916667	-0.54%
1000000	1000000	0.00%
1382400	1375000	-0.54%
1444444	1437500	-0.48%
1500000	1500000	0.00%
1843200	1833333	-0.54%
2000000	2000000	0.00%
2100000	2083333	-0.79%
2764800	2777778	0.47%
3000000	3000000	0.00%
3250000	3250000	0.00%
3692300	3703704	0.31%

Desired Baud Rate	Actual Baud Rate	Error (%)
3750000	3750000	0.00%
4000000	4000000	0.00%



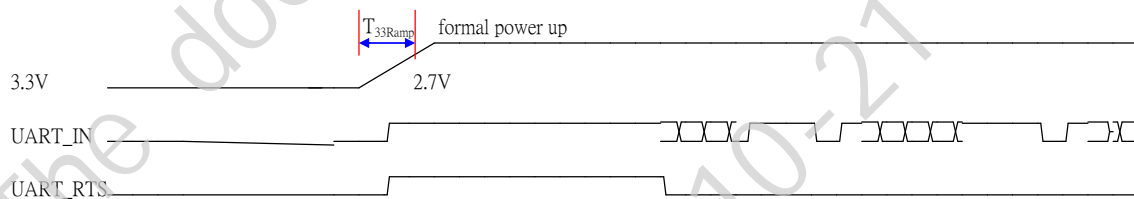
**Figure 5. UART Interface Waveform**

### UART Hardware Flow Control Not Supported



**Figure 6. UART Power-On Sequence Without Hardware Flow Control**

### UART Hardware Flow Control Supported



**Figure 7. UART Power-On Sequence With Hardware Flow Control**

**Table 24. UART Interface Power-On Sequence Parameters**

Symbol	Description
$T_{33ramp}$	The 3.3V main power ramp up duration.



**Table 25. UART Interface Power-On Timing Specifications**

Symbol	Min	Typical	Max	Unit
T <sub>33ramp</sub>	0.1	0.5	2.5	ms

Realtek confidential files  
The document authorized to  
G.M.I  
2015-10-27 15:09:04

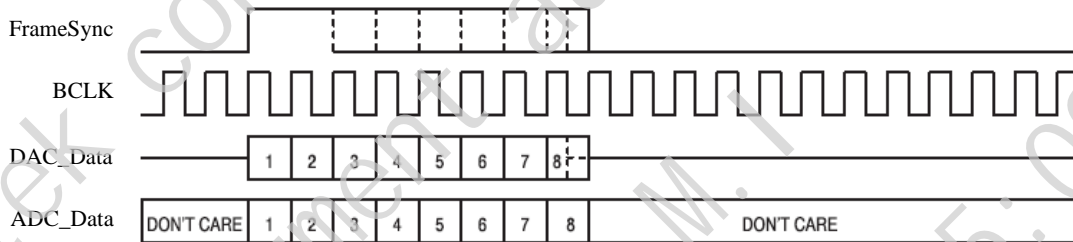
## 6.6. PCM Interface Characteristics

The RTL8723 supports a PCM digital audio interface that is used for transmitting digital audio/voice data to/from the Audio Codec. Features are supported as below:

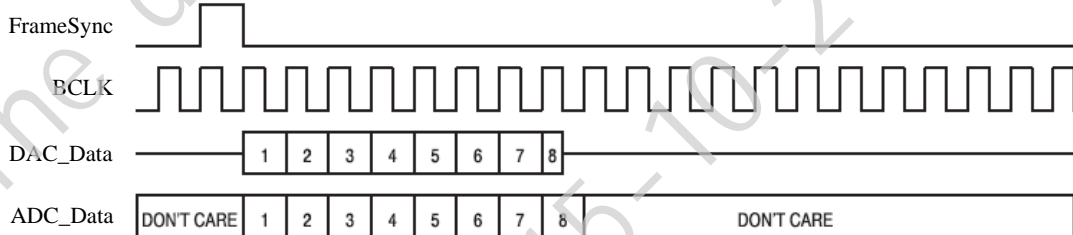
- Supports Master and Slave mode
- Programmable long/short Frame Sync
- Supports 8-bit A-law/ $\mu$ -law, and 13/16-bit linear PCM formats
- Supports sign-extension and zero-padding for 8-bit and 13-bit samples
- Supports padding of Audio Gain to 13-bit samples
- PCM Master Clock Output: 64, 128, 256, or 512kHz
- Supports SCO/ESCO link

### 6.6.1. PCM Format

FrameSync is the synchronizing function used to control the transfer of DAC\_Data and ADC\_Data. A Long FrameSync indicates the start of ADC\_Data at the rising edge of FrameSync (Figure 8), and a Short FrameSync indicates the start of ADC\_Data at the falling edge of FrameSync (Figure 9).



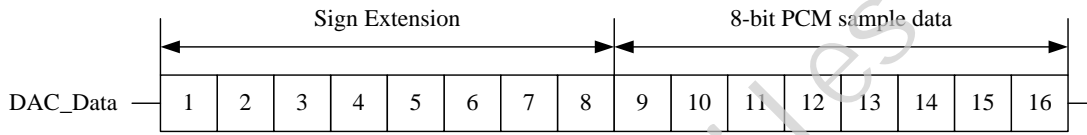
**Figure 8. Long FrameSync**



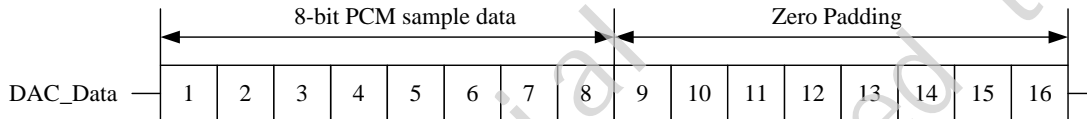
**Figure 9. Short FrameSync**

### 6.6.2. Sign Extension and Zero Padding for 8-Bit and 13-Bit Samples

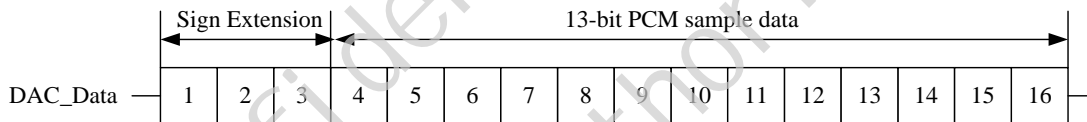
For 16-bit linear PCM output, 3 or 8 unused bits may be sign extended/zero padded.



**Figure 10. 16-Bit Output Data with 8-Bit PCM Sample Data and Sign Extension**

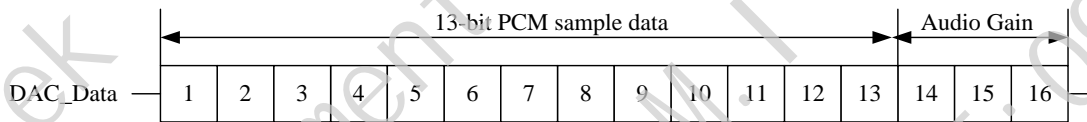


**Figure 11. 16-Bit Output Data with 8-Bit PCM Sample Data and Zero Padding**



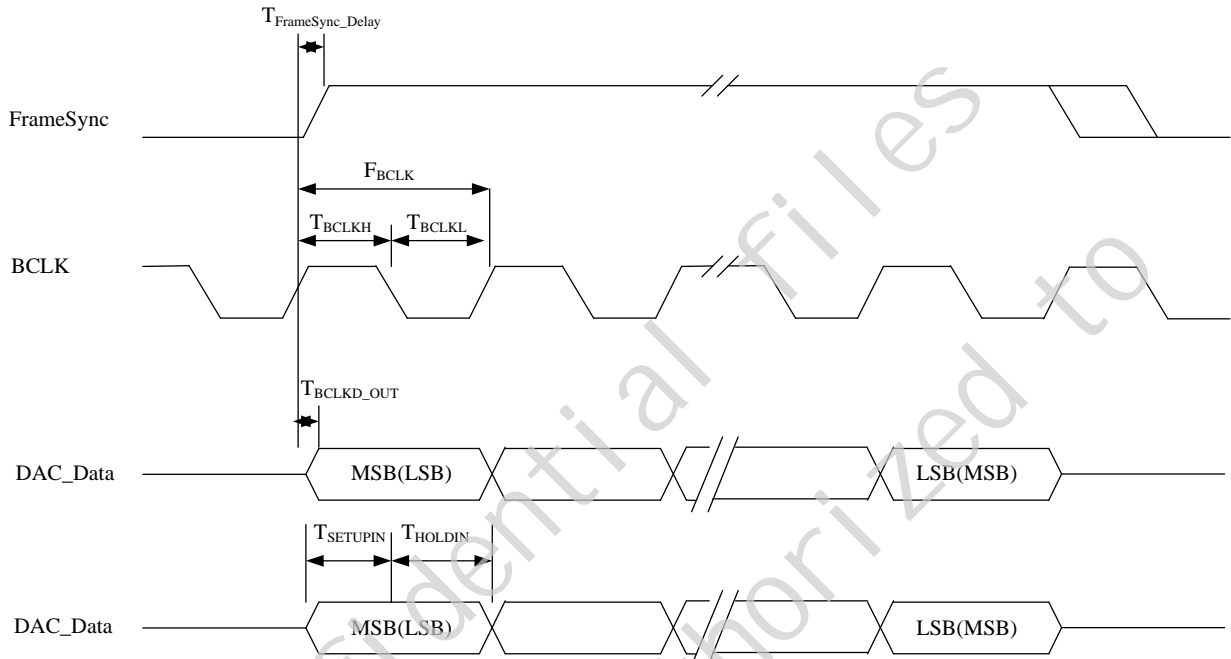
**Figure 12. 16-Bit Output Data with 13-Bit PCM Sample Data and Sign Extension**

For 16-bit linear PCM output, 3-bit programmable audio gain value can be padded to 13-bit sample data.

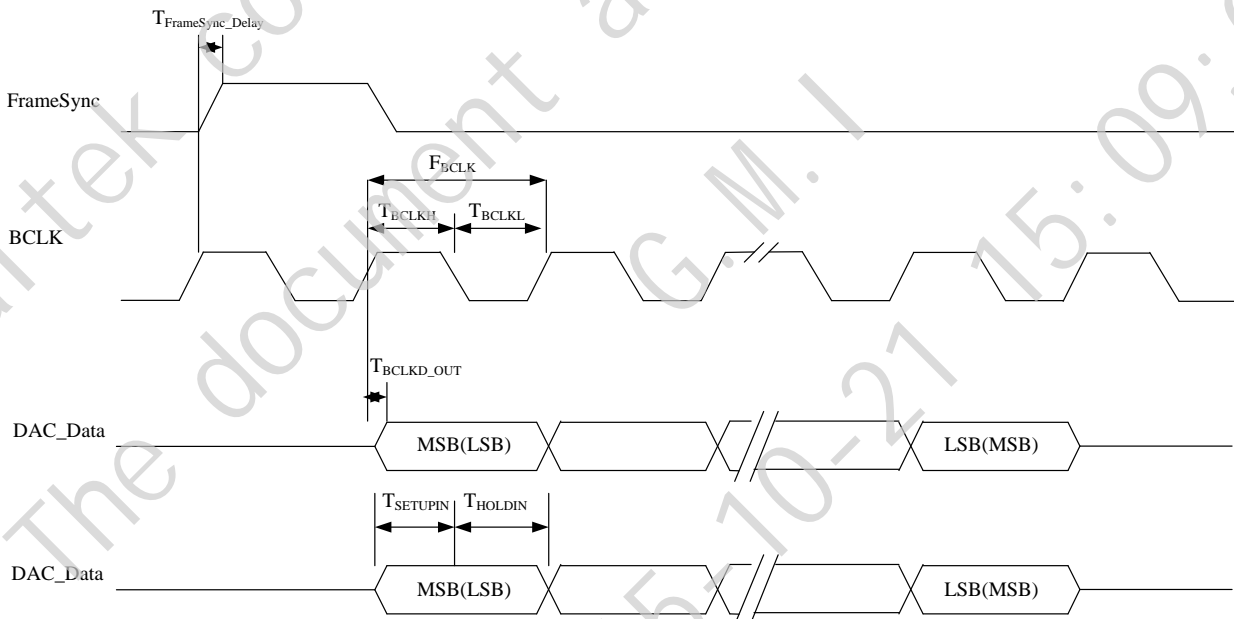


**Figure 13. 16-Bit Output Data with 13-Bit PCM Sample Data and Audio Gain**

### 6.6.3. PCM Interface Timing



**Figure 14. PCM Interface (Long FrameSync)**



**Figure 15. PCM Interface (Short FrameSync)**

**Table 26. PCM Interface Clock Specifications**

Symbol	Description	Min.	Typ.	Max.	Unit
$F_{BCLK}$	Frequency of BCLK (Master)	64	-	512	kHz
$F_{FrameSync}$	Frequency of Frame Sync (Master)	-	8	-	kHz
$F_{BCLK}$	Frequency of BCLK (Slave)	64	-	512	kHz
$F_{FrameSync}$	Frequency of Frame Sync (Slave)	-	8	-	kHz
D	Data Size	8	8	16	bits
N	Number of Slots Per Frame	1	1	1	Slots

**Table 27. PCM Interface Timing**

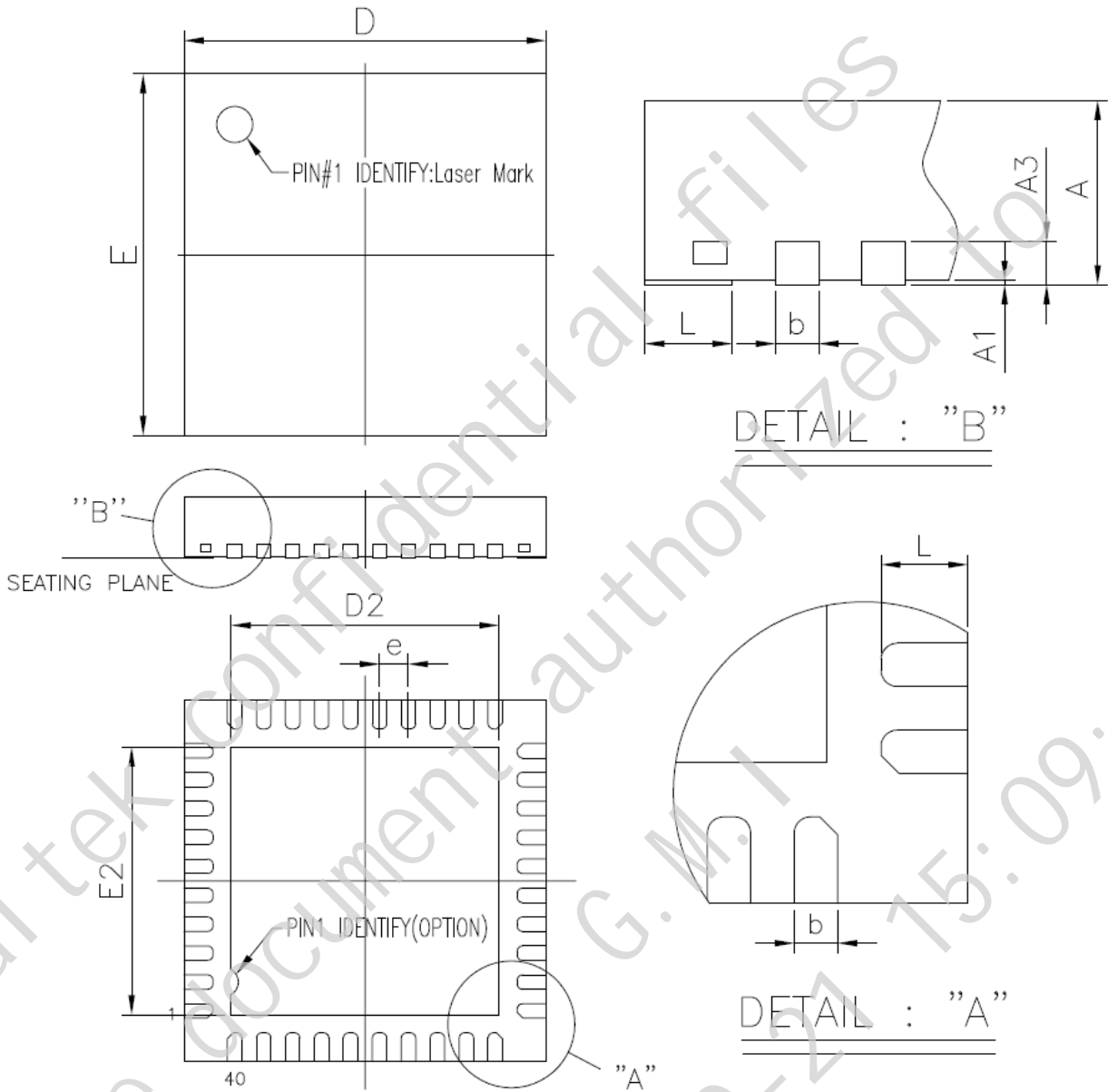
Symbol	Description	Min.	Typ.	Max.	Unit
$T_{BCLKH}$	High Period of BCLK	980	-	-	ns
$T_{BCLKL}$	Low Period of BCLK	970	-	-	ns
$T_{FrameSync\_Delay}$	Delay Time from BCLK High to Frame Sync High	-	-	75	ns
$T_{BCLKD\_OUT}$	Delay Time from BCLK High to Valid DAC_Data	-	-	125	ns
$T_{SETUPIN}$	Set-up Time for ADC_Data Valid to BCLK Low	10	-	-	ns
$T_{HOLDIN}$	Hold Time for BCLK Low to ADC_Data Invalid	125	-	-	ns

#### 6.6.4. PCM Interface Signal Levels

The PCM signal level ranges from 1.8V to 3.3V. The host provides the power source with the targeted power level to the RTL8723CS-CG PCM interface via the VDD\_IO pin (pin 26).

The 3.3V, 2.8V, and 1.8V DC characteristics of typical signal levels are shown in section 6.3 Digital IO Pin DC Characteristics, page 12.

## 7. Mechanical Dimensions



## 7.1. Mechanical Dimensions Notes

Symbol	Dimension in mm			Dimension in inch		
	Min	Nom	Max	Min	Nom	Max
A	0.80	0.85	0.90	0.031	0.033	0.035
A1	0.00	0.02	0.05	0.000	0.001	0.002
A3	0.20 REF			0.008 REF		
b	0.15	0.20	0.25	0.006	0.008	0.010
D/E	5.00 BSC			0.197 BSC		
D2/E2	3.45	3.60	3.75	0.136	0.142	0.148
e	0.40 BSC			0.016 BSC		
L	0.30	0.40	0.50	0.012	0.016	0.020

Notes :

1. CONTROLLING DIMENSION : MILLIMETER(mm).
2. REFERENCE DOCUMENTL : JEDEC MO-220.

## 8. Ordering Information

**Table 28. Ordering Information**

Part Number	Package	Status
RTL8723CS-CG	QFN-40, 'Green' Package	ES

*Note: See page 6 for package identification.*

---

**Realtek Semiconductor Corp.****Headquarters**

No. 2, Innovation Road II, Hsinchu Science Park,  
Hsinchu 300, Taiwan, R.O.C.

Tel: 886-3-5780211 Fax: 886-3-5776047

[www.realtek.com](http://www.realtek.com)