

Features

- -100V/-13A,
 $R_{DS(ON)} = 160m$ (Typ.) @ $V_{GS} = -10V$
 $R_{DS(ON)} = 180m$ (Typ.) @ $V_{GS} = -4.5V$
- Super High Dense Cell Design
- ESD protected
- Reliable and Rugged
- 100% avalanche tested
- Lead Free and Green Devices Available
 (RoHS Compliant)

Applications

- Power Management
- DC/DC Converters

Pin Description

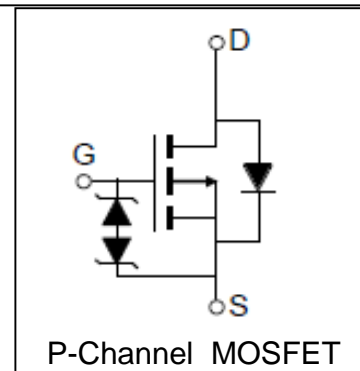
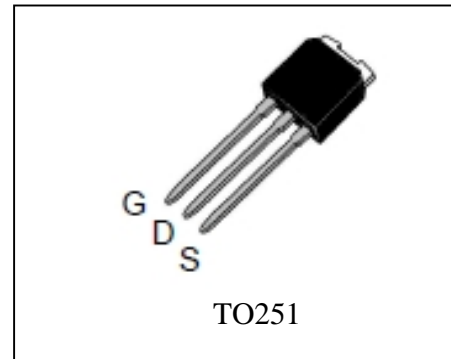

Absolute Maximum Ratings

Symbol	Parameter	Rating	Unit	
Common Ratings ($T_C = 25^\circ C$ Unless Otherwise Noted)				
V_{DSS}	Drain-Source Voltage	-100	V	
V_{GSS}	Gate-Source Voltage	± 20		
T_J	Maximum Junction Temperature	175	$^\circ C$	
T_{STG}	Storage Temperature Range	-55 to 175	$^\circ C$	
I_S	Diode Continuous Forward Current	$T_C = 25^\circ C$ -13	A	
Mounted on Large Heat Sink				
I_{DP}	300 μs Pulse Drain Current Tested	$T_C = 25^\circ C$ -52 ^①	A	
I_D	Continuous Drain Current ($V_{GS} = -10V$)	$T_C = 25^\circ C$	-13	A
		$T_C = 100^\circ C$	-9	
P_D	Maximum Power Dissipation	$T_C = 25^\circ C$	50	W
		$T_C = 100^\circ C$	25	
$R_{\theta JC}$	Thermal Resistance-Junction to Case	3	$^\circ C/W$	
Drain-Source Avalanche Ratings				
E_{AS} ^②	Avalanche Energy, Single Pulsed	56	mJ	

Electrical Characteristics ($T_C=25^\circ\text{C}$ Unless Otherwise Noted)

Symbol	Parameter	Test Condition	RU1HL13K			Unit
			Min.	Typ.	Max.	
Static Characteristics						
BV_{DSS}	Drain-Source Breakdown Voltage	$V_{GS}=0V, I_{DS}=-250\mu A$	-100			V
I_{DSS}	Zero Gate Voltage Drain Current	$V_{DS}=-100V, V_{GS}=0V$ $T_J=85^\circ\text{C}$			-1	μA
$V_{GS(th)}$	Gate Threshold Voltage	$V_{DS}=V_{GS}, I_{DS}=-250\mu A$	-1.5	-2	-2.7	V
I_{GSS}	Gate Leakage Current	$V_{GS}=\pm 16V, V_{DS}=0V$			± 10	μA
$R_{DS(ON)}^{(3)}$	Drain-Source On-state Resistance	$V_{GS}=-10V, I_{DS}=-8A$		160	200	$m\Omega$
		$V_{GS}=-4.5V, I_{DS}=-6A$		180	250	$m\Omega$
Diode Characteristics						
$V_{SD}^{(3)}$	Diode Forward Voltage	$I_{SD}=-1A, V_{GS}=0V$			-1.2	V
t_{rr}	Reverse Recovery Time	$I_{SD}=-13A, dI_{SD}/dt=100A/\mu s$		35		ns
Q_{rr}	Reverse Recovery Charge			65		nC
Dynamic Characteristics ⁽⁴⁾						
R_G	Gate Resistance	$V_{GS}=0V, V_{DS}=0V, F=1\text{MHz}$		10		Ω
C_{iss}	Input Capacitance	$V_{GS}=0V,$ $V_{DS}=-25V,$ Frequency=1.0MHz		1089		pF
C_{oss}	Output Capacitance			616		
C_{rss}	Reverse Transfer Capacitance			191		
$t_{d(ON)}$	Turn-on Delay Time	$V_{DD}=-50V, R_L=3.8\Omega,$ $I_{DS}=-13A, V_{GEN}=-10V,$ $R_G=6\Omega$		13		ns
t_r	Turn-on Rise Time			16		
$t_{d(OFF)}$	Turn-off Delay Time			31		
t_f	Turn-off Fall Time			18		
Gate Charge Characteristics ⁽⁴⁾						
Q_g	Total Gate Charge	$V_{DS}=-80V, V_{GS}=-10V,$ $I_{DS}=-13A$		28		nC
Q_{gs}	Gate-Source Charge			9		
Q_{gd}	Gate-Drain Charge			10		

- Notes: ① Pulse width limited by safe operating area.
 ② Limited by $T_{Jmax}, I_{AS}=15A, V_{DD}=-48V, R_G=50\Omega$, Starting $T_J=25^\circ\text{C}$.
 ③ Pulse test; Pulse width $\leq 300\mu s$, duty cycle $\leq 2\%$.
 ④ Guaranteed by design, not subject to production testing.

Typical Characteristics

Power Dissipation

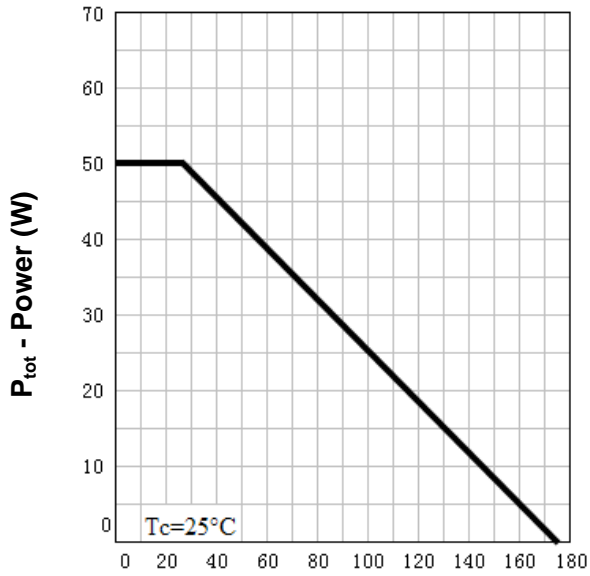

T_j - Junction Temperature (°C)

Drain Current

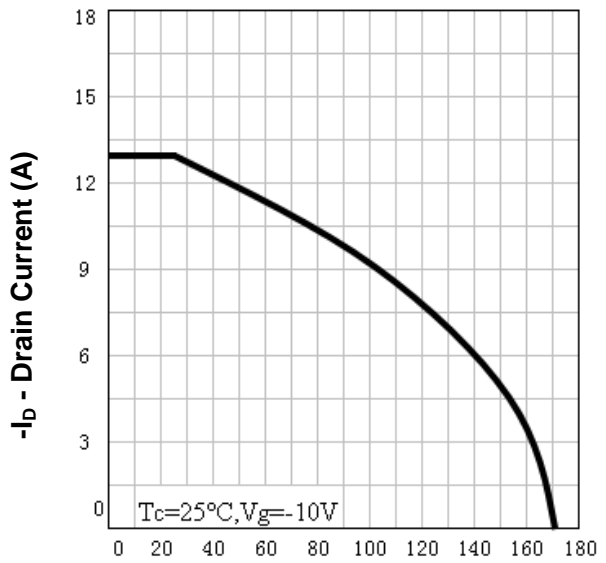

T_j - Junction Temperature (°C)

Safe Operation Area

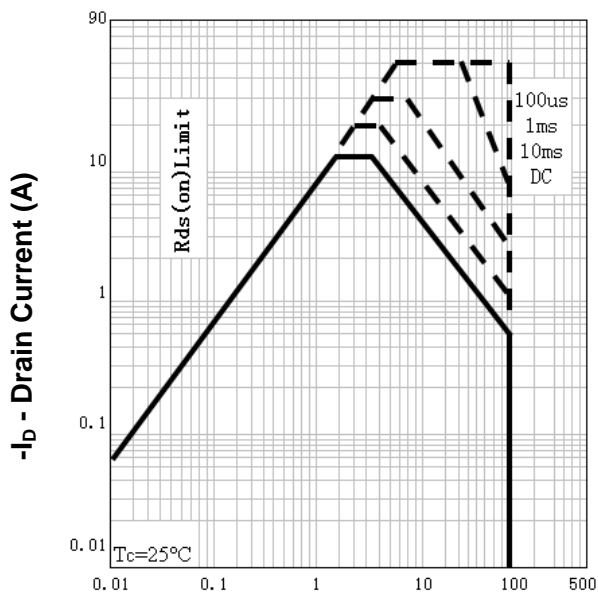

-V_{DS} - Drain-Source Voltage (V)

Thermal Transient Impedance

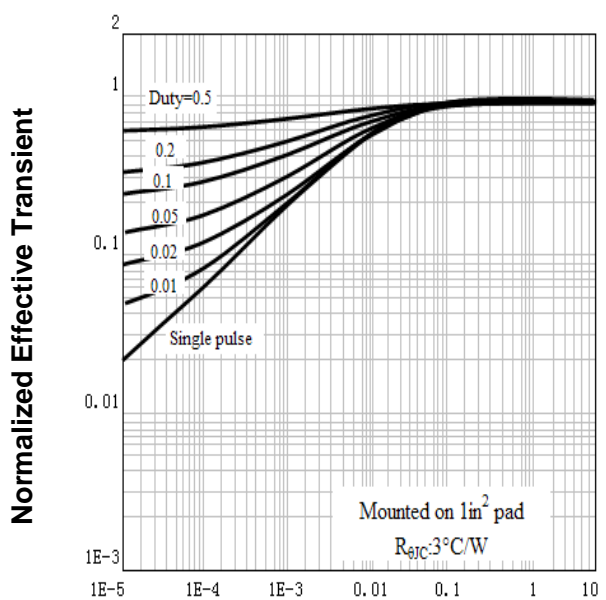

Square Wave Pulse Duration (sec)

Typical Characteristics

Output Characteristics

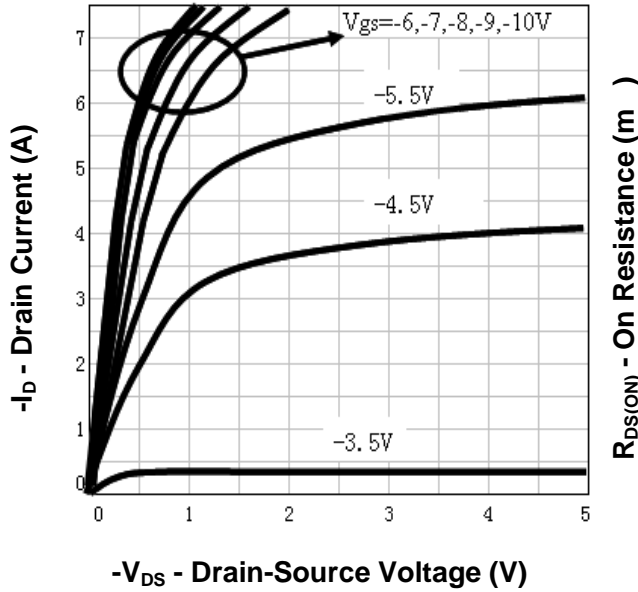

Drain-Source On Resistance

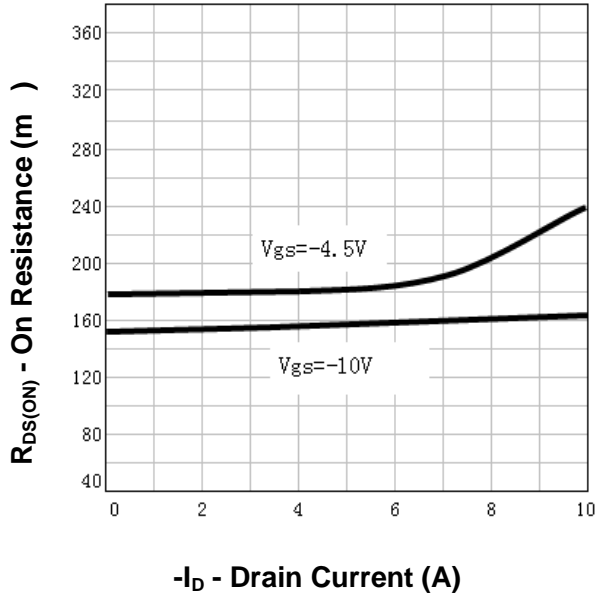

Drain-Source On Resistance

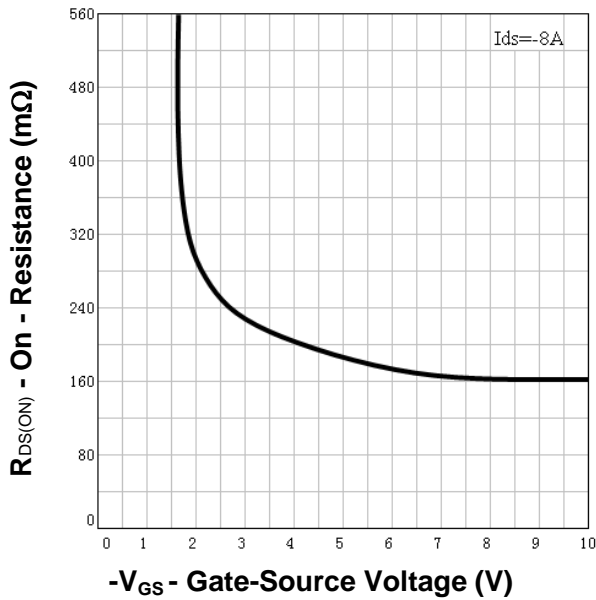

Gate Threshold Voltage

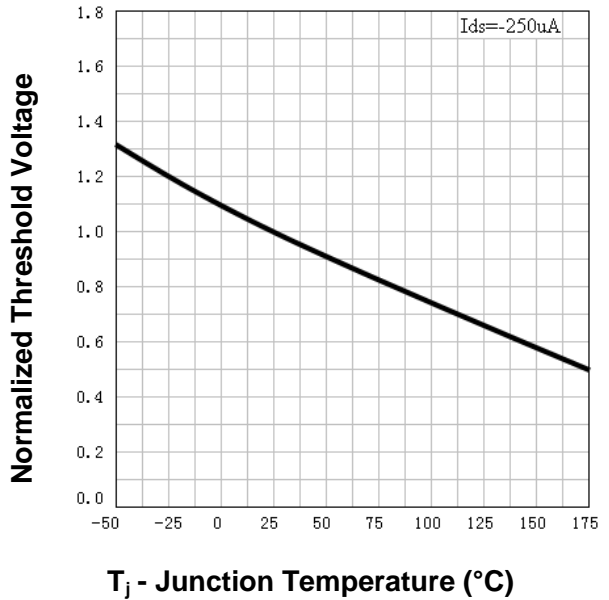

Typical Characteristics

Drain-Source On Resistance

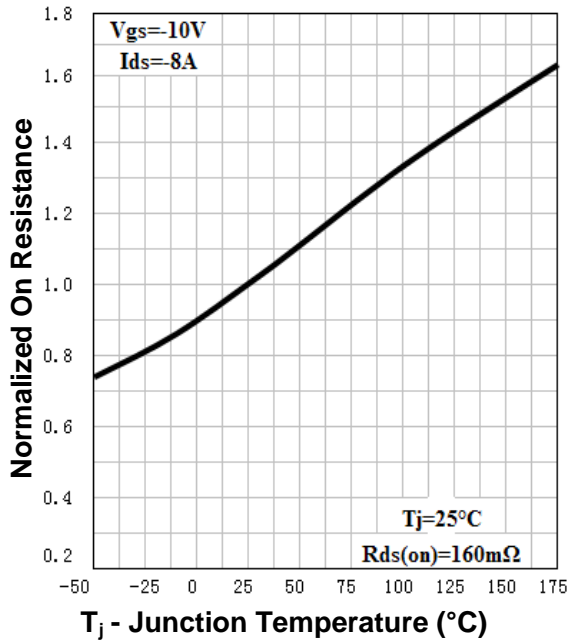

Source-Drain Diode Forward

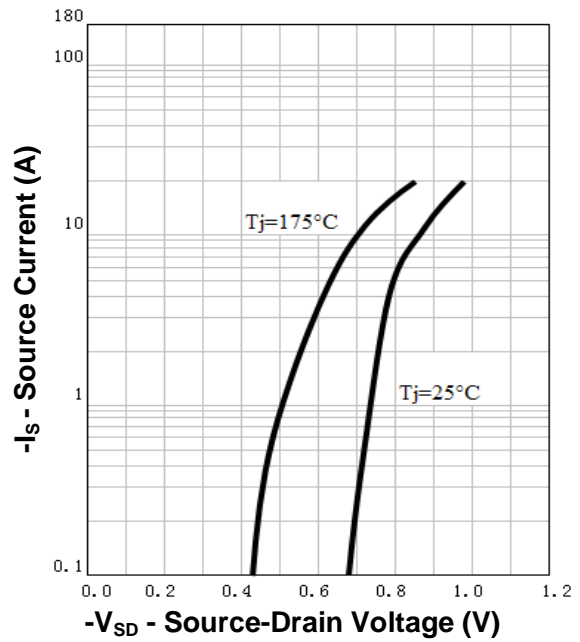

Capacitance

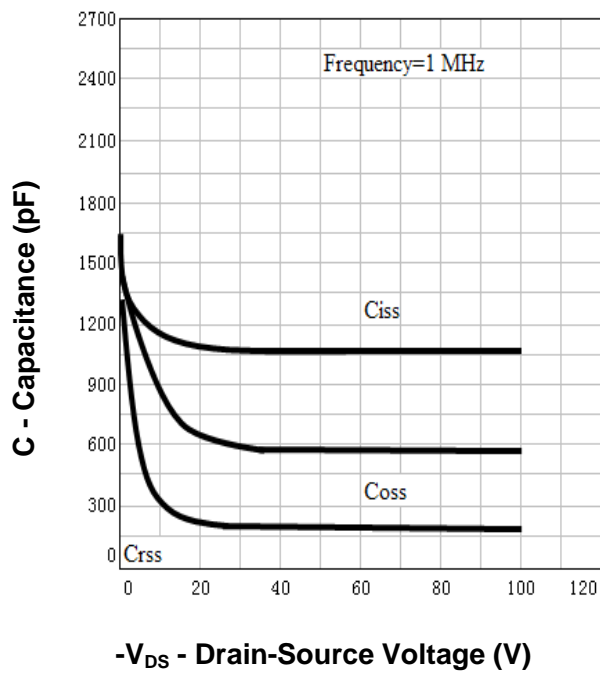

Gate Charge

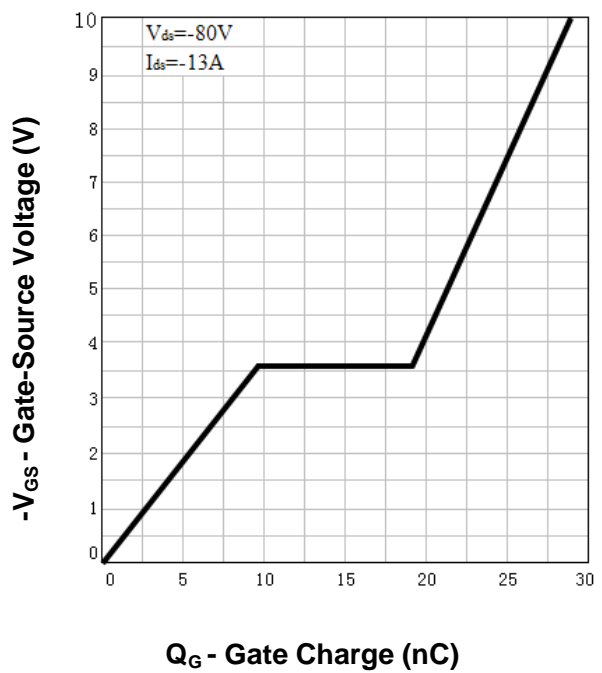

Avalanche Test Circuit and Waveforms

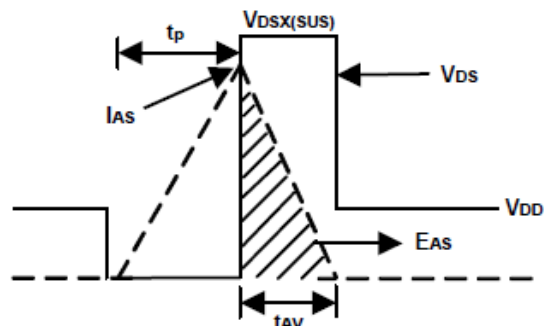
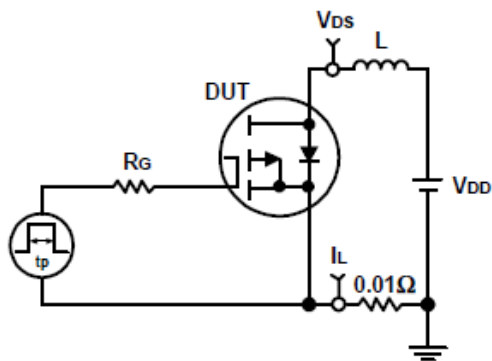

Switching Time Test Circuit and Waveforms

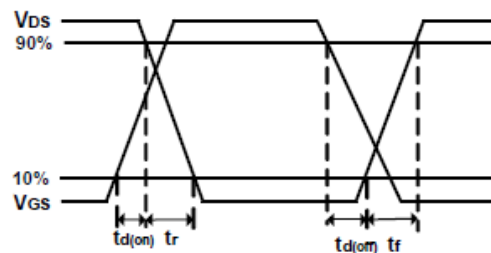
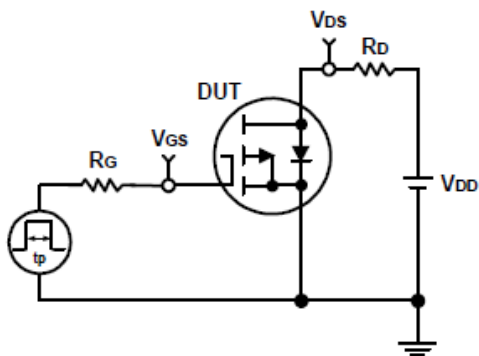

Ordering and Marking Information

Device	Marking	Package	Packaging	Quantity	Reel Size	Tape width
RU1HL13K	RU1HL13K	TO-251	Tube	72	-	-

Package Information

TO251

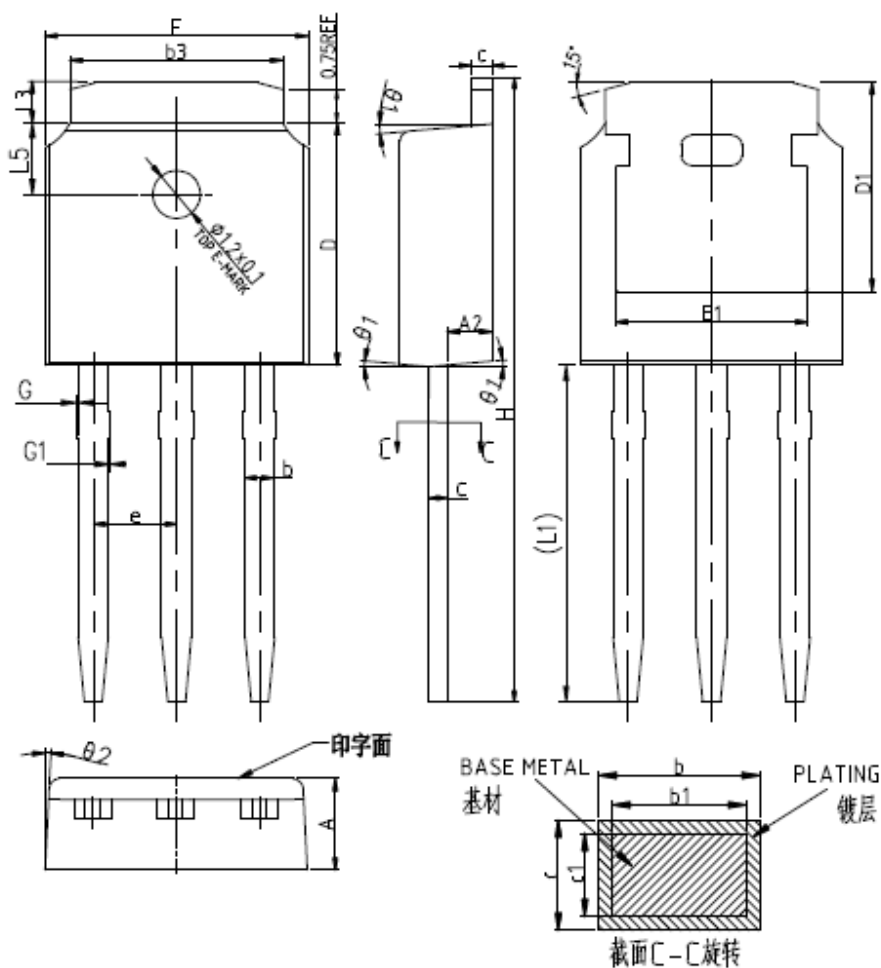

SYMBOL	MM			INCH			SYMBOL	MM			INCH		
	MIN	NOM	MAX	MIN	NOM	MAX		MIN	NOM	MAX	MIN	NOM	MAX
A	2.20	2.30	2.38	0.087	0.091	0.094	E	6.50	6.60	6.70	0.256	0.260	0.264
A2	0.97	1.07	1.17	0.038	0.042	0.046	E1	4.70	4.83	4.92	0.185	0.190	0.194
b	0.72	0.78	0.85	0.028	0.031	0.033	e	2.286BSC			0.090BSC		
b1	0.71	0.76	0.81	0.028	0.030	0.032	H	16.10	16.40	16.60	0.634	0.646	0.654
b3	5.23	5.33	5.46	0.206	0.210	0.215	L1	9.20	9.40	9.60	0.362	0.370	0.378
c	0.47	0.53	0.58	0.019	0.021	0.023	L3	0.90	1.02	1.25	0.035	0.040	0.049
c1	0.46	0.51	0.56	0.018	0.020	0.022	L5	1.70	1.80	1.90	0.067	0.071	0.075
D	6.00	6.10	6.20	0.236	0.240	0.244	1	5°	7°	9°	5°	7°	9°
D1	5.30REF			0.209REF			2	5°	7°	9°	5°	7°	9°

**ALL DIMENSIONS REFER TO JEDEC STANDARD
DO NOT INCLUDE MOLD FLASH OR PROTRUSIONS**

Customer Service

Worldwide Sales and Service:

Sales@ruichips.com

Technical Support:

Technical@ruichips.com

Investor Relations Contacts:

Investor@ruichips.com

Marcom Contact:

Marcom@ruichips.com

Editorial Contact:

Editorial@ruichips.com

HR Contact:

HR@ruichips.com

Legal Contact:

Legal@ruichips.com

Shen Zhen RUICHIPS Semiconductor CO., LTD

Room 501, the 5floor An Tong Industrial Building,
NO.207 Mei Hua Road Fu Tian Area Shen Zhen City, CHINA

TEL: (86-755) 8311-5334

FAX: (86-755) 8311-4278

E-mail: Sales-SZ@ruichips.com