

Features

- 20V/120A,
 $R_{DS(ON)} = 2.3m\Omega(Typ.)@V_{GS}=10V$
 $R_{DS(ON)} = 4.2m\Omega(Typ.)@V_{GS}=4.5V$
- Super High Dense Cell Design
- Reliable and Rugged
- 100% avalanche tested
- 175°C Operating Temperature
- Lead Free and Green Devices Available (RoHS Compliant)

Applications

- Power Management
- DC-DC Converters

Pin Description

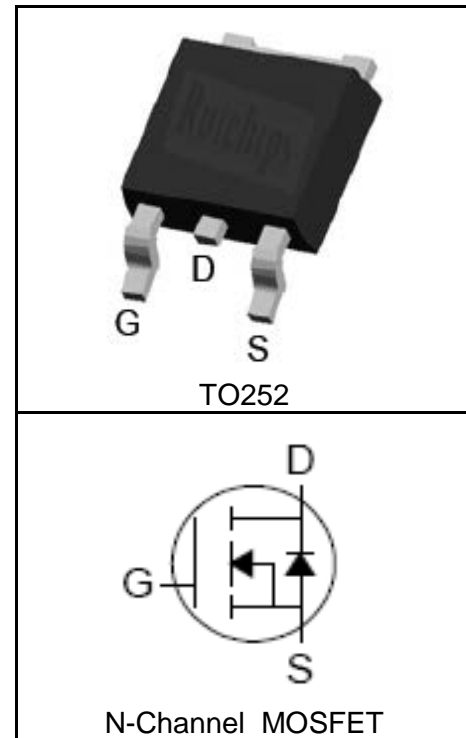

Absolute Maximum Ratings

Symbol	Parameter	Rating	Unit
Common Ratings ($T_C=25^\circ C$ Unless Otherwise Noted)			
V_{DSS}	Drain-Source Voltage	20	V
V_{GSS}	Gate-Source Voltage	± 20	
T_J	Maximum Junction Temperature	175	$^\circ C$
T_{STG}	Storage Temperature Range	-55 to 175	$^\circ C$
I_S	Diode Continuous Forward Current	$T_C=25^\circ C$ 120	A
Mounted on Large Heat Sink			
$I_{DP}^{①}$	300 μs Pulse Drain Current Tested	$T_C=25^\circ C$ 480	A
$I_D^{②}$	Continuous Drain Current($V_{GS}=10V$)	$T_C=25^\circ C$ 120	A
		$T_C=100^\circ C$ 93	
P_D	Maximum Power Dissipation	$T_C=25^\circ C$ 103	W
		$T_C=100^\circ C$ 52	
$R_{\theta JC}$	Thermal Resistance-Junction to Case	1.45	$^\circ C/W$
$R_{\theta JA}$	Thermal Resistance-Junction to Ambient	100	$^\circ C/W$
Drain-Source Avalanche Ratings			
$E_{AS}^{③}$	Avalanche Energy, Single Pulsed	64	mJ

Electrical Characteristics ($T_C=25^\circ\text{C}$ Unless Otherwise Noted)

Symbol	Parameter	Test Condition	RU20120L			Unit
			Min.	Typ.	Max.	
Static Characteristics						
BV_{DSS}	Drain-Source Breakdown Voltage	$V_{GS}=0V, I_{DS}=250\mu A$	20			V
I_{DSS}	Zero Gate Voltage Drain Current	$V_{DS}=20V, V_{GS}=0V$			1	μA
		$T_J=125^\circ C$			30	
$V_{GS(th)}$	Gate Threshold Voltage	$V_{DS}=V_{GS}, I_{DS}=250\mu A$	1		2.5	V
I_{GSS}	Gate Leakage Current	$V_{GS}=\pm 20V, V_{DS}=0V$			± 100	nA
$R_{DS(ON)}^{④}$	Drain-Source On-state Resistance	$V_{GS}=10V, I_{DS}=60A$		2.3	2.8	$m\Omega$
		$V_{GS}=4.5V, I_{DS}=40A$		4.2	5	$m\Omega$
Diode Characteristics						
$V_{SD}^{④}$	Diode Forward Voltage	$I_{SD}=60A, V_{GS}=0V$			1.2	V
t_{rr}	Reverse Recovery Time	$I_{SD}=60A, di_{SD}/dt=100A/\mu s$		75		ns
Q_{rr}	Reverse Recovery Charge			140		nC
Dynamic Characteristics^⑤						
R_G	Gate Resistance	$V_{GS}=0V, V_{DS}=0V, F=1MHz$		1.5		Ω
C_{iss}	Input Capacitance	$V_{GS}=0V, V_{DS}=10V, Frequency=1.0MHz$		2750		pF
C_{oss}	Output Capacitance			520		
C_{riss}	Reverse Transfer Capacitance			280		
$t_{d(ON)}$	Turn-on Delay Time	$V_{DD}=10V, R_L=0.15\Omega, I_{DS}=60A, V_{GEN}=10V, R_G=6\Omega$		10		ns
t_r	Turn-on Rise Time			26		
$t_{d(OFF)}$	Turn-off Delay Time			22		
t_f	Turn-off Fall Time			15		
Gate Charge Characteristics^⑤						
Q_g	Total Gate Charge	$V_{DS}=16V, V_{GS}=10V, I_{DS}=60A$		28		nC
Q_{gs}	Gate-Source Charge			7		
Q_{gd}	Gate-Drain Charge			9		

- Notes:
- ① Pulse width limited by safe operating area.
 - ② Calculated continuous current based on maximum allowable junction temperature. The package limitation current is 60A.
 - ③ Limited by T_{Jmax} , $I_{AS}=16A, V_{DD}=12V, R_G=50\Omega$, Starting $T_J=25^\circ C$.
 - ④ Pulse test; Pulse width $\leq 300\mu s$, duty cycle $\leq 2\%$.
 - ⑤ Guaranteed by design, not subject to production testing.

Ordering and Marking Information

Device	Marking	Package	Packaging	Quantity	Reel Size	Tape width
RU20120L	RU20120L	TO252	Tape&Reel	2500	13"	16mm

Typical Characteristics

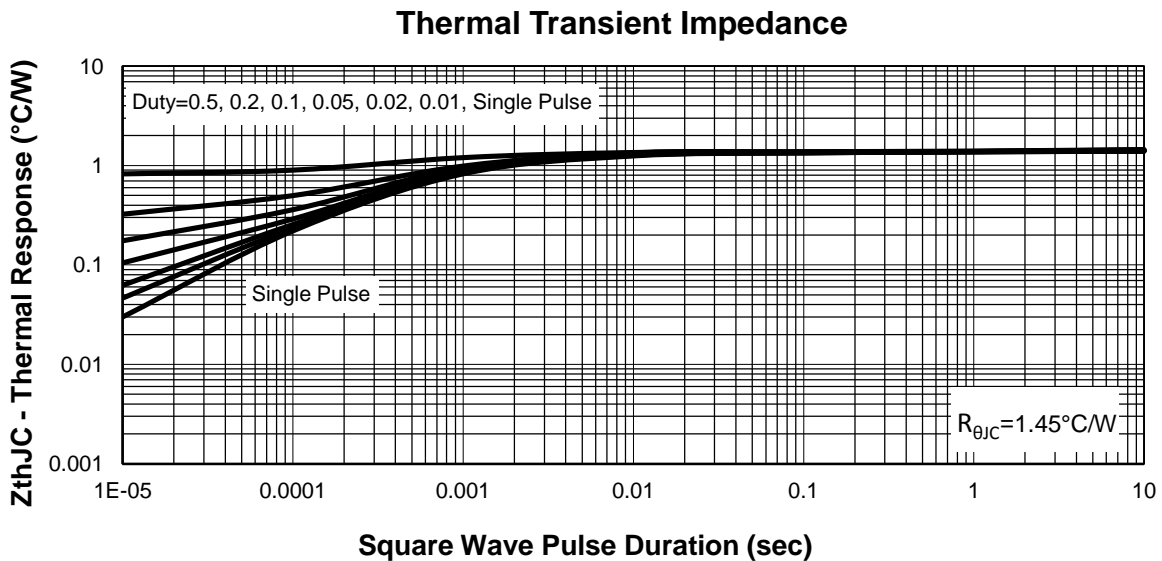
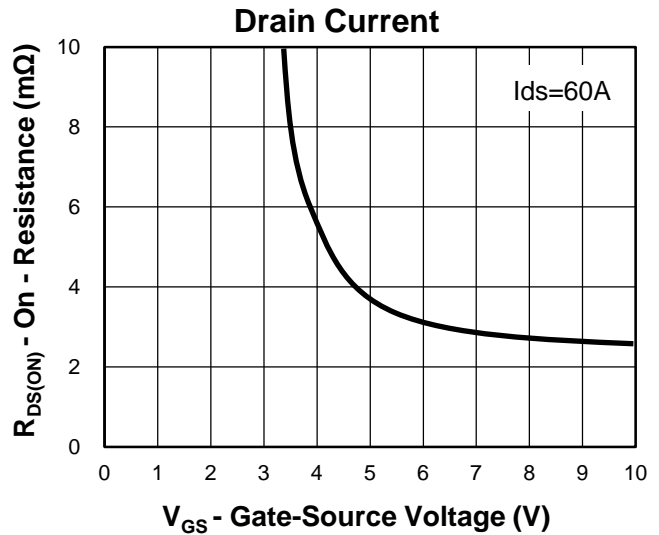
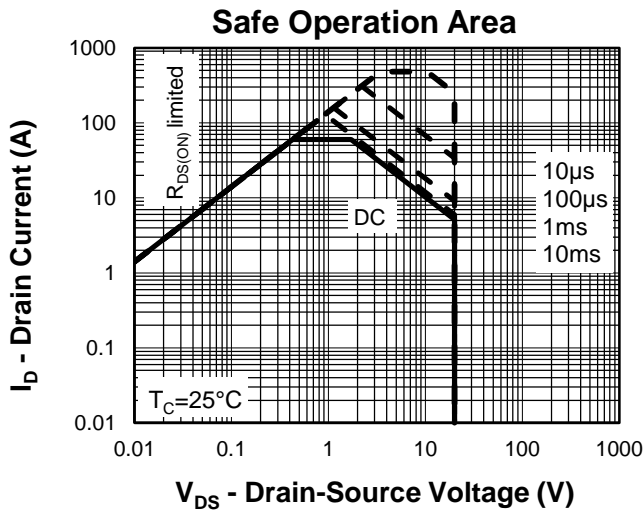
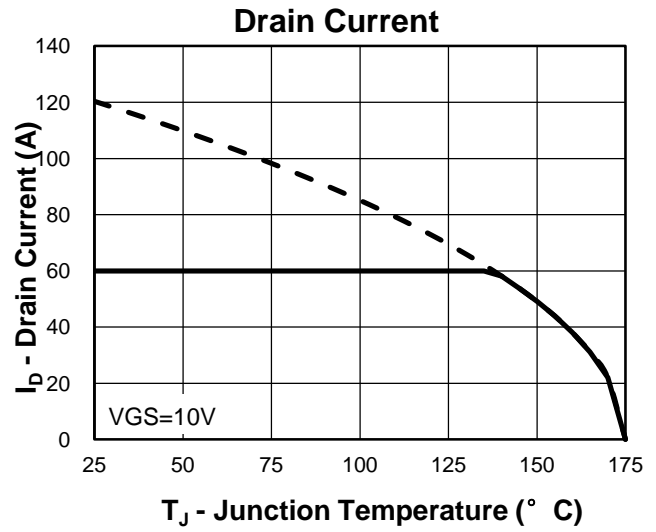
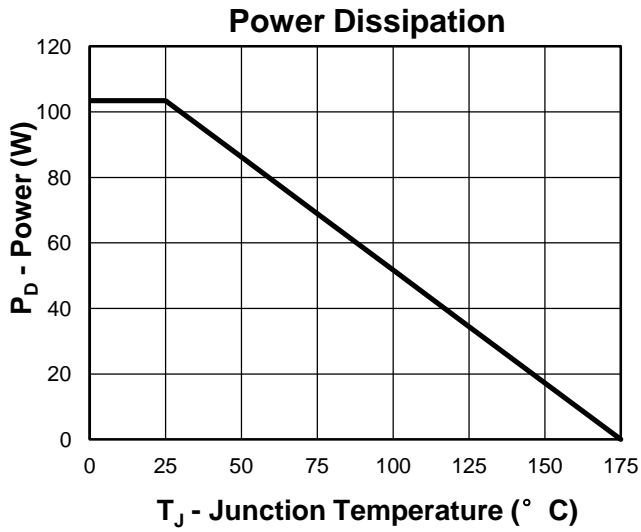

Typical Characteristics

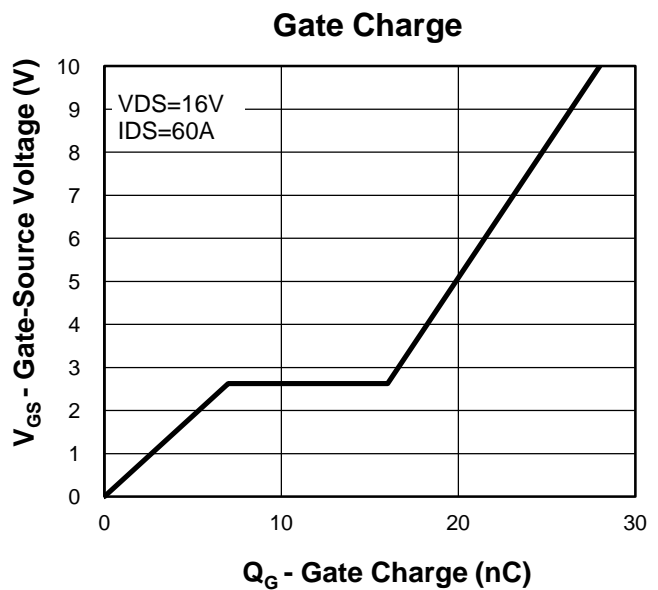
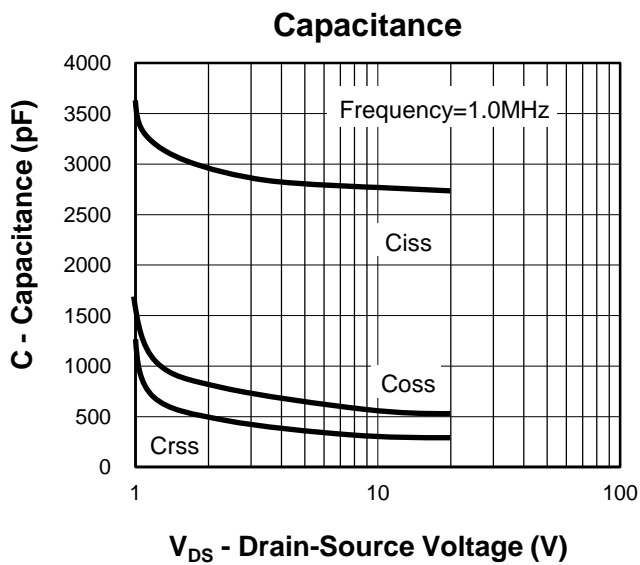
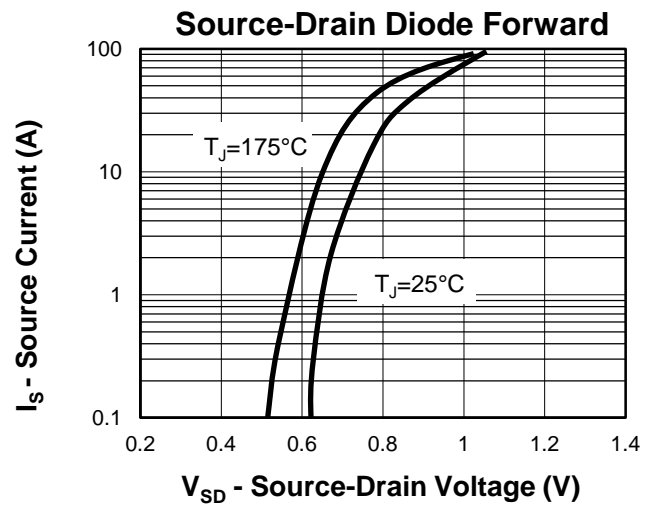
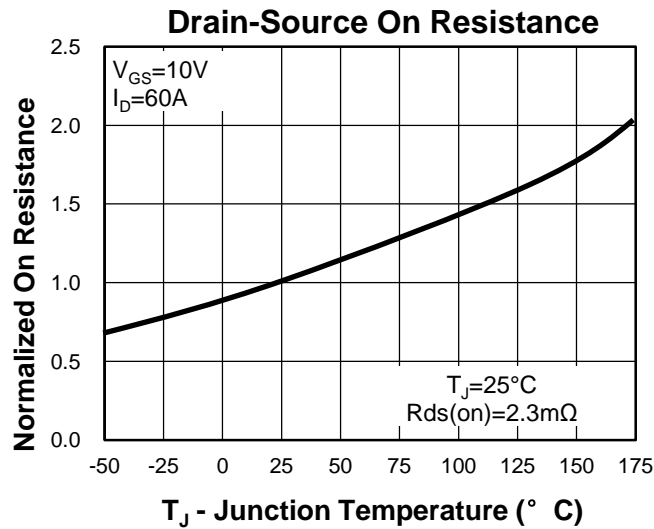
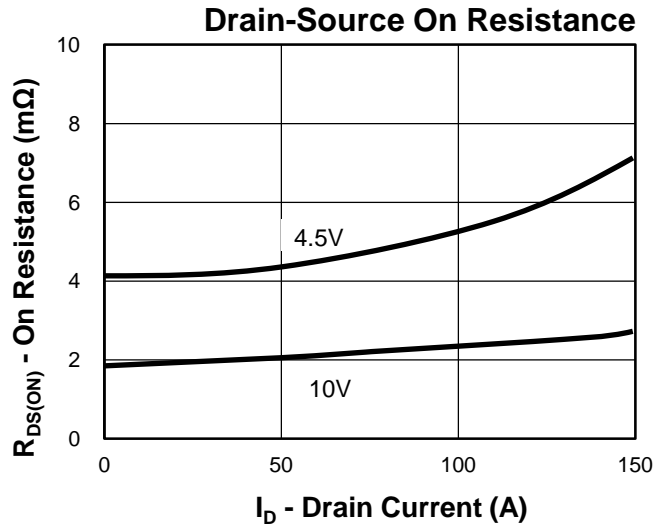
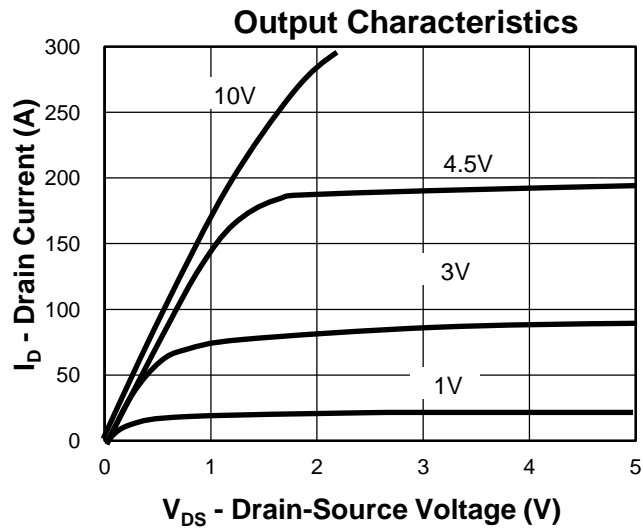

Avalanche Test Circuit and Waveforms

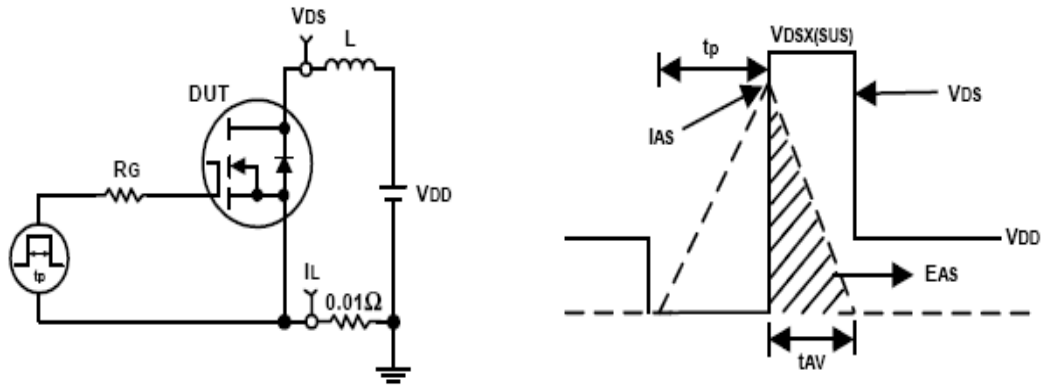

Switching Time Test Circuit and Waveforms

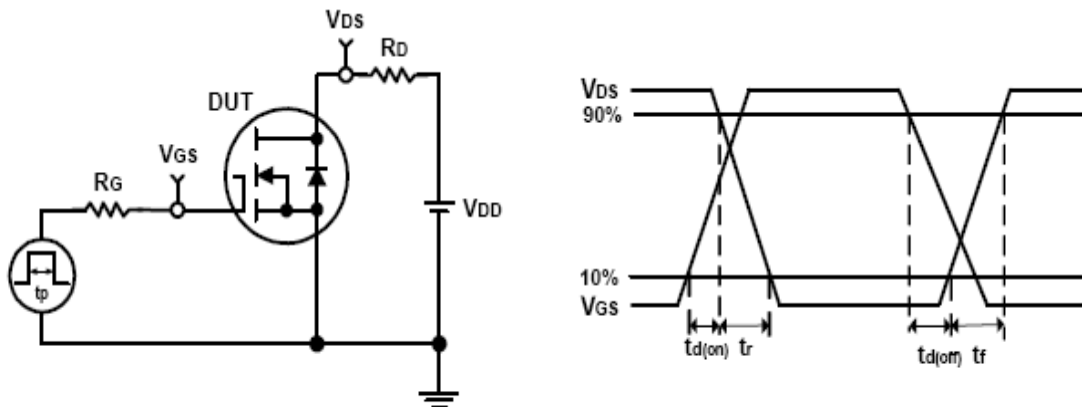

Package Information

TO252

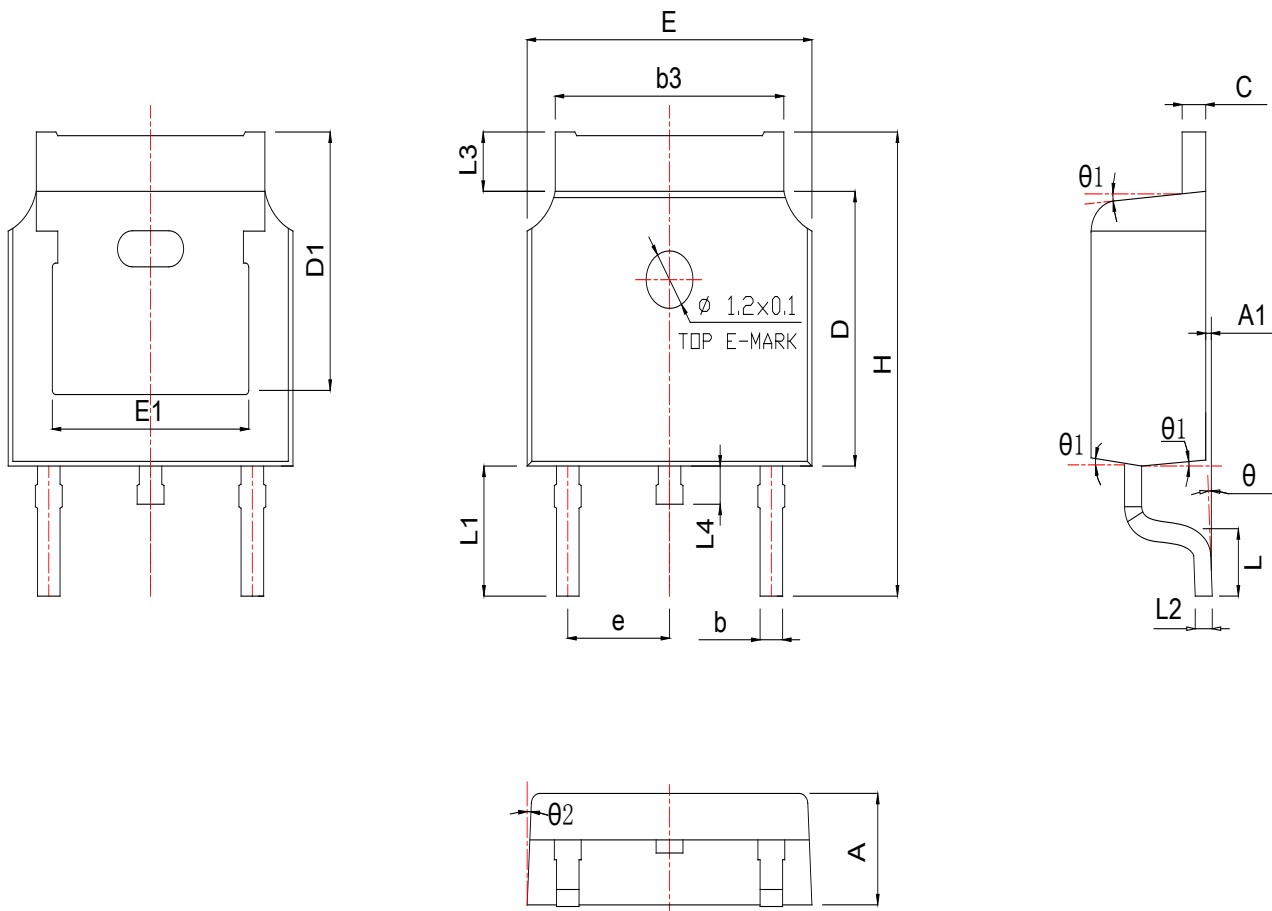

SYMBOL	MM			INCH		
	MIN	NOM	MAX	MIN	NOM	MAX
A	2.200	2.290	2.380	0.087	0.090	0.094
A1	0.000		0.100	0.000		0.004
b	0.720	0.785	0.850	0.028	0.031	0.033
b3	5.230	5.345	5.460	0.206	0.210	0.215
c	0.470	0.525	0.580	0.019	0.021	0.023
D	6.000	6.100	6.200	0.236	0.240	0.244
D1		5.30 REF			0.20 REF	
E	6.500	6.600	6.700	0.256	0.260	0.264
E1	4.700	4.810	4.920	0.185	0.189	0.194
e	2.28 REF			0.09 REF		
H	9.900	10.100	10.300	0.390	0.398	0.406
L	1.400	1.550	1.700	0.055	0.061	0.067
L1		2.743 REF			0.108 REF	
L2	0.510 BSC			0.020 BSC		
L3	0.900	1.075	1.250	0.035	0.042	0.049
L4	0.600	0.800	1.000	0.024	0.031	0.039
θ	0°		8°	0°		8°
θ 1	5°	7°	9°	5°	7°	9°
θ 2	5°	7°	9°	5°	7°	9°

Customer Service**Worldwide Sales and Service:**

Sales@ruichips.com

Technical Support:

Technical@ruichips.com

Investor Relations Contacts:

Investor@ruichips.com

Marcom Contact:

Marcom@ruichips.com

Editorial Contact:

Editorial@ruichips.com

HR Contact:

HR@ruichips.com

Legal Contact:

Legal@ruichips.com

Shen Zhen RUICHIPS Semiconductor CO., LTDRoom 501, the 5floor An Tong Industrial Building,
NO.207 Mei Hua Road Fu Tian Area Shen Zhen City, CHINA**TEL:** (86-755) 8311-5334**FAX:** (86-755) 8311-4278**E-mail:** Sales-SZ@ruichips.com