

### Features

- 30V/80A,  
 $R_{DS(ON)} = 2.3m\Omega(Typ.) @ V_{GS} = 10V$   
 $R_{DS(ON)} = 3m\Omega(Typ.) @ V_{GS} = 4.5V$
- Super High Dense Cell Design
- Reliable and Rugged
- 100% avalanche tested
- Lead Free and Green Devices Available (RoHS Compliant)

### Applications

- DC/DC Conversion
- Switching Application

### Pin Description

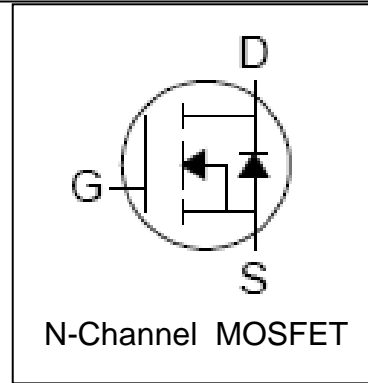
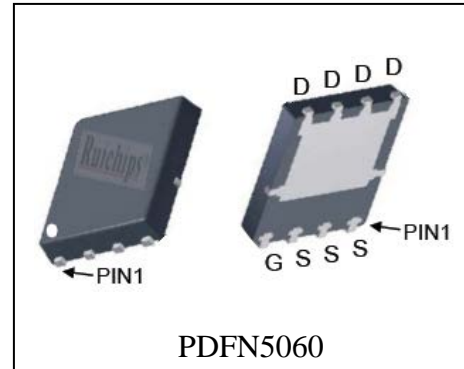

### Absolute Maximum Ratings

Symbol	Parameter	Rating	Unit
<b>Common Ratings</b> ( $T_C = 25^\circ C$ Unless Otherwise Noted)			
$V_{DSS}$	Drain-Source Voltage	30	V
$V_{GSS}$	Gate-Source Voltage	$\pm 20$	
$T_J$	Maximum Junction Temperature	150	$^\circ C$
$T_{STG}$	Storage Temperature Range	-55 to 150	$^\circ C$
$I_S$	Diode Continuous Forward Current	$T_C = 25^\circ C$ 50	A
<b>Mounted on Large Heat Sink</b>			
$I_{DP}$	300 $\mu s$ Pulse Drain Current Tested	$T_C = 25^\circ C$ 320 <sup>②</sup>	A
$I_D$	Continuous Drain Current ( $V_{GS} = 10V$ )	$T_C = 25^\circ C$ 80 <sup>①</sup>	A
		$T_C = 100^\circ C$ 64 <sup>①</sup>	
		$T_A = 25^\circ C$ 26 <sup>③</sup>	
		$T_A = 70^\circ C$ 21 <sup>③</sup>	
$P_D$	Maximum Power Dissipation	$T_C = 25^\circ C$ 62.5	W
		$T_C = 100^\circ C$ 25	
		$T_A = 25^\circ C$ 4.2 <sup>③</sup>	
		$T_A = 70^\circ C$ 2.7 <sup>③</sup>	

<b>Mounted on Large Heat Sink</b>			
$R_{\theta JC}$	Thermal Resistance-Junction to Case	2	$^{\circ}C/W$
$R_{\theta JA}^{(3)}$	Thermal Resistance-Junction to Ambient	30	$^{\circ}C/W$
<b>Drain-Source Avalanche Ratings</b>			
$E_{AS}^{(4)}$	Avalanche Energy, Single Pulsed	272	mJ

**Electrical Characteristics** ( $T_C=25^{\circ}C$  Unless Otherwise Noted)

Symbol	Parameter	Test Condition	RU3080M			Unit
			Min.	Typ.	Max.	
<b>Static Characteristics</b>						
$BV_{DSS}$	Drain-Source Breakdown Voltage	$V_{GS}=0V, I_{DS}=250\mu A$	30			V
$I_{DSS}$	Zero Gate Voltage Drain Current	$V_{DS}=30V, V_{GS}=0V$ $T_J=85^{\circ}C$			1 30	$\mu A$
$V_{GS(th)}$	Gate Threshold Voltage	$V_{DS}=V_{GS}, I_{DS}=250\mu A$	1	-	2.5	V
$I_{GSS}$	Gate Leakage Current	$V_{GS}=\pm 20V, V_{DS}=0V$			$\pm 100$	nA
$R_{DS(on)}^{(5)}$	Drain-Source On-state Resistance	$V_{GS}=10V, I_{DS}=20A$		2.3	3	$m\Omega$
		$V_{GS}=4.5V, I_{DS}=20A$		3	6	$m\Omega$
<b>Diode Characteristics</b>						
$V_{SD}^{(5)}$	Diode Forward Voltage	$I_{SD}=20A, V_{GS}=0V$			1.2	V
$t_{rr}$	Reverse Recovery Time	$I_{SD}=20A, dI_{SD}/dt=100A/\mu s$		33		ns
$Q_{rr}$	Reverse Recovery Charge			42		nC
<b>Dynamic Characteristics</b> <sup>(6)</sup>						
$R_G$	Gate Resistance	$V_{GS}=0V, V_{DS}=0V, F=1MHz$		1.4		$\Omega$
$C_{iss}$	Input Capacitance	$V_{GS}=0V,$ $V_{DS}=15V,$ Frequency=1.0MHz		3250		pF
$C_{oss}$	Output Capacitance			300		
$C_{rss}$	Reverse Transfer Capacitance			105		
$t_{d(ON)}$	Turn-on Delay Time	$V_{DD}=15V, R_L=0.75\Omega,$ $I_{DS}=20A, V_{GEN}=10V,$ $R_G=3\Omega$		15		ns
$t_r$	Turn-on Rise Time			27		
$t_{d(OFF)}$	Turn-off Delay Time			55		
$t_f$	Turn-off Fall Time			29		
<b>Gate Charge Characteristics</b> <sup>(6)</sup>						
$Q_g$	Total Gate Charge	$V_{DS}=24V, V_{GS}=10V,$ $I_{DS}=20A$		68		nC
$Q_{gs}$	Gate-Source Charge			16		
$Q_{gd}$	Gate-Drain Charge			21		

- Notes:
- ① Max current is limited to 50A by the package.
  - ② Pulse width limited by safe operating area.
  - ③ When mounted on 1 inch square copper board,  $t \leq 10\text{sec}$ .
  - ④ Limited by  $T_{J\text{max}}$ ,  $I_{AS} = 33\text{A}$ ,  $V_{DD} = 24\text{V}$ ,  $R_G = 50\Omega$ , Starting  $T_J = 25^\circ\text{C}$ .
  - ⑤ Pulse test ; Pulse width  $\leq 300\mu\text{s}$ , duty cycle  $\leq 2\%$ .
  - ⑥ Guaranteed by design, not subject to production testing.

## Ordering and Marking Information

Device	Marking	Package	Packaging	Quantity	Reel Size	Tape width
RU3080M	RU3080M	PDFN5060	Tape&Reel	3000	13''	12mm

**Typical Characteristics**

**Power Dissipation**

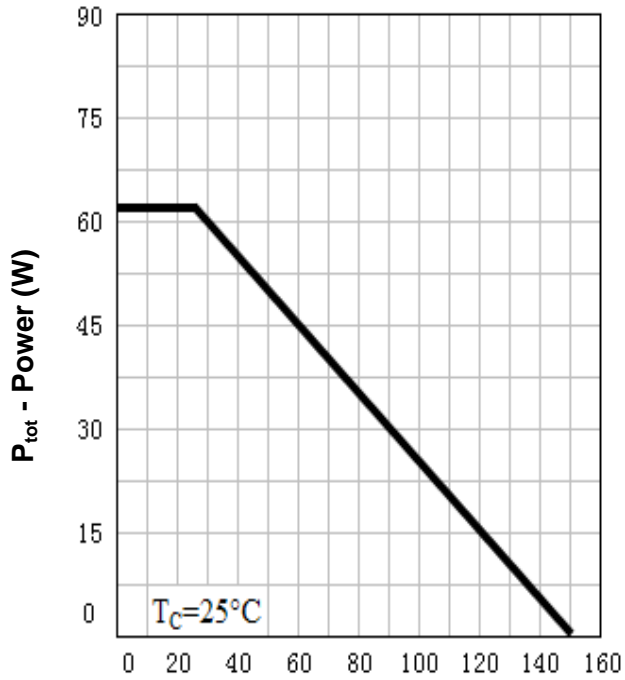

**T<sub>j</sub> - Junction Temperature (°C)**

**Drain Current**

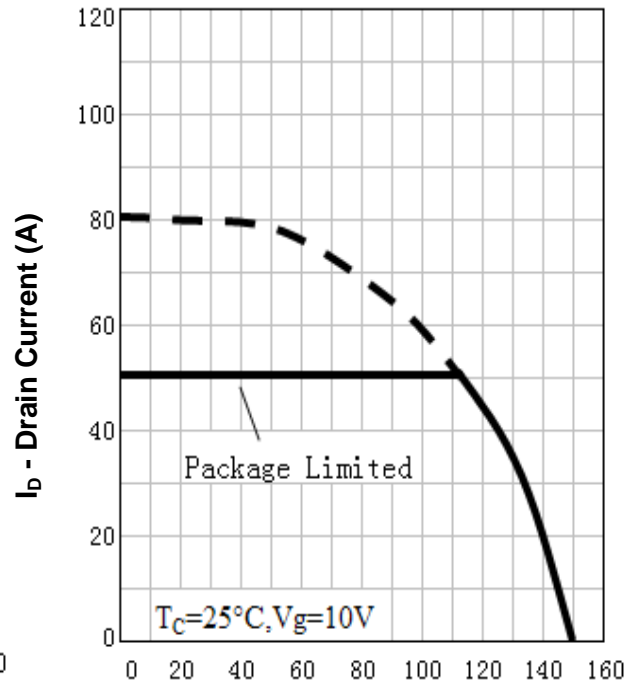

**T<sub>j</sub> - Junction Temperature (°C)**

**Safe Operation Area**

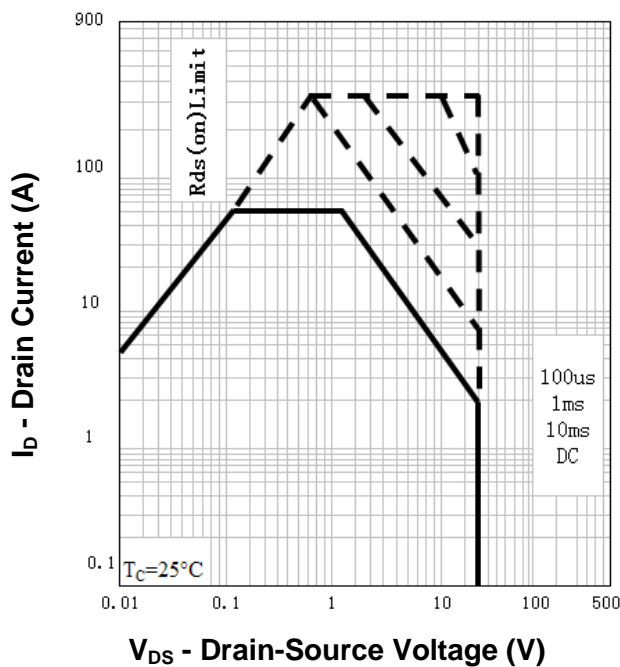

**V<sub>DS</sub> - Drain-Source Voltage (V)**

**Thermal Transient Impedance**

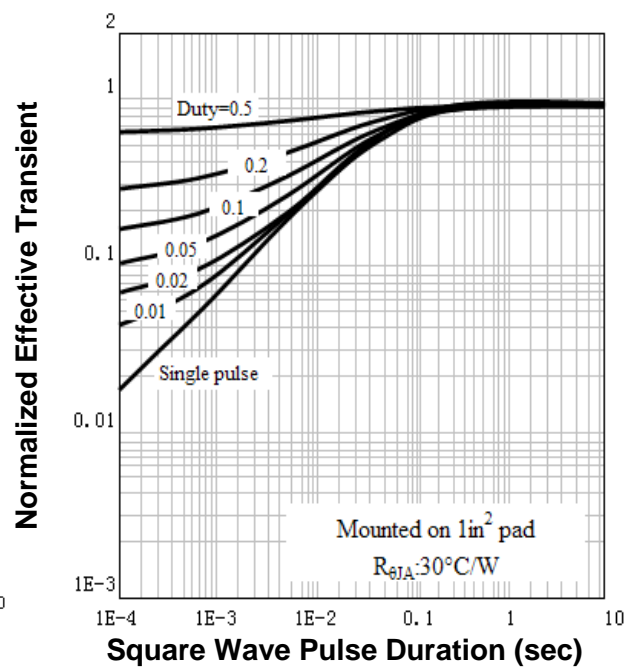

**Square Wave Pulse Duration (sec)**

**Typical Characteristics**

**Output Characteristics**

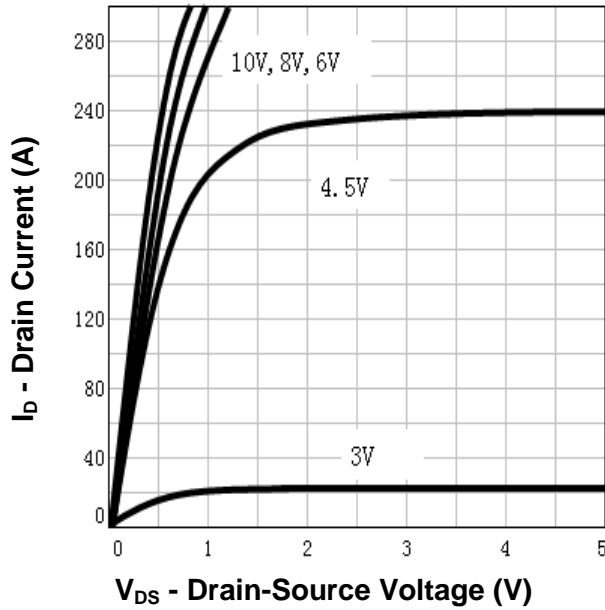

**Drain-Source On Resistance**

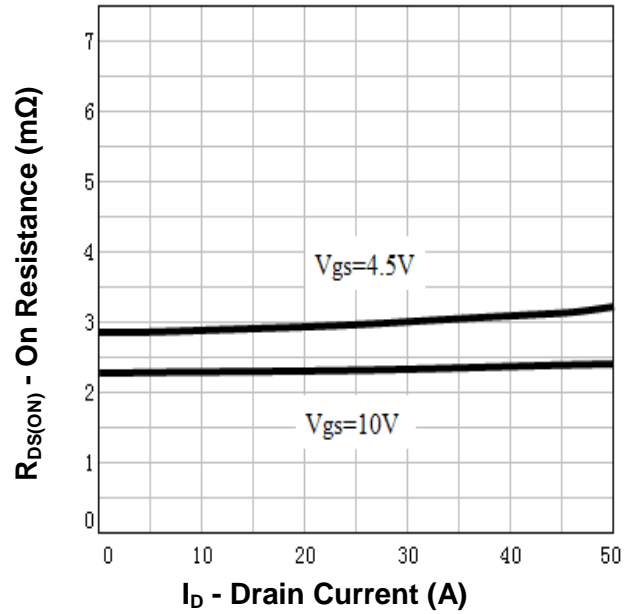

**Drain-Source On Resistance**

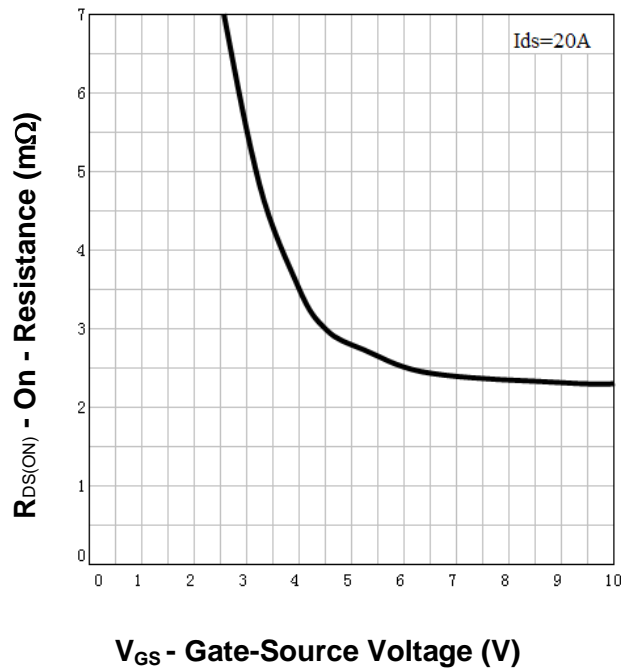

**Gate Threshold Voltage**

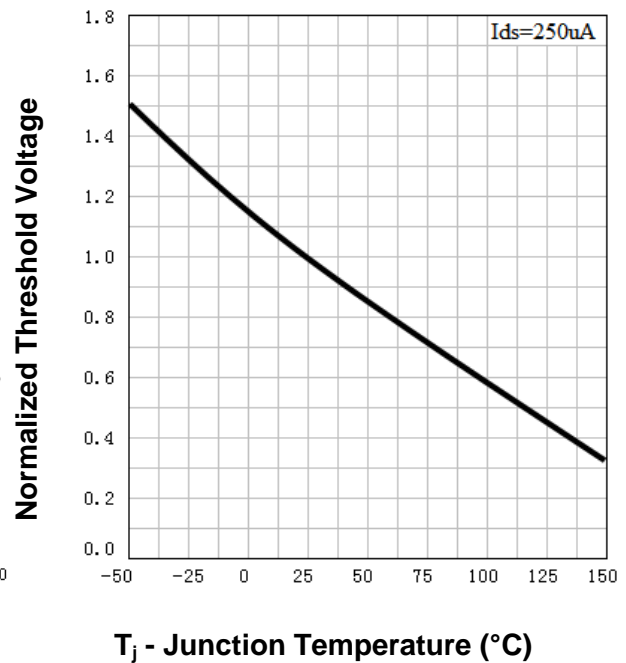

**Typical Characteristics**

**Drain-Source On Resistance**

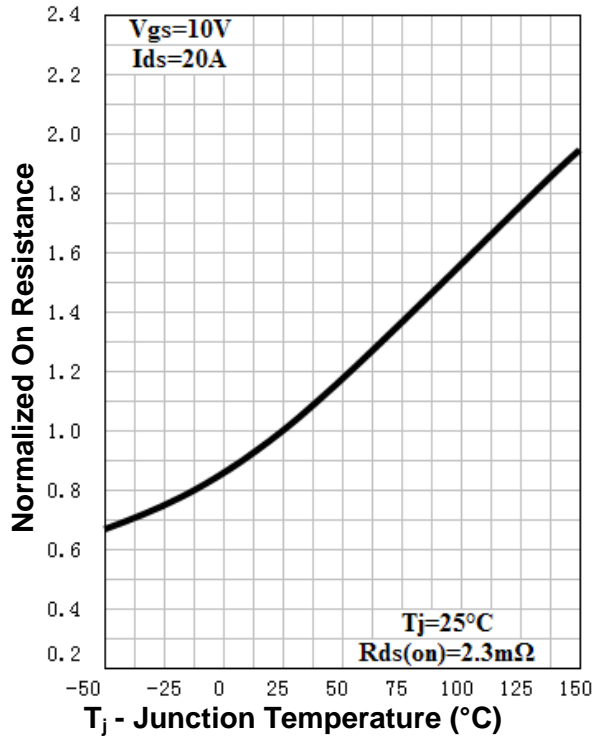

**Source-Drain Diode Forward**

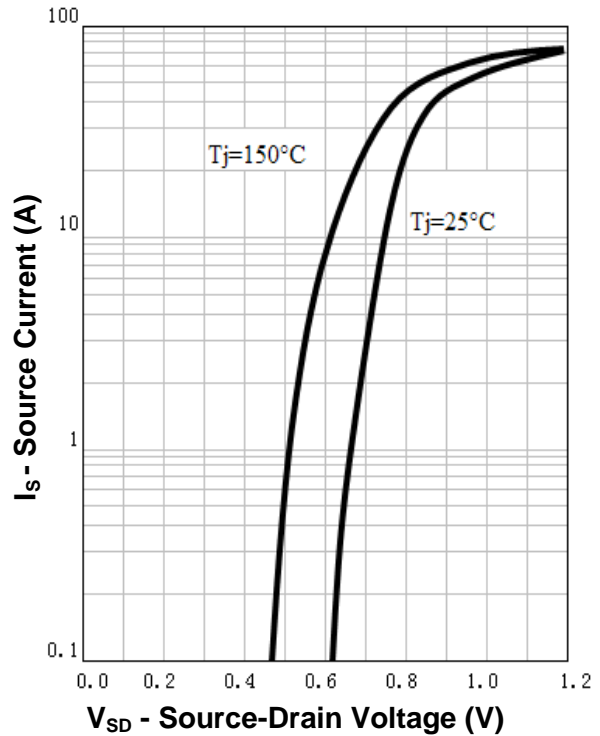

**Capacitance**

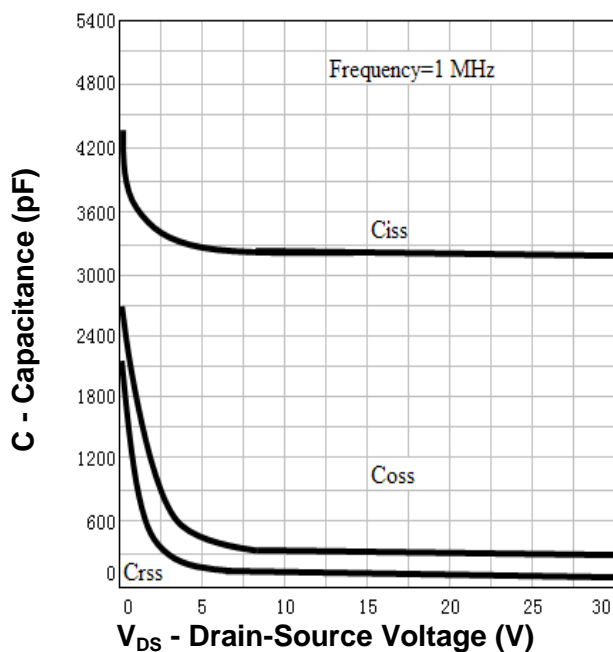

**Gate Charge**

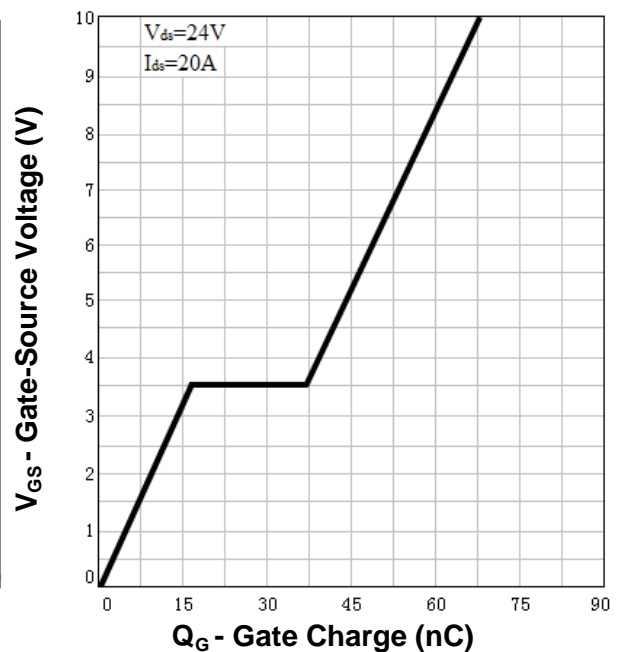

### Avalanche Test Circuit and Waveforms

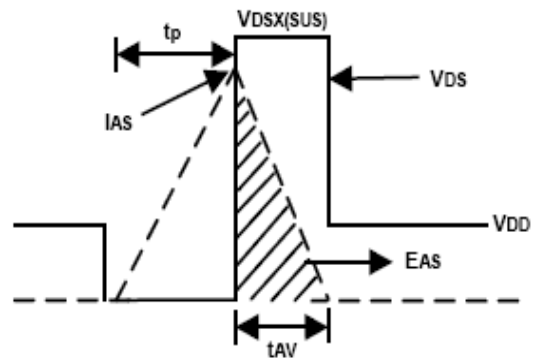
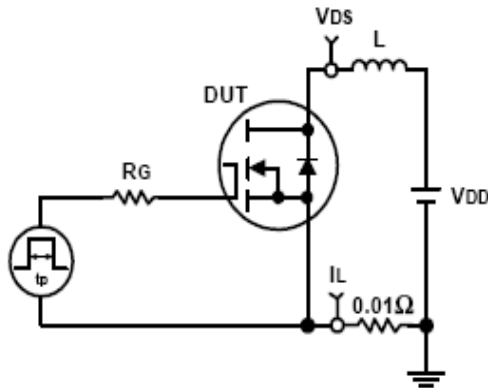

### Switching Time Test Circuit and Waveforms

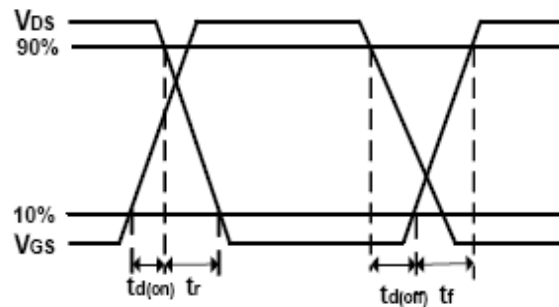
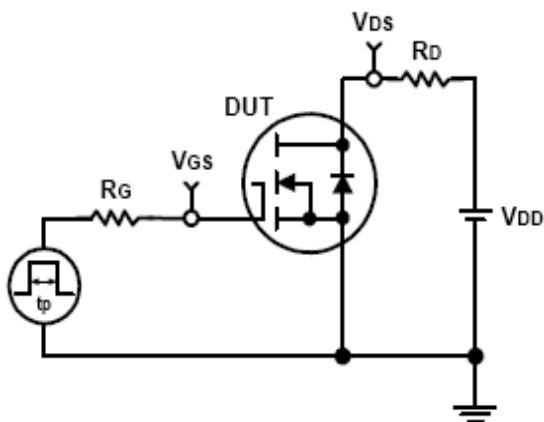

**Package Information**

**PDFN5060**

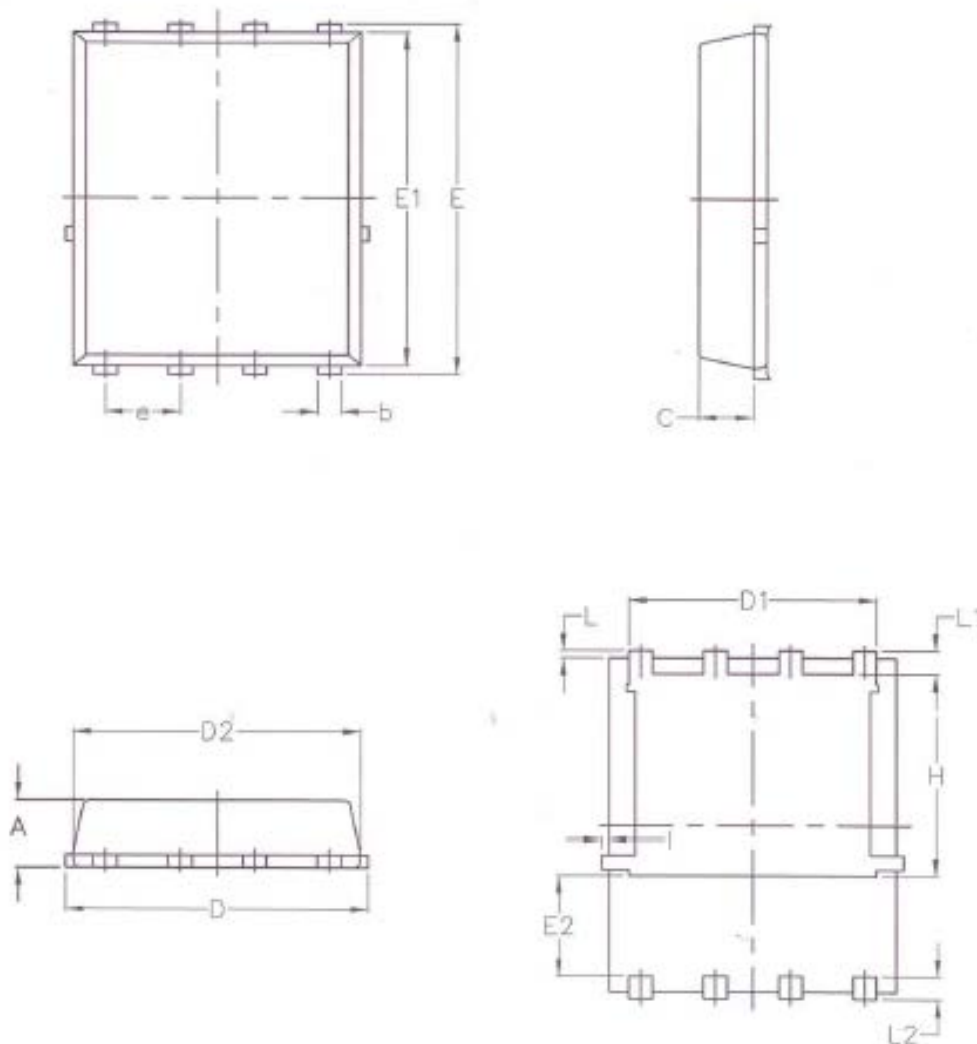

SYMBOL	MM		INCH		SYMBOL	MM		INCH	
	MIN	MAX	MIN	MAX		MIN	MAX	MIN	MAX
A	1.030	1.170	0.040	0.046	E2	1.600	-	0.063	-
b	0.340	0.480	0.013	0.019	e	1.270 BSC		0.050 BSC	
C	0.824	0.970	0.032	0.038	L	0.050	0.250	0.002	0.010
D	4.800	5.400	0.189	0.213	L1	0.380	0.500	0.015	0.020
D1	4.110	4.310	0.162	0.170	L2	0.380	0.500	0.015	0.020
D2	4.800	5.000	0.189	0.197	H	3.500	3.700	0.138	0.146
E	5.950	6.150	0.234	0.242	I	-	0.180	-	0.007
E1	5.650	5.850	0.222	0.230					

**ALL DIMENSIONS REFER TO JEDEC STANDARD  
DO NOT INCLUDE MOLD FLASH OR PROTRUSIONS**



## Customer Service

**Worldwide Sales and Service:**

Sales@ruichips.com

**Technical Support:**

Technical@ruichips.com

**Investor Relations Contacts:**

Investor@ruichips.com

**Marcom Contact:**

Marcom@ruichips.com

**Editorial Contact:**

Editorial@ruichips.com

**HR Contact:**

HR@ruichips.com

**Legal Contact:**

Legal@ruichips.com

**Shen Zhen RUICHIPS Semiconductor CO., LTD**

Room 501, the 5floor An Tong Industrial Building,  
NO.207 Mei Hua Road Fu Tian Area Shen Zhen City, CHINA

**TEL:** (86-755) 8311-5334

**FAX:** (86-755) 8311-4278

**E-mail:** Sales-SZ@ruichips.com