

Features

- 70V/80A,
 $R_{DS(ON)}=6.5m\Omega$ (Type) $V_{GS}=10V$ $I_{DS}=40A$
- Ultra Low On-Resistance
- Exceptional dv/dt capability
- Fast Switching and Fully Avalanche Rated
- 100% avalanche tested
- 175°C Operating Temperature
- Lead Free and Green Available

Applications

- Switching Application Systems
- Inverter Systems

Pin Description

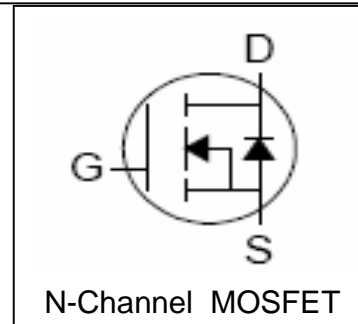
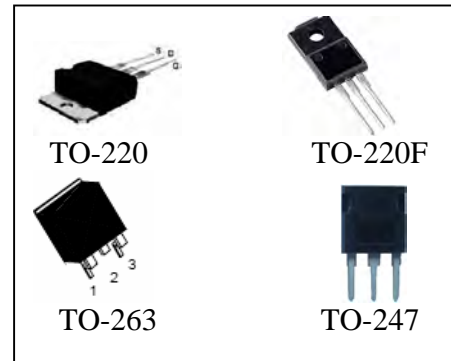

Absolute Maximum Ratings

Symbol	Parameter	Rating	Unit
Common Ratings ($T_A=25^\circ C$ Unless Otherwise Noted)			
V_{DSS}	Drain-Source Voltage	70	V
V_{GSS}	Gate-Source Voltage	± 25	
T_J	Maximum Junction Temperature	175	$^\circ C$
T_{STG}	Storage Temperature Range	-55 to 175	$^\circ C$
I_S	Diode Continuous Forward Current	$T_C=25^\circ C$ 80	A
Mounted on Large Heat Sink			
I_{DP}	300 μs Pulse Drain Current Tested	$T_C=25^\circ C$ 320	A
I_D	Continuous Drain Current	$T_C=25^\circ C$ 80 ^①	A
		$T_C=100^\circ C$ 60	
P_D	Maximum Power Dissipation	$T_C=25^\circ C$ 150	W
		$T_C=100^\circ C$ 80	
$R_{\theta JC}$	Thermal Resistance-Junction to Case	1.4	$^\circ C/W$
Drain-Source Avalanche Ratings			
E_{AS}	Avalanche Energy, Single Pulsed	150	mJ

Electrical Characteristics ($T_A=25^{\circ}\text{C}$ Unless Otherwise Noted)

Symbol	Parameter	Test Condition	RU7088			Unit
			Min.	Typ.	Max.	
Static Characteristics						
BV_{DSS}	Drain-Source Breakdown Voltage	$V_{GS}=0V, I_{DS}=-250\mu A$	70			V
I_{DSS}	Zero Gate Voltage Drain Current	$V_{DS}=70V, V_{GS}=0V$ $T_J=85^{\circ}\text{C}$			1	μA
					30	
$V_{GS(th)}$	Gate Threshold Voltage	$V_{DS}=V_{GS}, I_{DS}=-250\mu A$	2	3	4	V
I_{GSS}	Gate Leakage Current	$V_{GS}=\pm 25V, V_{DS}=0V$			± 100	nA
$R_{DS(ON)}^{(2)}$	Drain-Source On-state Resistance	$V_{GS}=10V, I_{DS}=40A$		6.5	9	m Ω
Diode Characteristics						
$V_{SD}^{(2)}$	Diode Forward Voltage	$I_{SD}=20A, V_{GS}=0V$		0.81	1.2	V
t_{rr}	Reverse Recovery Time	$I_{SD}=40A, dI_{SD}/dt=100A/\mu s$		50		ns
Q_{rr}	Reverse Recovery Charge			95		nC
Dynamic Characteristics ⁽³⁾						
R_G	Gate Resistance	$V_{GS}=0V, V_{DS}=0V, F=1\text{MHz}$		1.4		Ω
C_{iss}	Input Capacitance	$V_{GS}=0V,$ $V_{DS}=30V,$ Frequency=1.0MHz		3100		pF
C_{oss}	Output Capacitance			440		
C_{rss}	Reverse Transfer Capacitance			260		
$t_{d(ON)}$	Turn-on Delay Time		$V_{DD}=30V, R_L=30\Omega,$ $I_{DS}=1A, V_{GEN}=10V,$ $R_G=8\Omega$		18	32
t_r	Turn-on Rise Time			15	28	
$t_{d(OFF)}$	Turn-off Delay Time			63	110	
t_f	Turn-off Fall Time			33	60	
Gate Charge Characteristics ⁽³⁾						
Q_g	Total Gate Charge	$V_{DS}=30V, V_{GS}=10V,$ $I_{DS}=40A$		75	108	nC
Q_{gs}	Gate-Source Charge			14		
Q_{gd}	Gate-Drain Charge			25		

- Notes: ① Current limited by wire bond.
 ② Pulse test ; Pulse width $\leq 300\mu s$, duty cycle $\leq 2\%$.
 ③ Guaranteed by design, not subject to production testing.

Typical Characteristics

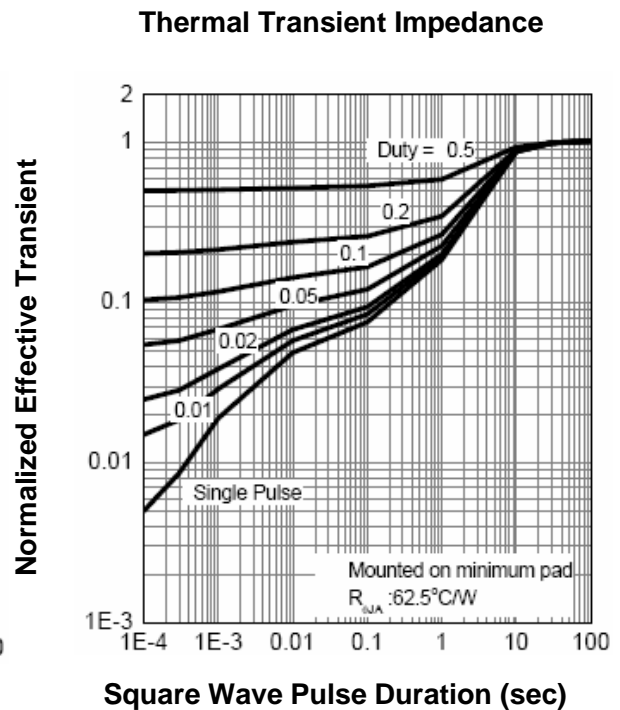
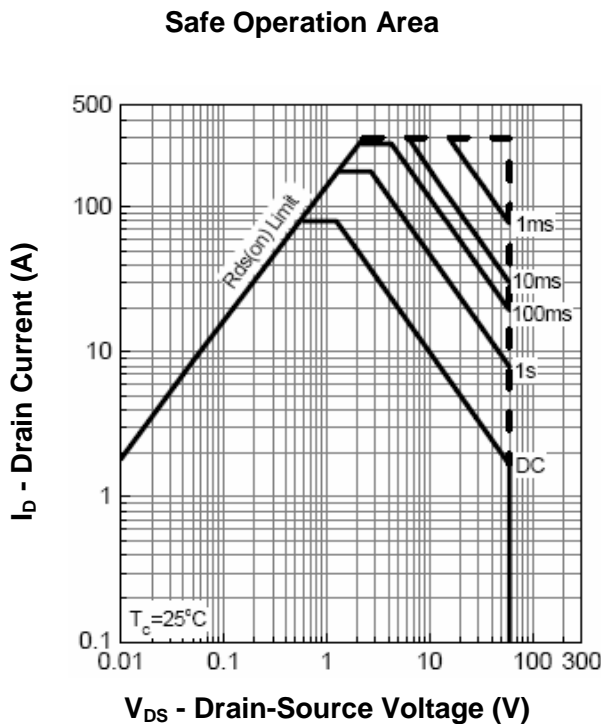
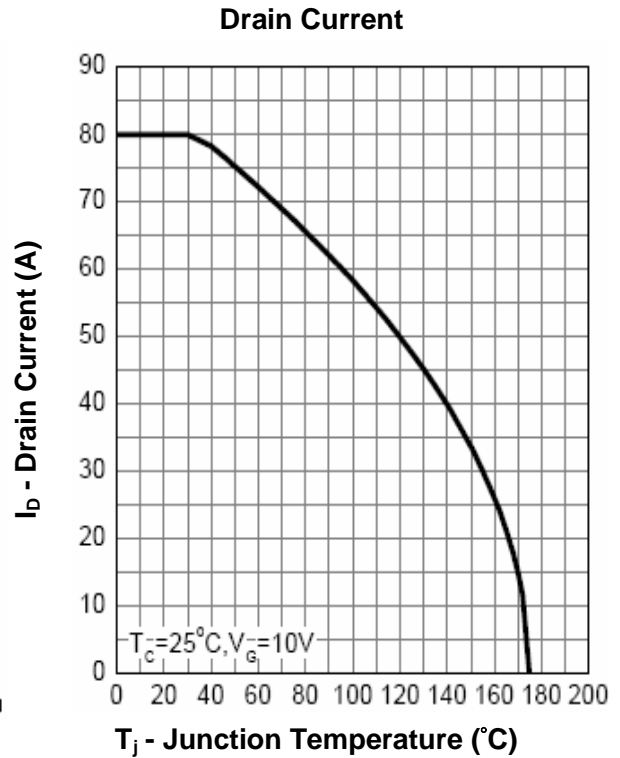
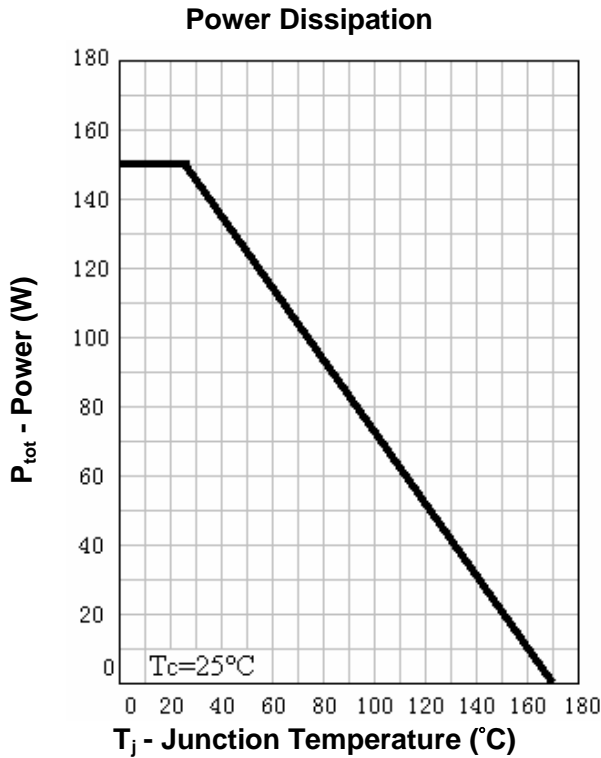

Typical Characteristics

Output Characteristics

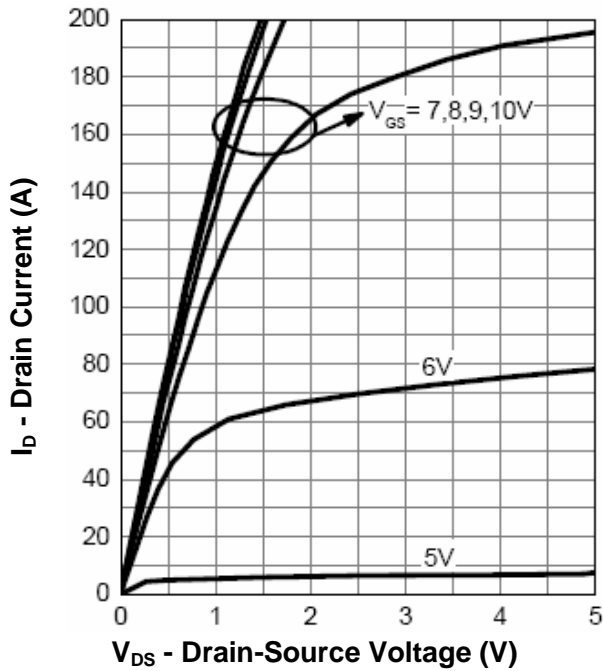

Drain-Source On Resistance

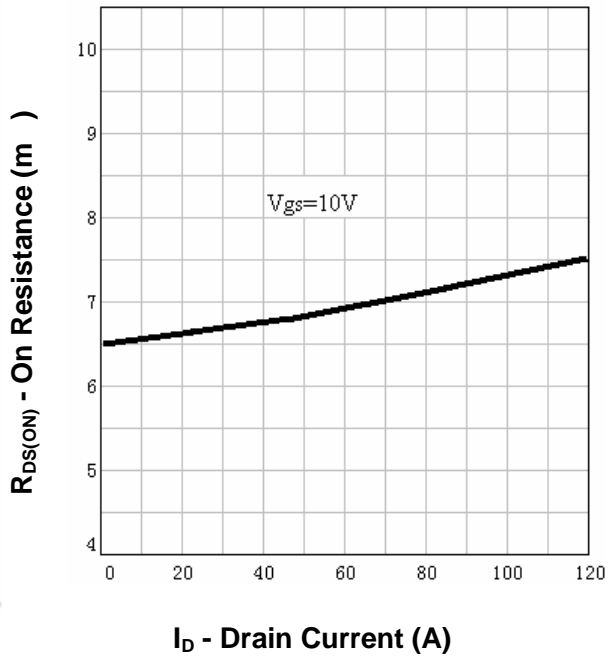

Drain-Source On Resistance

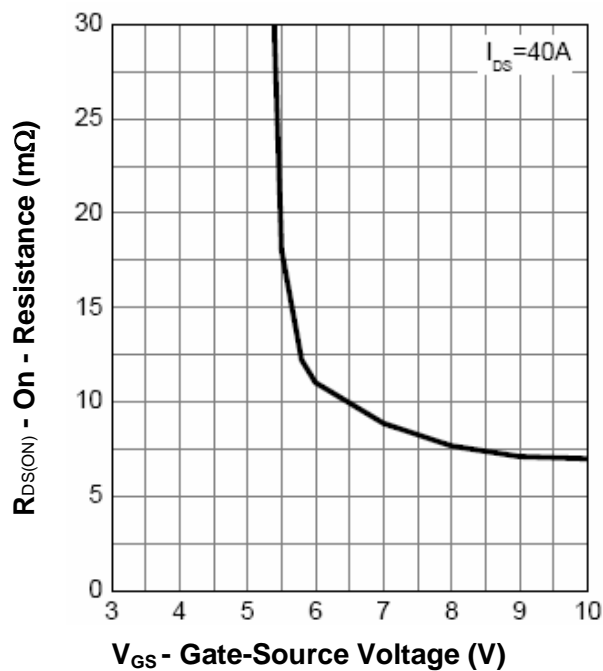

Gate Threshold Voltage

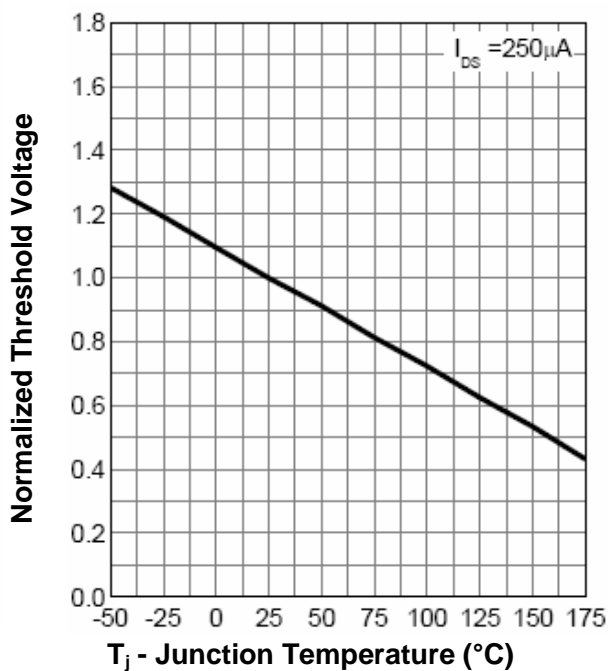

Typical Characteristics

Drain-Source On Resistance

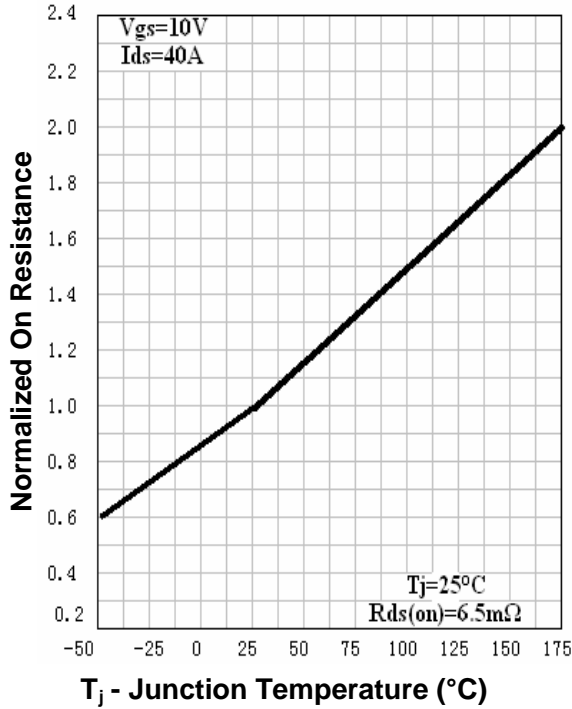

Source-Drain Diode Forward

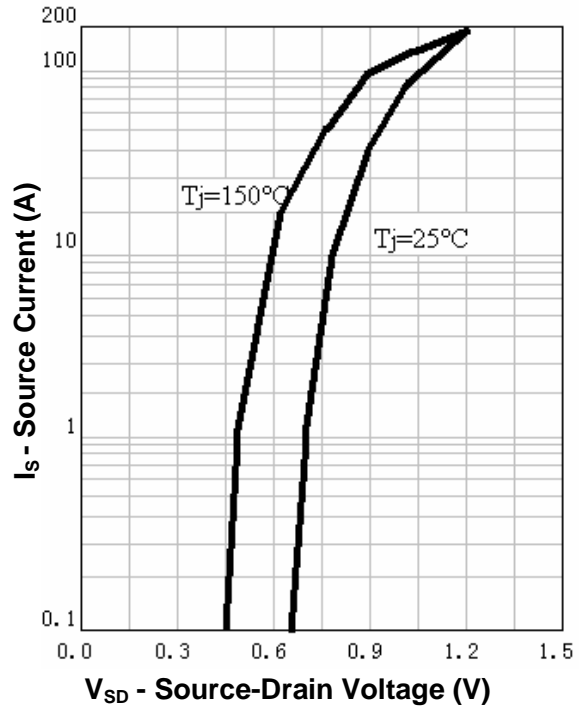

Capacitance

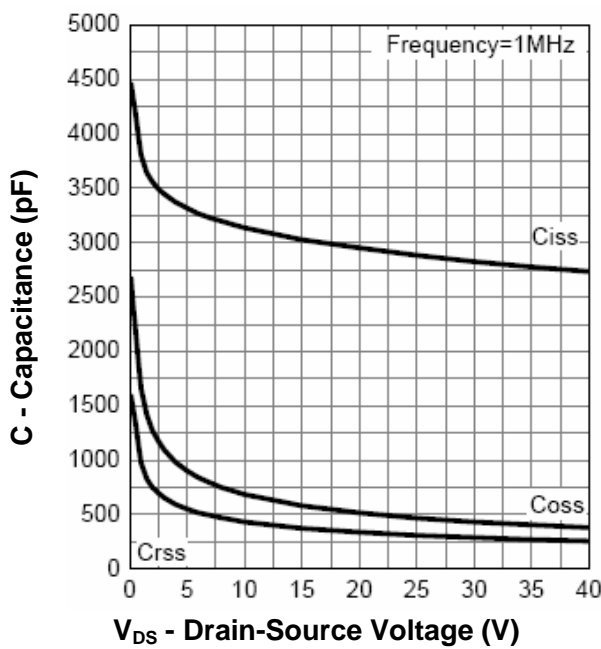

Gate Charge

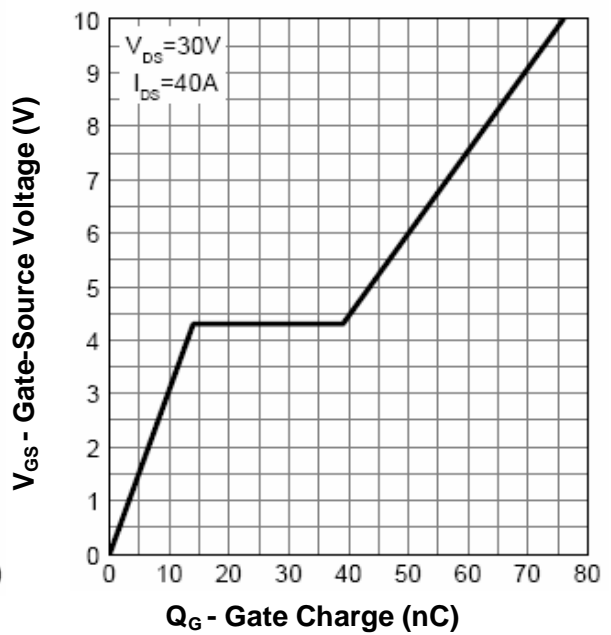

Avalanche Test Circuit and Waveforms

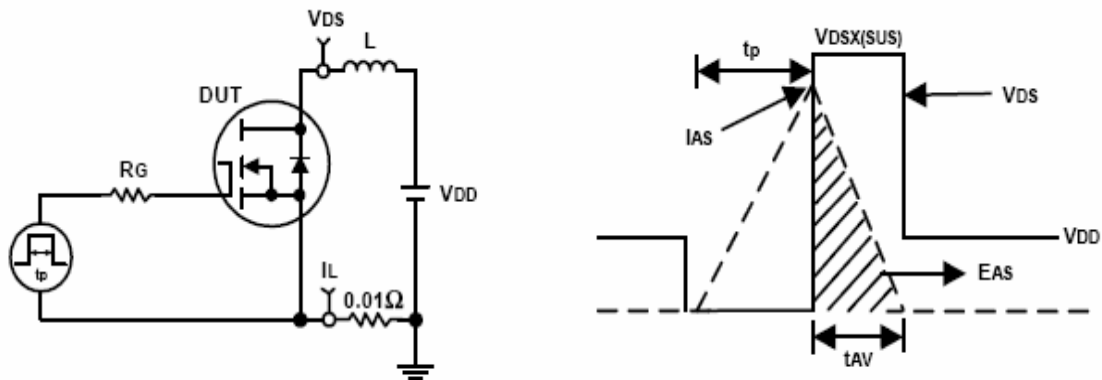

Switching Time Test Circuit and Waveforms

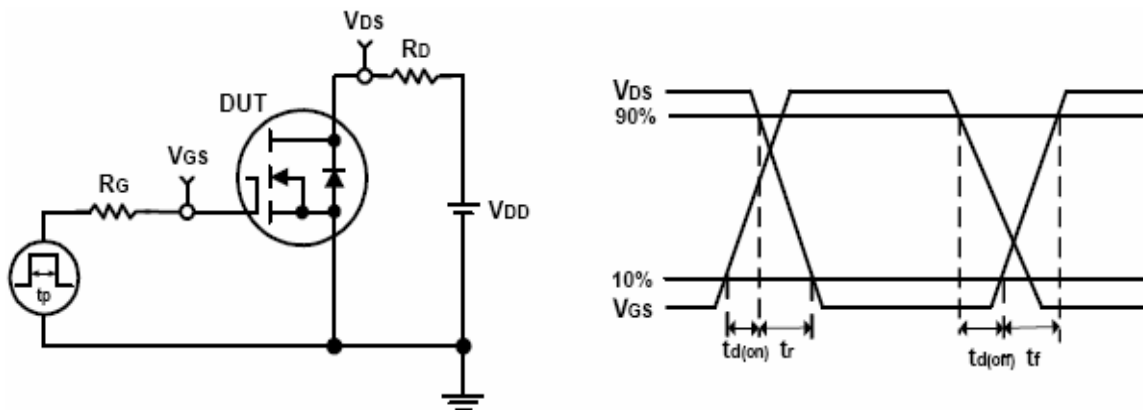

Ordering and Marking Information**RU7088****Package (Available)**

R : TO-220; S: TO-263 ; P: TO-220F

Operating Temperature Range

C : -55 to 175 °C

Assembly Material

G : Green & Lead Free

Packaging

T : TUBE

TR : Tape & Reel

Package Information

TO-220FB-3L

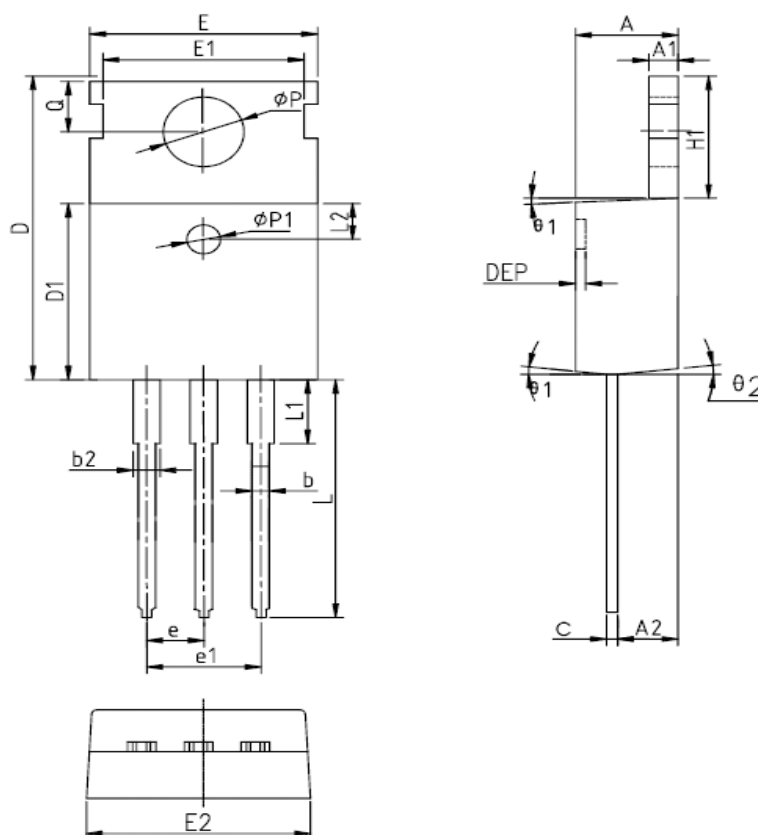

SYMBOL	MM			INCH			SYMBOL	MM			INCH		
	MIN	NOM	MAX	MIN	NOM	MAX		MIN	NOM	MAX	MIN	NOM	MAX
A	4.40	4.57	4.70	0.173	0.180	0.185	$\phi p1$	1.40	1.50	1.60	0.055	0.059	0.063
A1	1.27	1.30	1.33	0.050	0.051	0.052	e	2.54BSC			0.1BSC		
A2	2.35	2.40	2.50	0.093	0.094	0.098	e1	5.08BSC			0.2BSC		
b	0.77	-	0.90	0.030	-	0.035	H1	6.40	6.50	6.60	0.252	0.256	0.260
b2	1.23	-	1.36	0.048	-	0.054	L	12.75	-	13.17	0.502	-	0.519
C	0.48	0.50	0.52	0.019	0.020	0.021	L1	-	-	3.95	-	-	0.156
D	15.40	15.60	15.80	0.606	0.614	0.622	L2	2.50REF.			0.098REF.		
D1	9.00	9.10	9.20	0.354	0.358	0.362	ϕp	3.57	3.60	3.63	0.141	0.142	0.143
DEP	0.05	0.10	0.20	0.002	0.004	0.008	Q	2.73	2.80	2.87	0.107	0.110	0.113
E	9.70	9.90	10.10	0.382	0.389	0.398	$\theta 1$	5°	7°	9°	5°	7°	9°
E1	-	8.70	-	-	0.343	-	$\theta 2$	1°	3°	5°	1°	3°	5°
E2	9.80	10.00	10.20	0.386	0.394	0.401							

ALL DIMENSIONS REFER TO JEDEC STANDARD
DO NOT INCLUDE MOLD FLASH OR PROTRUSIONS

TO-263-2L

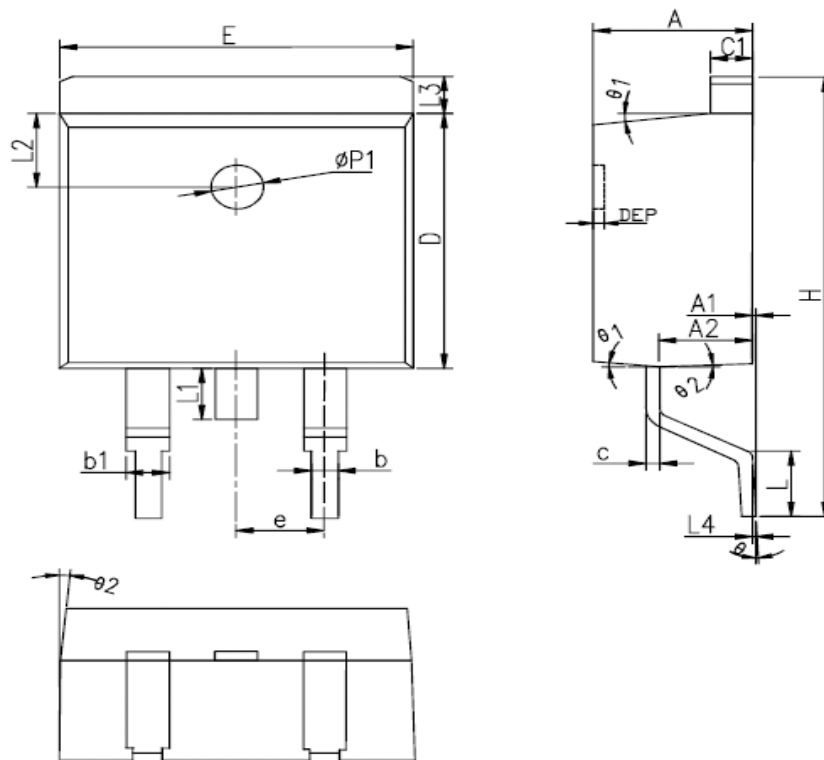

SYMBOL	MM			INCH			SYMBOL	MM			INCH		
	MIN	NOM	MAX	MIN	NOM	MAX		MIN	NOM	MAX	MIN	NOM	MAX
A	4.40	4.57	4.70	0.173	0.180	0.185	L	2.00	2.30	2.60	0.079	0.090	0.102
A1	0	0.10	0.25	0	0.004	0.010	L3	1.17	1.27	1.40	0.046	0.050	0.055
A2	2.59	2.69	2.79	0.102	0.106	0.110	L1	-	-	1.70	-	-	0.067
b	0.77	-	0.90	0.030	-	0.035	L4	0.25BSC			0.01BSC		
b1	1.23	-	1.36	0.048	-	0.052	L2	2.50REF.			0.098REF.		
c	0.34	-	0.47	0.013	-	0.019	θ	0°	-	8°	0°	-	8°
C1	1.22	-	1.32	0.048	-	0.052	θ 1	5°	7°	9°	5°	7°	9°
D	8.60	8.70	8.80	0.338	0.343	0.346	θ 2	1°	3°	5°	1°	3°	5°
E	10.00	10.16	10.26	0.394	0.4	0.404	DEP	0.05	0.10	0.20	0.002	0.004	0.008
e	2.54BSC			0.1BSC			Øp1	1.40	1.50	1.60	0.055	0.059	0.063
H	14.70	15.10	15.50	0.579	0.594	0.610							

**ALL DIMENSIONS REFER TO JEDEC STANDARD
DO NOT INCLUDE MOLD FLASH OR PROTRUSIONS**

TO-220F-3L

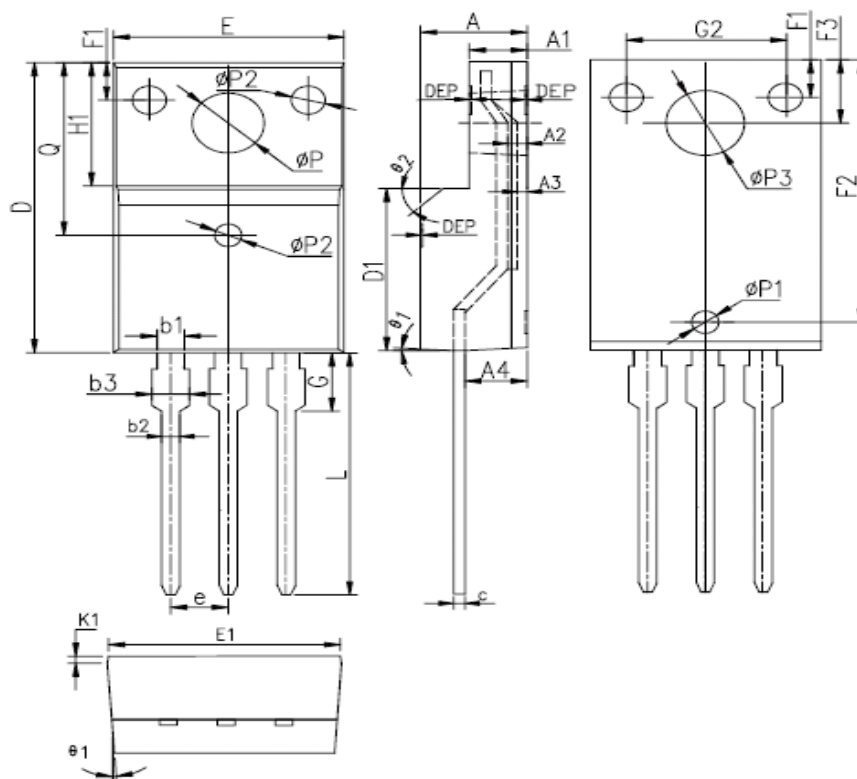

SYMBOL	MM			INCH			SYMBOL	MM			INCH		
	MIN	NOM	MAX	MIN	NOM	MAX		MIN	NOM	MAX	MIN	NOM	MAX
E	9.96	10.16	10.36	0.392	0.400	0.408	$\phi p3$	-	3.450	-	-	0.136	-
A	4.50	4.70	4.90	0.177	0.185	0.193	$\theta 1$	5°	7°	9°	5°	7°	9°
A1	2.34	2.54	2.74	0.092	0.100	0.108	$\theta 2$	-	45°	-	-	45°	-
A2	0.95	1.05	1.15	0.037	0.041	0.045	DEP	0.05	0.10	0.15	0.002	0.004	0.006
A3	0.42	0.52	0.62	0.017	0.020	0.024	F1	1.90	2.00	2.10	0.075	0.079	0.083
A4	2.65	2.75	2.85	0.104	0.108	0.112	F2	13.61	13.81	14.01	0.536	0.544	0.552
c	-	0.50	-	-	0.020	-	F3	3.20	3.30	3.40	0.126	0.130	0.134
D	15.67	15.87	16.07	0.617	0.625	0.633	G	3.25	3.45	3.65	0.128	0.136	0.144
Q	8.80	9.00	9.20	0.346	0.354	0.362	G1	5.90	6.00	6.10	0.232	0.236	0.240
H1	6.48	6.68	6.88	0.255	0.263	0.271	G2	6.90	7.00	7.10	0.272	0.276	0.280
e	2.54BSC			0.1BSC			b1	1.17	1.20	1.24	0.046	0.047	0.048
ϕp	-	3.183	-	-	0.125	-	b2	0.77	0.8	0.85	0.030	0.031	0.033
L	12.78	12.98	13.18	0.503	0.511	0.519	b3	1.10	1.30	1.50	0.043	0.051	0.059
D1	8.99	9.19	9.39	0.354	0.362	0.370	E1	9.8	10.00	10.20	0.386	0.394	0.412
$\phi p1$	1.40	1.50	1.60	0.055	0.059	0.063	K1	0.75	0.8	0.85	0.030	0.031	0.033
$\phi p2$	1.15	1.20	1.25	0.045	0.047	0.049							

**ALL DIMENSIONS REFER TO JEDEC STANDARD
DO NOT INCLUDE MOLD FLASH OR PROTRUSIONS**

Customer Service

Worldwide Sales and Service:

Sales@ruichips.com

Technical Support:

Technical@ruichips.com

Investor Relations Contacts:

Investor@ruichips.com

Marcom Contact:

Marcom@ruichips.com

Editorial Contact:

Editorial@ruichips.com

HR Contact:

HR@ruichips.com

Legal Contact:

Legal@ruichips.com

Shen Zhen RUICHIPS Semiconductor CO., LTD

Room 501, the 5floor An Tong Industrial Building,
NO.207 Mei Hua Road Fu Tian Area Shen Zhen City, CHINA

TEL: (86-755) 8311-5334

FAX: (86-755) 8311-4278

E-mail: Sales-SZ@ruichips.com