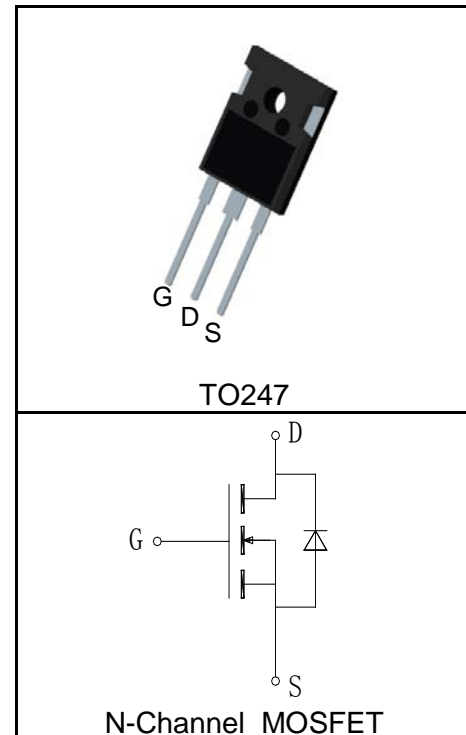

Features

- 75V/400A,
 $R_{DS(ON)} = 1.5m\Omega(Typ.)@V_{GS}=10V$
- Ultra Low On-Resistance
- Exceptional dv/dt capability
- Fast Switching and Fully Avalanche Rated
- 100% avalanche tested
- 175°C Operating Temperature
- Lead Free and Green Devices Available (RoHS Compliant)

Applications

- High Efficiency Synchronous Rectification in SMPS
- High Speed Power Switching
- Power Supply

Pin Description

Absolute Maximum Ratings

Symbol	Parameter	Rating	Unit
Common Ratings ($T_C=25^\circ C$ Unless Otherwise Noted)			
V_{DSS}	Drain-Source Voltage	75	V
V_{GSS}	Gate-Source Voltage	± 25	
T_J	Maximum Junction Temperature	175	$^\circ C$
T_{STG}	Storage Temperature Range	-55 to 175	$^\circ C$
I_S	Diode Continuous Forward Current	$T_C=25^\circ C$ 400	A
Mounted on Large Heat Sink			
$I_{DP}^{①}$	300 μs Pulse Drain Current Tested	$T_C=25^\circ C$ 1480	A
$I_D^{②}$	Continuous Drain Current($V_{GS}=10V$)	$T_C=25^\circ C$ 400	A
		$T_C=100^\circ C$ 283	
P_D	Maximum Power Dissipation	$T_C=25^\circ C$ 600	W
		$T_C=100^\circ C$ 300	
$R_{\theta JC}$	Thermal Resistance-Junction to Case	0.25	$^\circ C/W$
$R_{\theta JA}$	Thermal Resistance-Junction to Ambient	50	$^\circ C/W$
Drain-Source Avalanche Ratings			
$E_{AS}^{③}$	Avalanche Energy, Single Pulsed	1225	mJ

Electrical Characteristics ($T_C=25^{\circ}\text{C}$ Unless Otherwise Noted)

Symbol	Parameter	Test Condition	RU75400Q			Unit
			Min.	Typ.	Max.	
Static Characteristics						
BV_{DSS}	Drain-Source Breakdown Voltage	$V_{GS}=0V, I_{DS}=250\mu A$	75			V
I_{DSS}	Zero Gate Voltage Drain Current	$V_{DS}=75V, V_{GS}=0V$			1	μA
		$T_J=125^{\circ}\text{C}$			30	
$V_{GS(th)}$	Gate Threshold Voltage	$V_{DS}=V_{GS}, I_{DS}=250\mu A$	2	3	4	V
I_{GSS}	Gate Leakage Current	$V_{GS}=\pm 25V, V_{DS}=0V$			± 100	nA
$R_{DS(ON)}^{(4)}$	Drain-Source On-state Resistance	$V_{GS}=10V, I_{DS}=75A$		1.5	2	m Ω
Diode Characteristics						
$V_{SD}^{(4)}$	Diode Forward Voltage	$I_{SD}=75A, V_{GS}=0V$			1.2	V
t_{rr}	Reverse Recovery Time	$I_{SD}=75A, di_{SD}/dt=100A/\mu s$		150		ns
Q_{rr}	Reverse Recovery Charge			480		nC
Dynamic Characteristics ⁽⁵⁾						
R_G	Gate Resistance	$V_{GS}=0V, V_{DS}=0V, F=1\text{MHz}$		0.9		Ω
C_{iss}	Input Capacitance	$V_{GS}=0V,$ $V_{DS}=38V,$ Frequency=1.0MHz		13500		pF
C_{oss}	Output Capacitance			1440		
C_{riss}	Reverse Transfer Capacitance			650		
$t_{d(ON)}$	Turn-on Delay Time	$V_{DD}=20V, R_L=0.3\Omega,$ $I_{DS}=75A, V_{GEN}=10V,$ $R_G=4.7\Omega$		38		ns
t_r	Turn-on Rise Time			210		
$t_{d(OFF)}$	Turn-off Delay Time			165		
t_f	Turn-off Fall Time			280		
Gate Charge Characteristics ⁽⁵⁾						
Q_g	Total Gate Charge	$V_{DS}=60V, V_{GS}=10V,$ $I_{DS}=75A$		410		nC
Q_{gs}	Gate-Source Charge			80		
Q_{gd}	Gate-Drain Charge			110		

- Notes:
- ① Pulse width limited by safe operating area.
 - ② Calculated continuous current based on maximum allowable junction temperature. The package limitation current is 90A.
 - ③ Limited by T_{Jmax} , $I_{AS}=70A$, $V_{DD}=48V$, $R_G=50\Omega$, Starting $T_J=25^{\circ}\text{C}$.
 - ④ Pulse test; Pulse width $\leq 300\mu s$, duty cycle $\leq 2\%$.
 - ⑤ Guaranteed by design, not subject to production testing.

Ordering and Marking Information

Device	Marking	Package	Packaging	Quantity	Reel Size	Tape width
RU75400Q	RU75400Q	TO247	Tube	30	-	-

Typical Characteristics

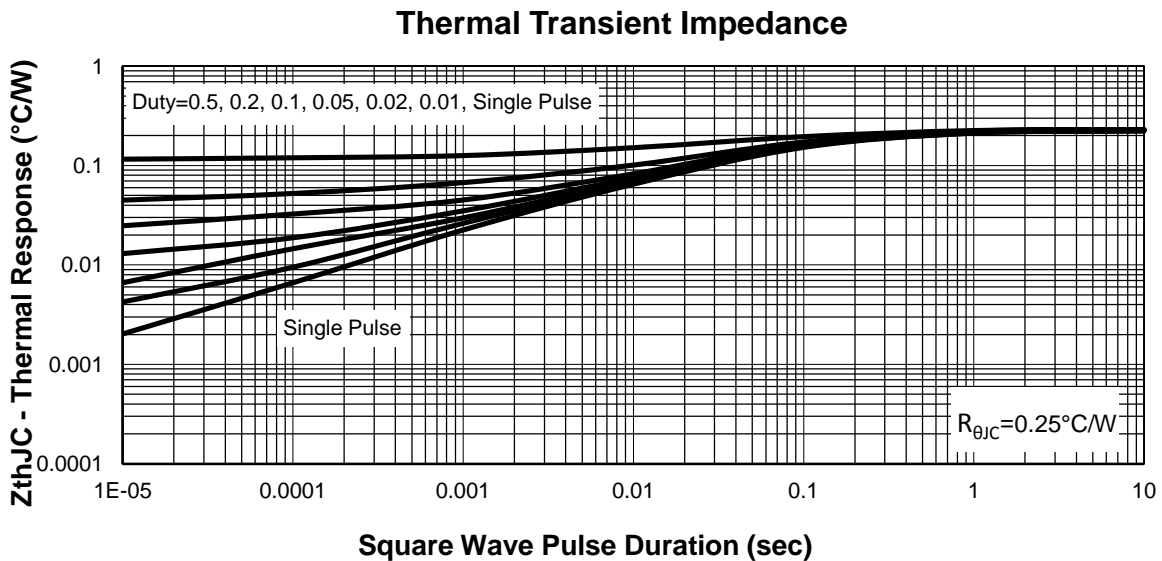
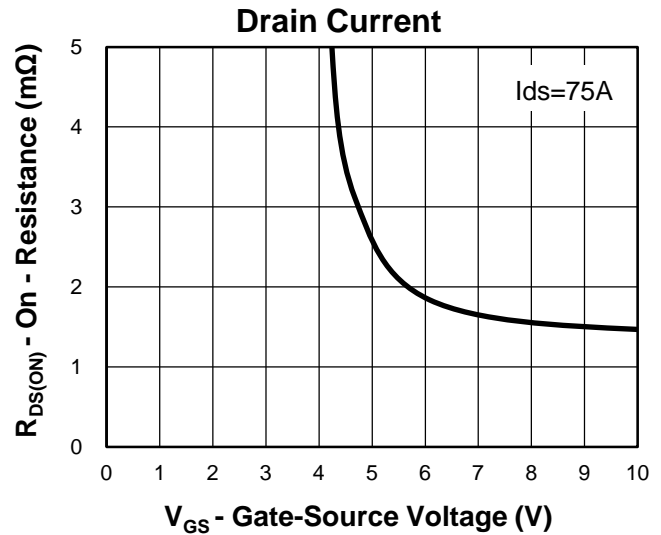
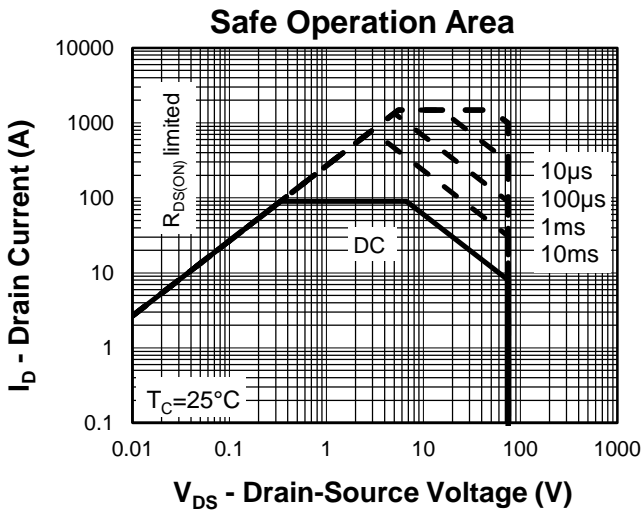
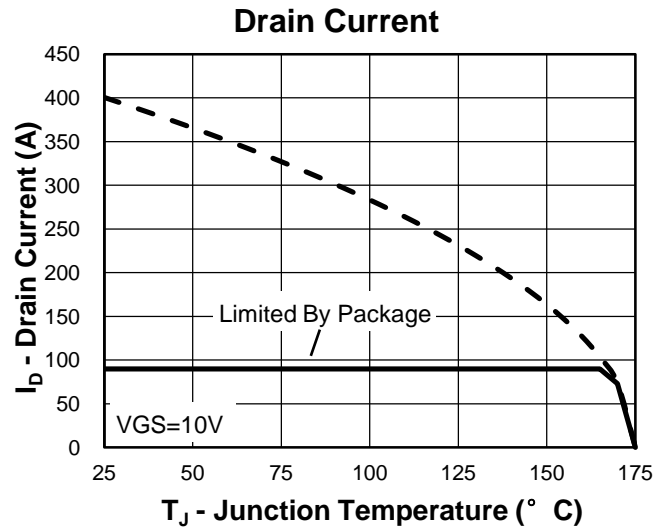
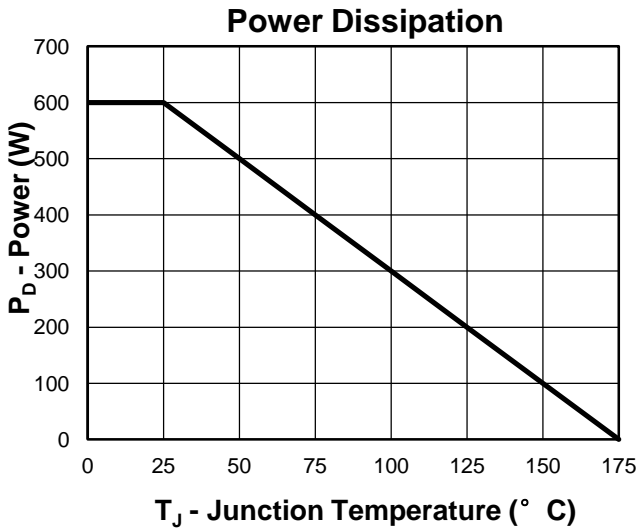

Typical Characteristics

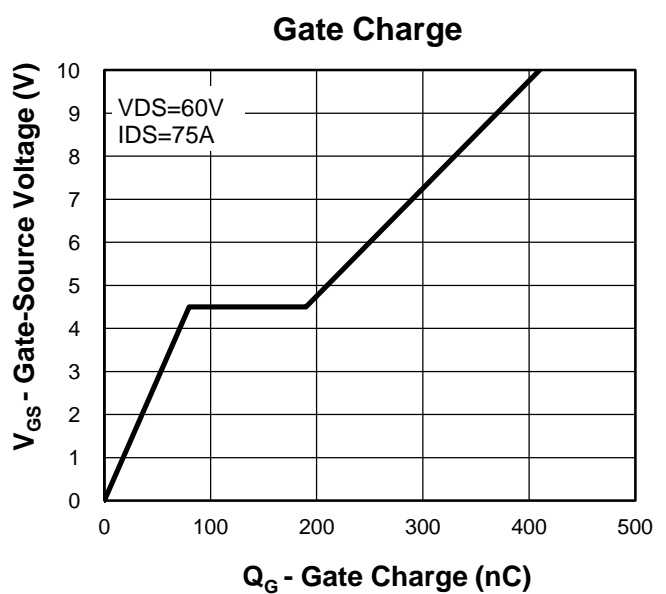
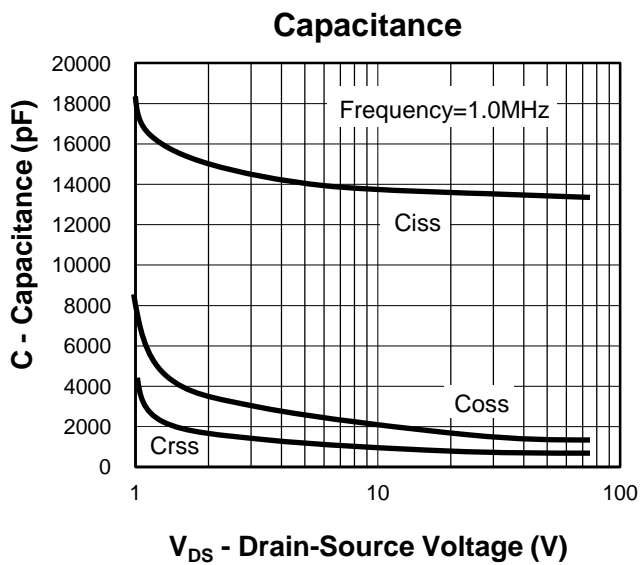
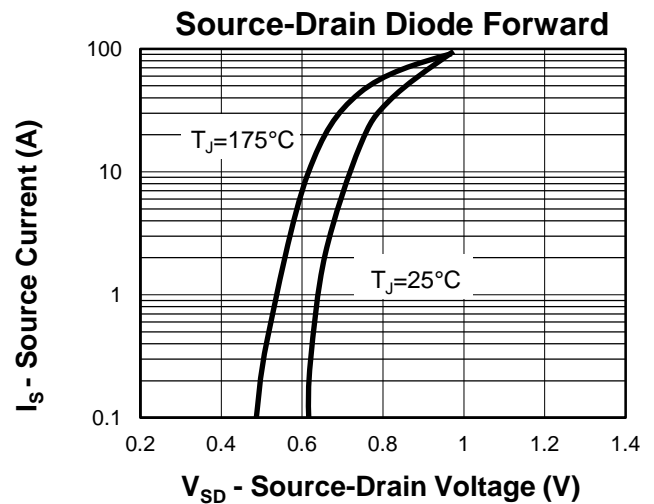
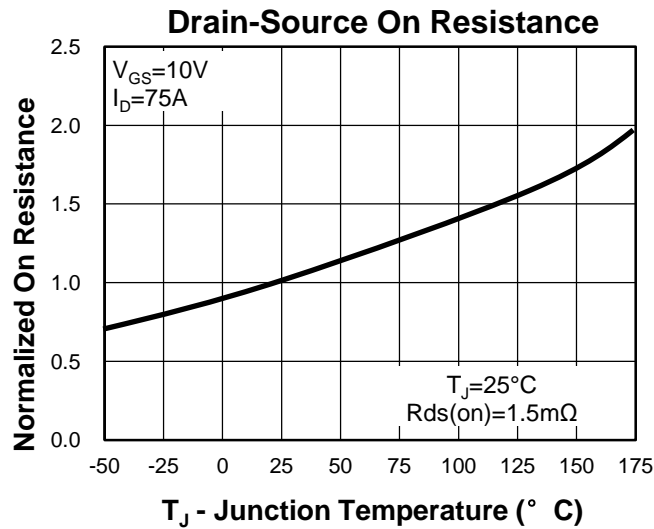
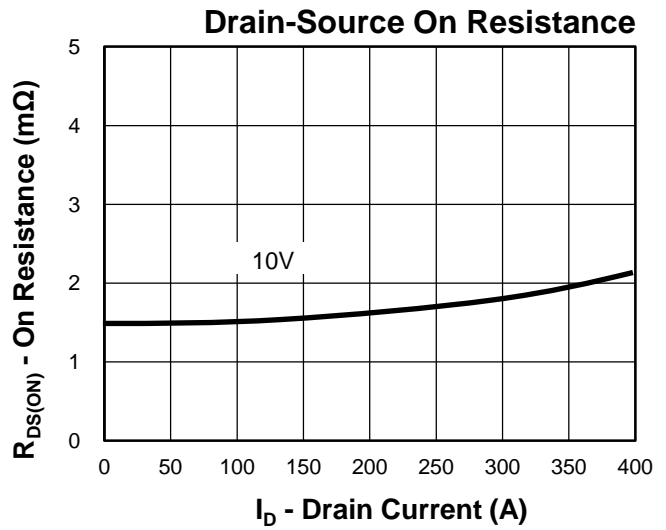
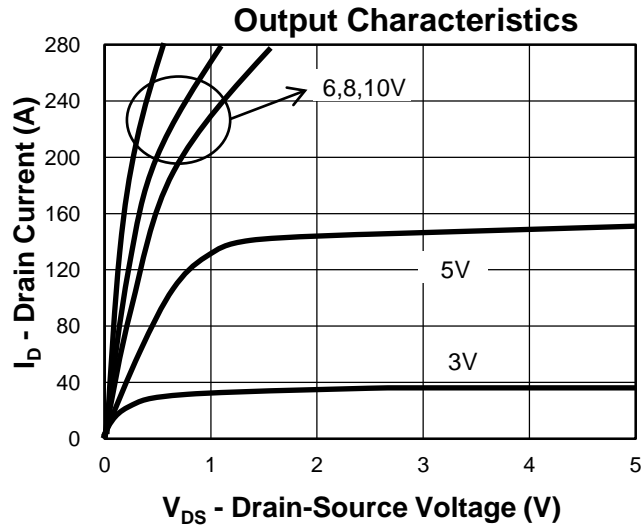

Avalanche Test Circuit and Waveforms

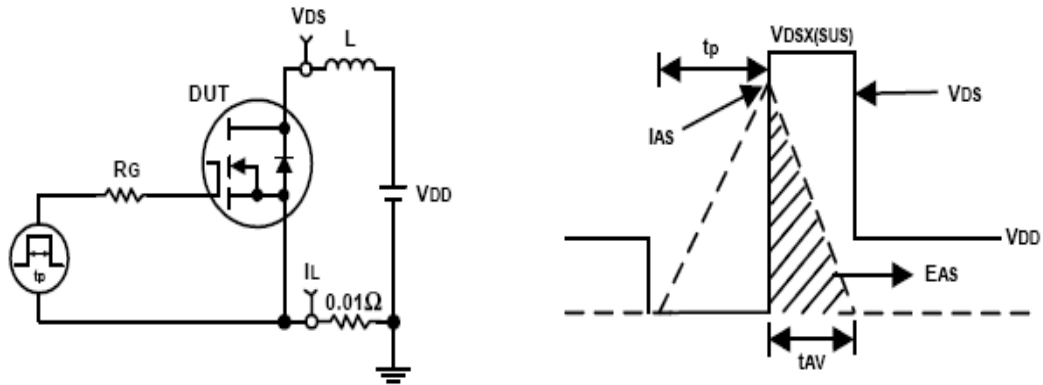

Switching Time Test Circuit and Waveforms

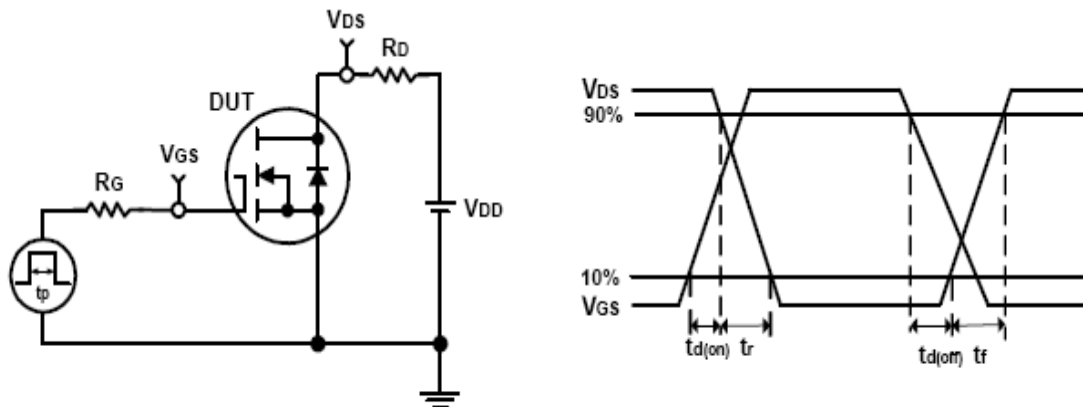

Package Information

TO247

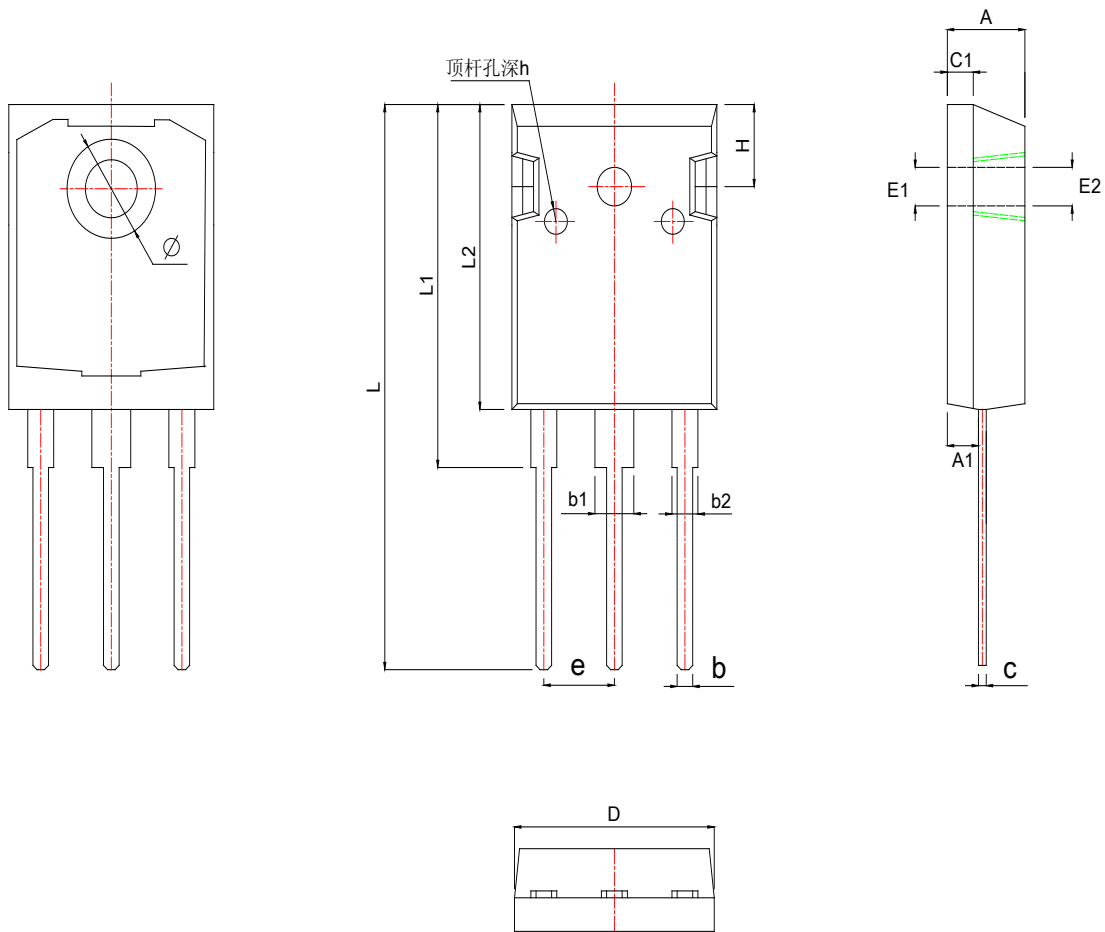

SYMBOL	MM			INCH		
	MIN	NOM	MAX	MIN	NOM	MAX
A	4.850	5.000	5.150	0.191	0.197	0.203
A1	2.200	2.400	2.600	0.087	0.094	0.102
b	1.000	1.200	1.400	0.039	0.047	0.055
b1	2.800	3.000	3.200	0.110	0.118	0.126
b2	1.800	2.000	2.200	0.071	0.079	0.087
c	0.500	0.600	0.700	0.020	0.024	0.028
c1	1.900	2.000	2.100	0.075	0.079	0.083
D	15.450	15.600	15.750	0.608	0.614	0.620
E1	3.500REF			0.138REF		
E2	3.600REF			0.142REF		
L	40.900	41.100	41.300	1.610	1.618	1.626
L1	24.800	24.950	25.100	0.976	0.982	0.988
L2	20.300	20.450	20.600	0.799	0.805	0.811
Φ	7.10	7.20	7.30	0.280	0.283	0.287
e	5.450TYP			0.215TYP		
H	5.980REF			0.235REF		
h	0.000	0.150	0.300	0.000	0.006	0.012

Customer Service**Worldwide Sales and Service:**

Sales@ruichips.com

Technical Support:

Technical@ruichips.com

Investor Relations Contacts:

Investor@ruichips.com

Marcom Contact:

Marcom@ruichips.com

Editorial Contact:

Editorial@ruichips.com

HR Contact:

HR@ruichips.com

Legal Contact:

Legal@ruichips.com

Shen Zhen RUICHIPS Semiconductor CO., LTDRoom 501, the 5floor An Tong Industrial Building,
NO.207 Mei Hua Road Fu Tian Area Shen Zhen City, CHINA**TEL:** (86-755) 8311-5334**FAX:** (86-755) 8311-4278**E-mail:** Sales-SZ@ruichips.com