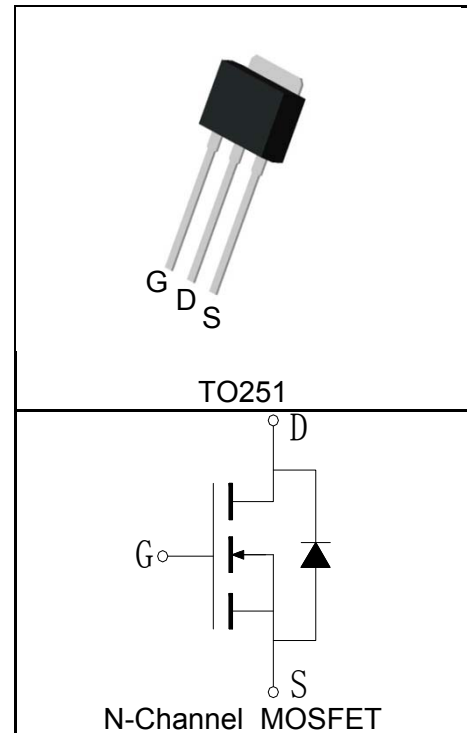

Features

- 40V/55A,
 $R_{DS(ON)} = 6.5m\Omega(Typ.)@V_{GS}=10V$
 $R_{DS(ON)} = 8m\Omega(Typ.)@V_{GS}=4.5V$
- Super High Dense Cell Design
- Ultra Low On-Resistance
- 100% avalanche tested
- Lead Free and Green Devices Available (RoHS Compliant)

Pin Description

Applications

- Power Management.
- Switch Applications.
- Load switch

Absolute Maximum Ratings

Symbol	Parameter	Rating	Unit
Common Ratings ($T_C=25^\circ C$ Unless Otherwise Noted)			
V_{DSS}	Drain-Source Voltage	40	V
V_{GSS}	Gate-Source Voltage	± 20	
T_J	Maximum Junction Temperature	175	$^\circ C$
T_{STG}	Storage Temperature Range	-55 to 175	$^\circ C$
I_S	Diode Continuous Forward Current	$T_C=25^\circ C$ 55	A
Mounted on Large Heat Sink			
$I_{DP}^{①}$	300 μs Pulse Drain Current Tested	$T_C=25^\circ C$ 200	A
$I_D^{②}$	Continuous Drain Current($V_{GS}=10V$)	$T_C=25^\circ C$ 55	A
		$T_C=100^\circ C$ 37	
P_D	Maximum Power Dissipation	$T_C=25^\circ C$ 52	W
		$T_C=100^\circ C$ 26	
$R_{\theta JC}$	Thermal Resistance-Junction to Case	2.92	$^\circ C/W$
$R_{\theta JA}$	Thermal Resistance-Junction to Ambient	100	$^\circ C/W$
Drain-Source Avalanche Ratings			
$E_{AS}^{③}$	Avalanche Energy, Single Pulsed	43	mJ

Electrical Characteristics ($T_C=25^\circ\text{C}$ Unless Otherwise Noted)

Symbol	Parameter	Test Condition	RUH4060K			Unit
			Min.	Typ.	Max.	
Static Characteristics						
BV_{DSS}	Drain-Source Breakdown Voltage	$V_{GS}=0V, I_{DS}=250\mu A$	40			V
I_{DSS}	Zero Gate Voltage Drain Current	$V_{DS}=40V, V_{GS}=0V$			1	μA
		$T_J=125^\circ C$			30	
$V_{GS(th)}$	Gate Threshold Voltage	$V_{DS}=V_{GS}, I_{DS}=250\mu A$	1	2	3	V
I_{GSS}	Gate Leakage Current	$V_{GS}=\pm 20V, V_{DS}=0V$			± 100	nA
$R_{DS(ON)}^{(4)}$	Drain-Source On-state Resistance	$V_{GS}=10V, I_{DS}=50A$		6.5	8	$m\Omega$
		$V_{GS}=4.5V, I_{DS}=35A$		8	11	$m\Omega$
Diode Characteristics						
$V_{SD}^{(4)}$	Diode Forward Voltage	$I_{SD}=50A, V_{GS}=0V$			1.2	V
t_{rr}	Reverse Recovery Time	$I_{SD}=50A, di_{SD}/dt=100A/\mu s$		9		ns
Q_{rr}	Reverse Recovery Charge			15		nC
Dynamic Characteristics ⁽⁵⁾						
R_G	Gate Resistance	$V_{GS}=0V, V_{DS}=0V, F=1MHz$		0.8		Ω
C_{iss}	Input Capacitance	$V_{GS}=0V,$ $V_{DS}=30V,$ Frequency=1.0MHz		1740		pF
C_{oss}	Output Capacitance			562		
C_{rss}	Reverse Transfer Capacitance			41		
$t_{d(ON)}$	Turn-on Delay Time	$V_{DD}=30V, I_{DS}=50A,$ $V_{GEN}=10V, R_G=4.7\Omega$		4.5		ns
t_r	Turn-on Rise Time			24		
$t_{d(OFF)}$	Turn-off Delay Time			35		
t_f	Turn-off Fall Time			12		
Gate Charge Characteristics ⁽⁵⁾						
Q_g	Total Gate Charge	$V_{DS}=48V, V_{GS}=10V,$ $I_{DS}=50A$		24		nC
Q_{gs}	Gate-Source Charge			3		
Q_{gd}	Gate-Drain Charge			2.5		

- Notes:
- ① Pulse width limited by safe operating area.
 - ② Calculated continuous current based on maximum allowable junction temperature.
 - ③ Limited by $T_{Jmax}, I_{AS}=13A, V_{DD}=32V, R_G=50\Omega$, Starting $T_J=25^\circ C$.
 - ④ Pulse test; Pulse width $\leq 300\mu s$, duty cycle $\leq 2\%$.
 - ⑤ Guaranteed by design, not subject to production testing.

Ordering and Marking Information

Device	Marking	Package	Packaging	Quantity	Reel Size	Tape width
RUH4060K	RUH4060K	TO251	Tube	75	-	-

Typical Characteristics

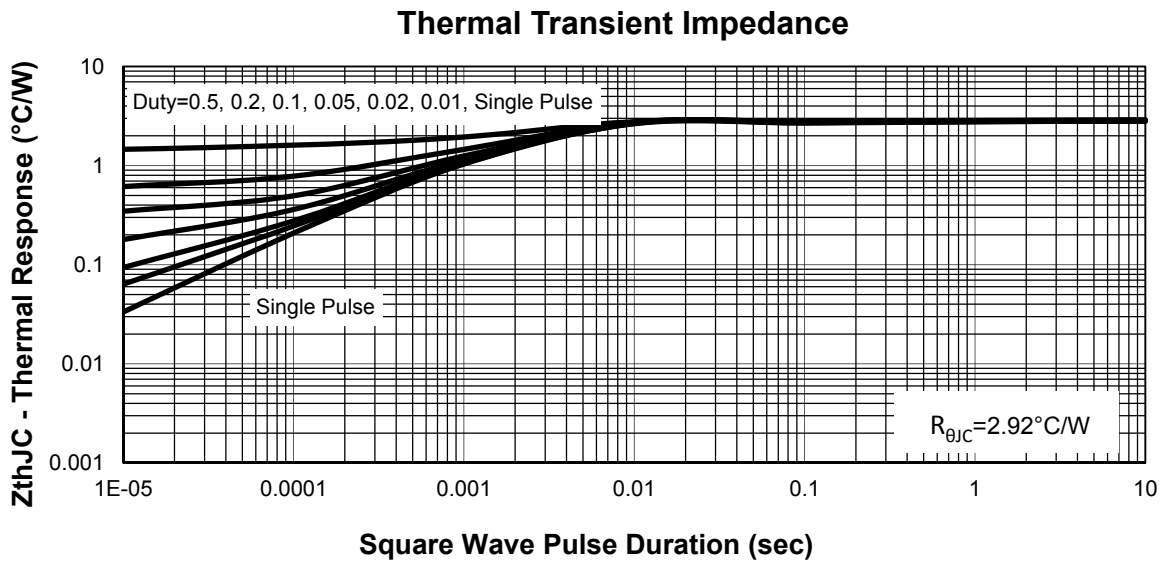
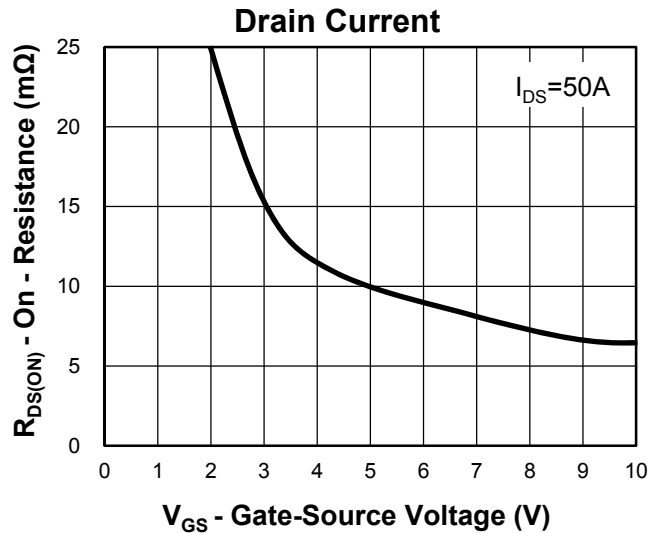
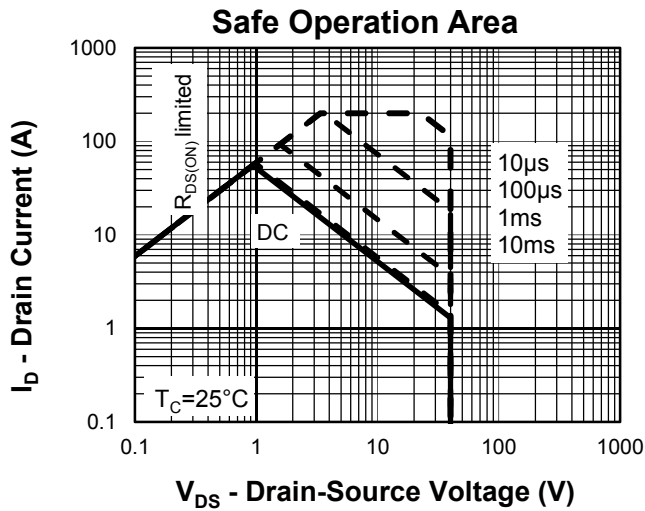
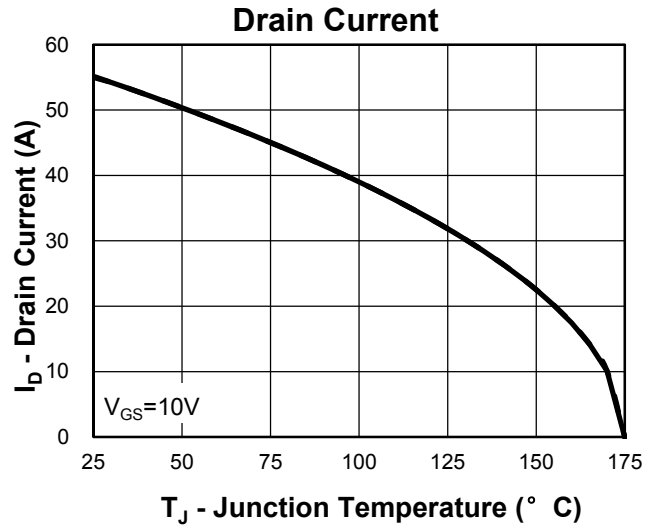
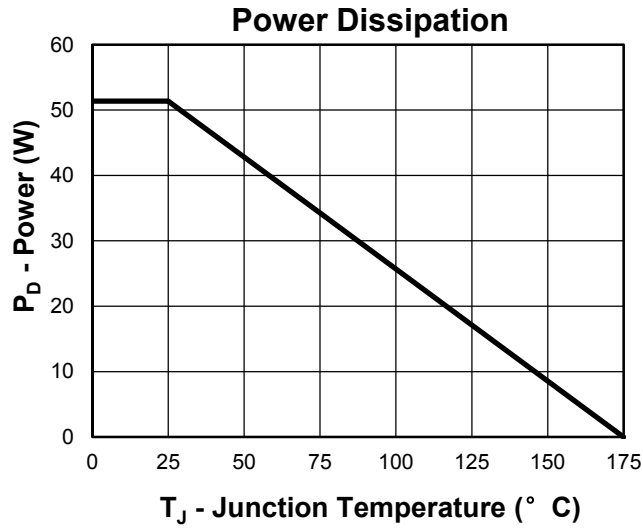

Typical Characteristics

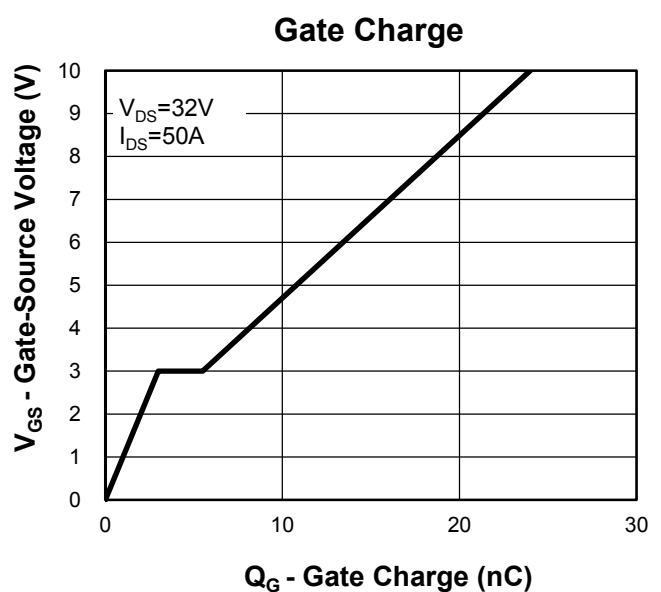
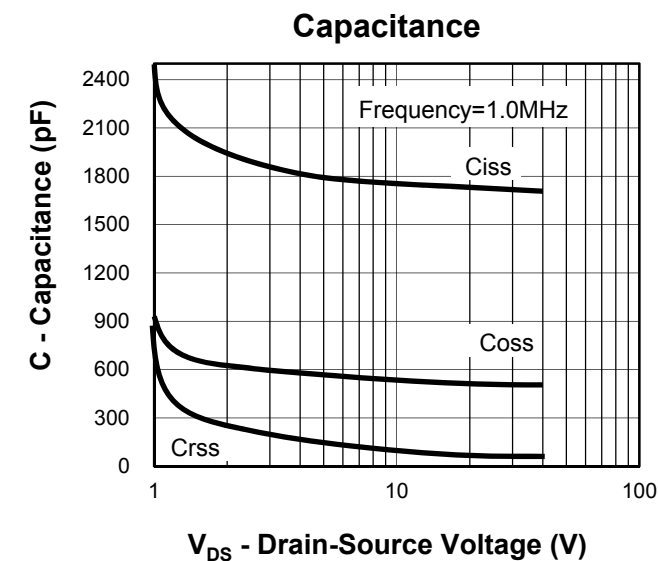
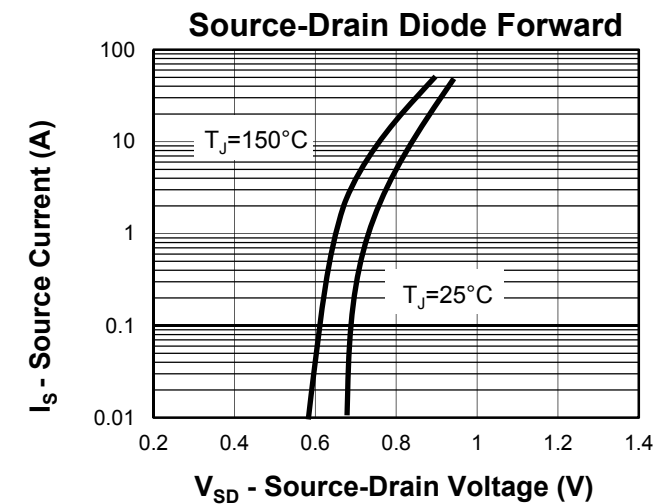
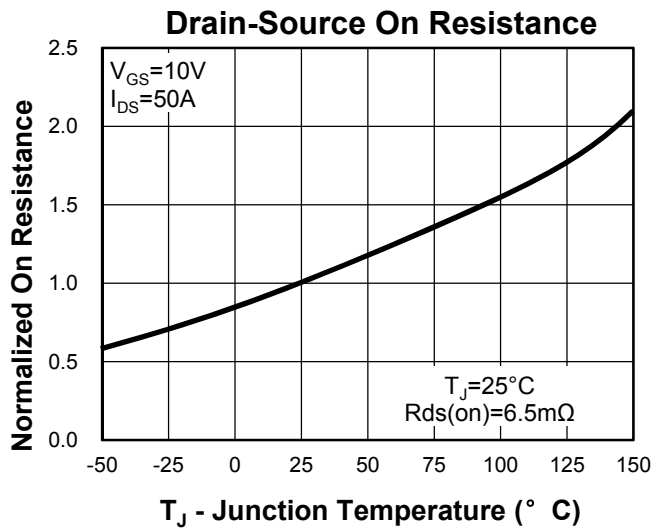
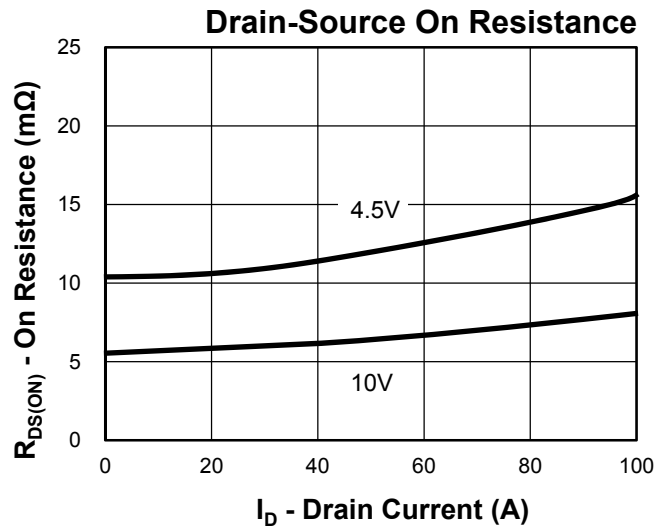
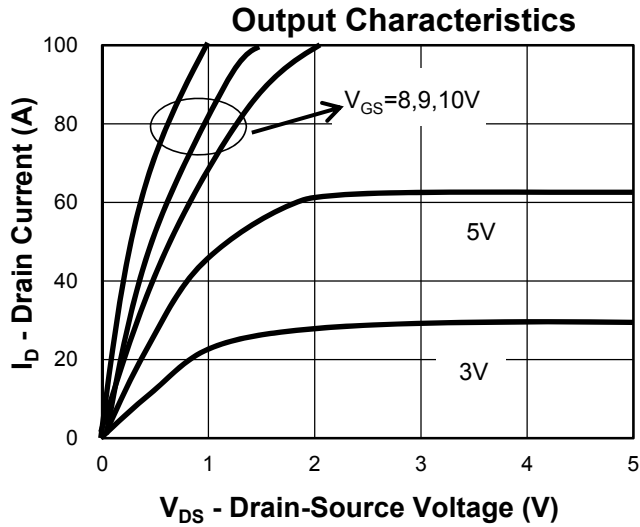

Avalanche Test Circuit and Waveforms

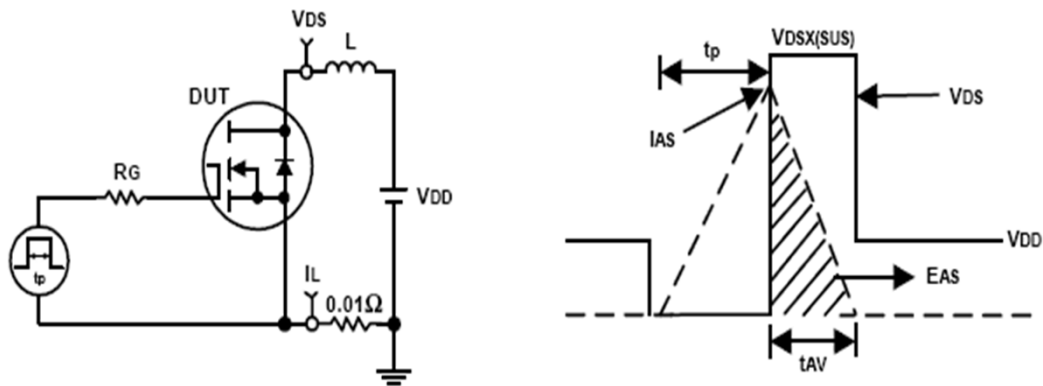

Switching Time Test Circuit and Waveforms

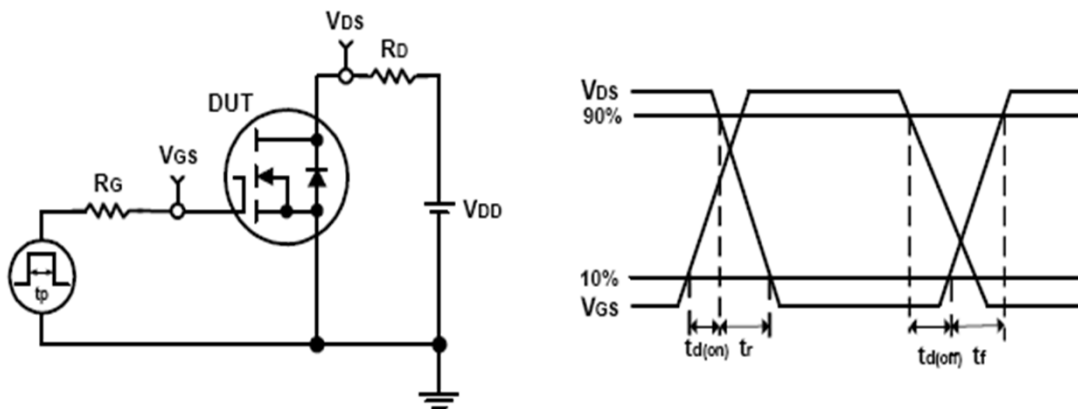

Package Information

TO251

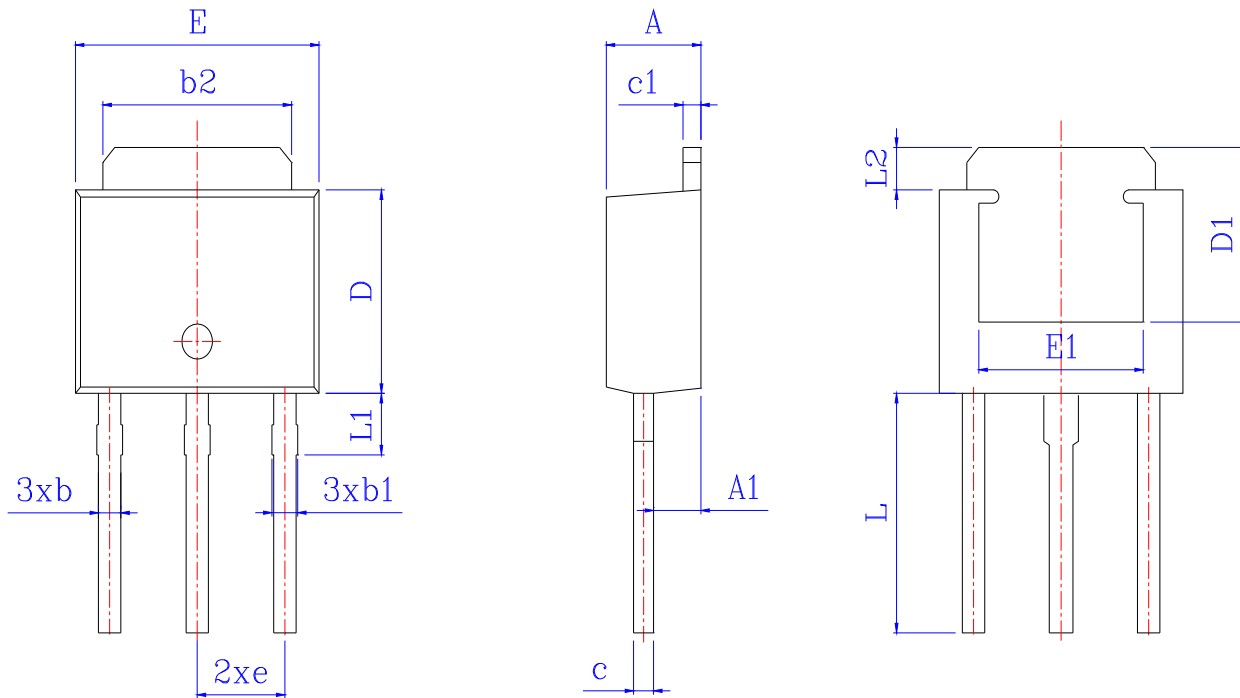

SYMBOL	MM			INCH		
	MIN	NOM	MAX	MIN	NOM	MAX
A	2.220	2.320	2.420	0.087	0.091	0.095
A1	0.890	*	1.170	0.035	*	0.046
b	0.640	*	0.850	0.025	*	0.033
b1	0.760	0.860	0.960	0.030	0.034	0.038
b2	5.200	5.300	5.400	0.205	0.209	0.213
c	0.460	0.520	0.580	0.018	0.020	0.023
c1	0.450	0.505	0.560	0.018	0.020	0.022
D	5.950	6.100	6.250	0.234	0.240	0.246
D1	4.200	4.350	4.500	0.165	0.171	0.177
E	6.400	6.550	6.700	0.252	0.258	0.264
E1	4.700	*	4.920	0.185	*	0.194
e	2.280 REF			0.090 REF		
L	8.900	*	9.600	0.350	*	0.378
L1	1.900	2.095	2.290	0.075	0.082	0.090
L2	0.900	*	1.250	0.035	*	0.049

Customer Service**Worldwide Sales and Service:**

Sales@ruichips.com

Technical Support:

Technical@ruichips.com

Investor Relations Contacts:

Investor@ruichips.com

Marcom Contact:

Marcom@ruichips.com

Editorial Contact:

Editorial@ruichips.com

HR Contact:

HR@ruichips.com

Legal Contact:

Legal@ruichips.com

Shen Zhen RUICHIPS Semiconductor CO., LTD

4th Floor, Block 8, Changyuan New Material Port, Keyuan Middle Road, Science & Industry Park,
Nanshan District, Shenzhen, CHINA

TEL: (86-755) 8311-5334

FAX: (86-755) 8311-4278

E-mail: Sales-SZ@ruichips.com